

SITE DEVELOPMENT PLANS FOR: Bragg Road Development Company, LLC

Bragg Drive & S. College Rd. Wilmington, NC 28412 (Permit # _____)



Know what's below.
Call before you dig.

Approved Construction Plan
Name _____ Date _____
Planning _____
Traffic _____
Fire _____

CITY OF WILMINGTON
NORTH CAROLINA
Public Services • Engineering Division
APPROVED STORMWATER MANAGEMENT PLAN
Date: _____ Permit # _____
Signed: _____

For each open utility cut of City streets, a \$325 permit shall be required from the City prior to occupancy and/or project acceptance.

- City of Wilmington Standard Notes**
1. Prior to any clearing, grading or construction activity, tree protection fencing shall be installed around protected trees or groves of trees. No construction workers, tools, materials, or vehicles are permitted within the tree protection fencing.
 2. Any trees and/or areas designated to be protected must be properly barricaded with fencing and protected throughout construction to insure that no clearing, grading or staging of materials will occur in these areas.
 3. No equipment is allowed on site until all tree protection fencing and silt fencing is installed and approved. Protective fencing is to be maintained throughout the duration of the project, and contractors shall receive adequate instruction on tree protection methods.
 4. All pavement markings in public rights-of-way and for driveways are to be thermoplastic and meet City and/or NCDOT standards.
 5. Once streets are open to traffic, contact Traffic Engineering regarding the installation of traffic and street name signs. Proposed street names must be approved prior to installation of street name signs.
 6. Traffic control devices (including signs and pavement markings) in areas open to public traffic are to meet MUTCD (Manual on Uniform Traffic Control Devices) standards.
 7. Contact Traffic Engineering at 910-341-7888 to ensure that all traffic signal facilities and equipment are shown on the plan.
 8. Call Traffic Engineering at 910-341-7888 forty-eight (48) hours prior to any excavation in the right-of-way.
 9. Traffic Engineering must approve of pavement marking prior to actual striping.
 10. All parking stall markings and lane arrows within the parking areas shall be white.
 11. All traffic control signs and markings off the right-of-way are to be maintained by the property owner.
 12. Stop signs and street signs to remain in place during construction.
 13. Tactile warning mats will be installed on all wheelchair ramps.
 14. A utility cut permit is required for each open cut of a city street.
 15. Any broken or missing sidewalk panels will be replaced.
 16. Contact Karen Dixon at 910-341-7888 to discuss street lighting options.
 17. Water and sewer service shall meet Cape Fear Public Utility Authority (CFPUA) details and specifications.
 18. Project shall comply with CFPUA Cross Connection Control requirements. Water meter(s) cannot be released until all requirements are met and the State has given their final approval. Call 910-343-3910 for information.
 19. If the contractor desires CFPUA water for construction, he shall apply in advance for this service and must provide a reduced pressure zone (RPZ) backflow prevention device on the developer's side of the water meter box.
 20. Any irrigation system supplied by CFPUA water shall comply with the CFPUA Cross Connection Control regulations. Call 919-343-3910 for information.
 21. Any irrigation system shall be equipped with a rain and freezer sensor.
 22. Any backflow prevention devices required by the CFPUA will need to be on the list of approved devices by USCFCCHR or ASSE.
 23. Contractor to field verify existing water and sewer service locations, sizes and materials prior to construction. Engineer to be notified of any conflicts.
 24. Contractor shall maintain all-weather access for emergency vehicles at all times during construction.
 25. Underground fire line(s) must be permitted and inspected by the Wilmington Fire Department from the public right-of-way to the building. Contact the Wilmington Fire Department Division of Fire and Life Safety at 910-341-0696.
 26. No obstructions are permitted in the space between thirty (30) inches and ten (10) feet above the ground within the triangular sight distance.
 27. Contact the North Carolina One Call Center at 1-800-632-4949 prior to doing any digging, clearing, or grading.

Project Number: 2014-090
DWG Name: 2014-090 Details.dwg
Drawing Scale: as noted
Date of Project: 10-21-2014
Engineer of Record:
Jason Henderson, P.E.
South Carolina PEF 22496
Georgia PEF 63071
North Carolina PEF 031306
Alabama PEF 52054

blue WATER
civil design, PLLC
bluewatercivil.com • Greenville, SC 29601
19 Washington Park Suite 100 • info@bluewatercivil.com

Certificates of Authorization:
SC C04212 - GA PEF005865
NC P0868 - AL CA4065E

BRAGG ROAD DEV. COMPANY, LLC
Bragg Drive
Wilmington, NC

LOCATION MAP

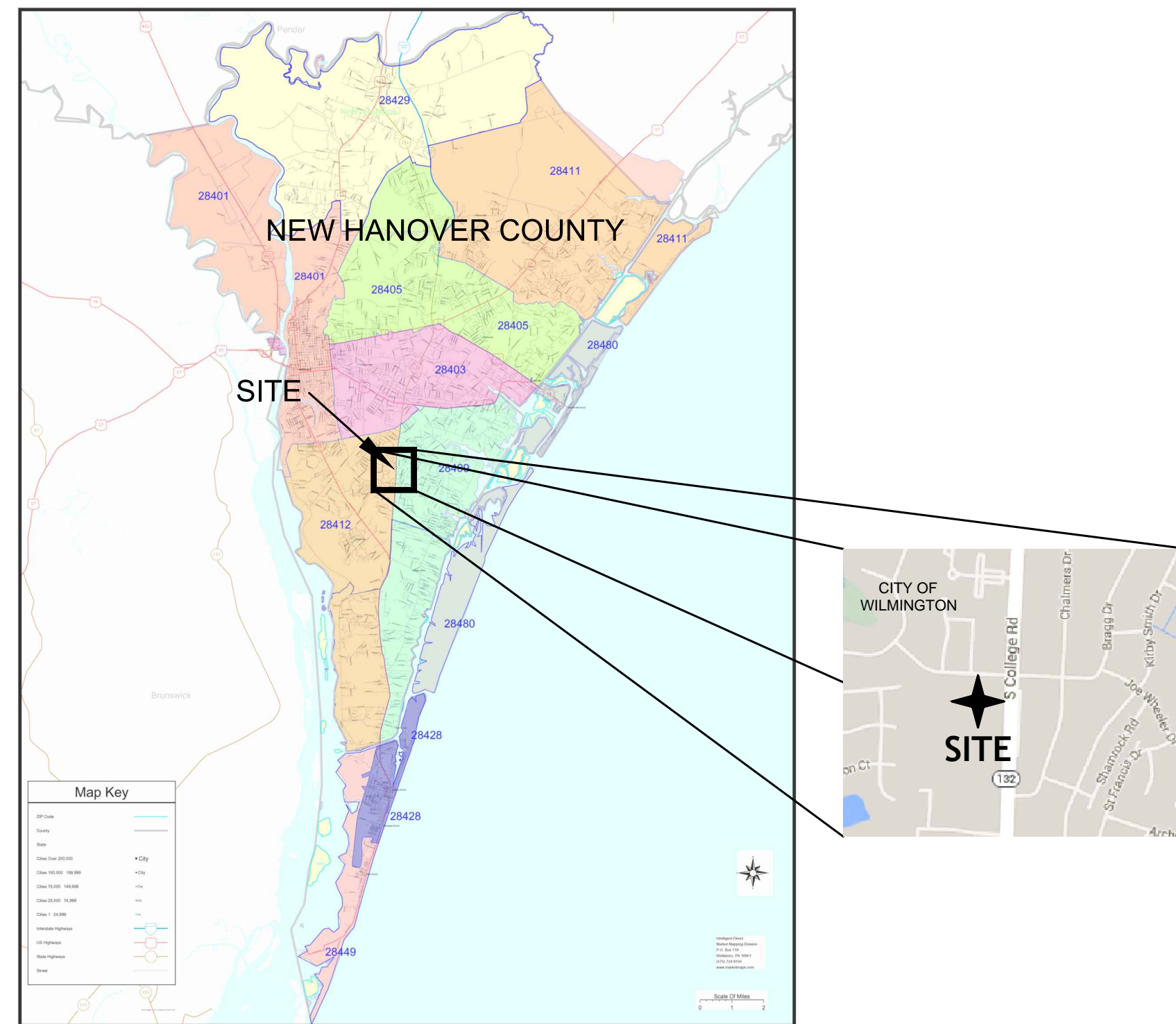

SITE CONTACTS

PLANNING / PERMIT COORDINATOR
AGENCY: City of Wilmington Planning, Development, & Trans.
ADDRESS: 305 Chestnut Street
Wilmington, NC 28402
PHONE: 910-341-3257
CONTACT: Jim Diepenbrock
EMAIL: jim.diepenbrock@wilmingtonnc.gov

LANDSCAPING
AGENCY: City of Wilmington Planning, Development, & Trans.
ADDRESS: 305 Chestnut Street
Wilmington, NC 28402
PHONE: 910-341-3257
CONTACT: Jim Diepenbrock
EMAIL: jim.diepenbrock@wilmingtonnc.gov

FIRE DISTRICT
AGENCY: City of Wilmington Fire Department
ADDRESS: 801 Market Street
Wilmington, NC 28401-4730
PHONE: 910-343-3917
CONTACT: Captain Chris Elrod
EMAIL: chris.elrod@wilmingtonnc.gov

STORMWATER
AGENCY: City of Wilmington, Engineering
ADDRESS: 102 N. Third St., PO Box 1810
Wilmington, NC 28402
PHONE: 910-341-5856
CONTACT: Rob Gordon
EMAIL: rob.gordon@wilmingtonnc.gov

TRAFFIC ENGINEERING
AGENCY: City of Wilmington/Wilmington MPO
ADDRESS: 305 Chestnut Street, 4th Floor
Wilmington, NC 28402-1810
PHONE: 910-341-4677
CONTACT: Dave Brent
EMAIL: dave.brent@wilmingtonnc.gov

WATER
AGENCY: Cape Fear Public Utility Authority
ADDRESS: 235 Government Center Drive
Wilmington, NC 28403
PHONE: 910-332-6620
CONTACT: Bernice Johnson
EMAIL: bernice.johnson@cfpua.org

SEWER
AGENCY: Cape Fear Public Utility Authority
ADDRESS: 235 Government Center Drive
Wilmington, NC 28403
PHONE: 910-332-6620
CONTACT: Bernice Johnson
EMAIL: bernice.johnson@cfpua.org

ELECTRIC DISTRIBUTION
AGENCY: Progress Energy
ADDRESS: 404 Raleigh Street
Wilmington, NC 28412
PHONE:
CONTACT:
EMAIL:

N.C.D.O.T.
AGENCY: NC Dept. of Transportation
ADDRESS: 300 Division Dr.
Wilmington, NC 28401
PHONE: 910-251-2655
CONTACT: Anthony Law
EMAIL: alaw@ncdot.gov

SHEET INDEX

DESCRIPTION	DWG. NO.
CIVIL TITLE SHEET	C001
SURVEY	SURVEY
DEMOLITION PLAN	C002
SITE PLAN	C101
SITE INVENTORY PLAN	C102
GRADING AND DRAINAGE PLAN	C201
SPOT ELEVATIONS PLAN	C201-A
WET POND BMP PLAN AND DETAILS	C201-B
PHASE I EROSION CONTROL PLAN, PERIMETER	C202
PHASE II-A EROSION CONTROL PLAN	C203
PHASE II-B EROSION CONTROL PLAN	C204
PHASE III EROSION CONTROL PLAN	C205
UTILITY PLAN	C301
NOTES AND DETAILS	C501-C515
TREE MITIGATION PLAN	LS-0
LANDSCAPE PLAN	LS-1
LANDSCAPE PLAN	LS-2

*BOUNDARY & TOPOGRAPHIC SURVEY (BY ROBERT SESSOMS & ASSOCIATES, PLLC)

DESIGNER'S CERTIFICATION:
I hereby certify that these plans have been prepared in accordance with the latest Wilmington Standards and Specifications for Storm Water Management and Chapter 20 of the Code of Ordinances of the City of Wilmington.

Jason S. Henderson
JASON S. HENDERSON, P.E., BLUEWATER CIVIL DESIGN, PLLC - NCP# 031306 DATE 2-3-2015

OWNER'S CERTIFICATION:
I/We hereby certify that any clearing, grading, construction or development, or all of these, will be done pursuant to these plans and that the applicable Stormwater Management conditions and requirements of the City of Wilmington, the State of North Carolina and the Federal Government and its agencies are hereby made part of these plans.

DATE

DEVELOPER

COMPANY: Bragg Drive Development Company, LLC
ADDRESS: 3920 Magazine Street
New Orleans, LA 70115
PHONE: 864.271.3894
CONTACT: Gordon Kolb, Jr.
EMAIL: gordo@ghkinc.com

CIVIL ENGINEER

COMPANY: Bluewater Civil Design, PLLC
ADDRESS: 19 Washington Park - Suite 100
Greenville, SC 29601
PHONE: 864.326.4204
CONTACT: Jason S. Henderson, P.E.
EMAIL: jason@bluewatercivil.com

SURVEYOR

COMPANY: Robert Sessoms & Associates, PLLC
ADDRESS: 4033 Chandler Drive
Wilmington, NC 28412
PHONE: 910-352-8846
CONTACT: Robert Sessoms
EMAIL: rsessoms@rsslurveying.com

ARCHITECT

COMPANY: Jared Ducote Architect
ADDRESS: 600 South Barracks Street, Suite 210-6
Pensacola, FL 32502
PHONE: 850-439-1552
CONTACT: Jared Ducote
EMAIL:

Approved Construction Plan
Name _____ Date _____
Planning _____
Traffic _____
Fire _____

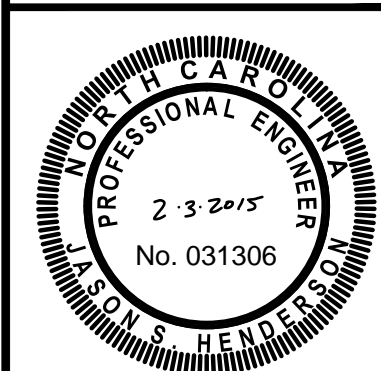

Bluewater Civil Design, PLLC
NC-P-0868

PLAN REVISION	ISSUE DATE	ISSUE COMMENT
A	2-3-2015	ISSUED FOR PERMITS

TITLE SHEET

C001

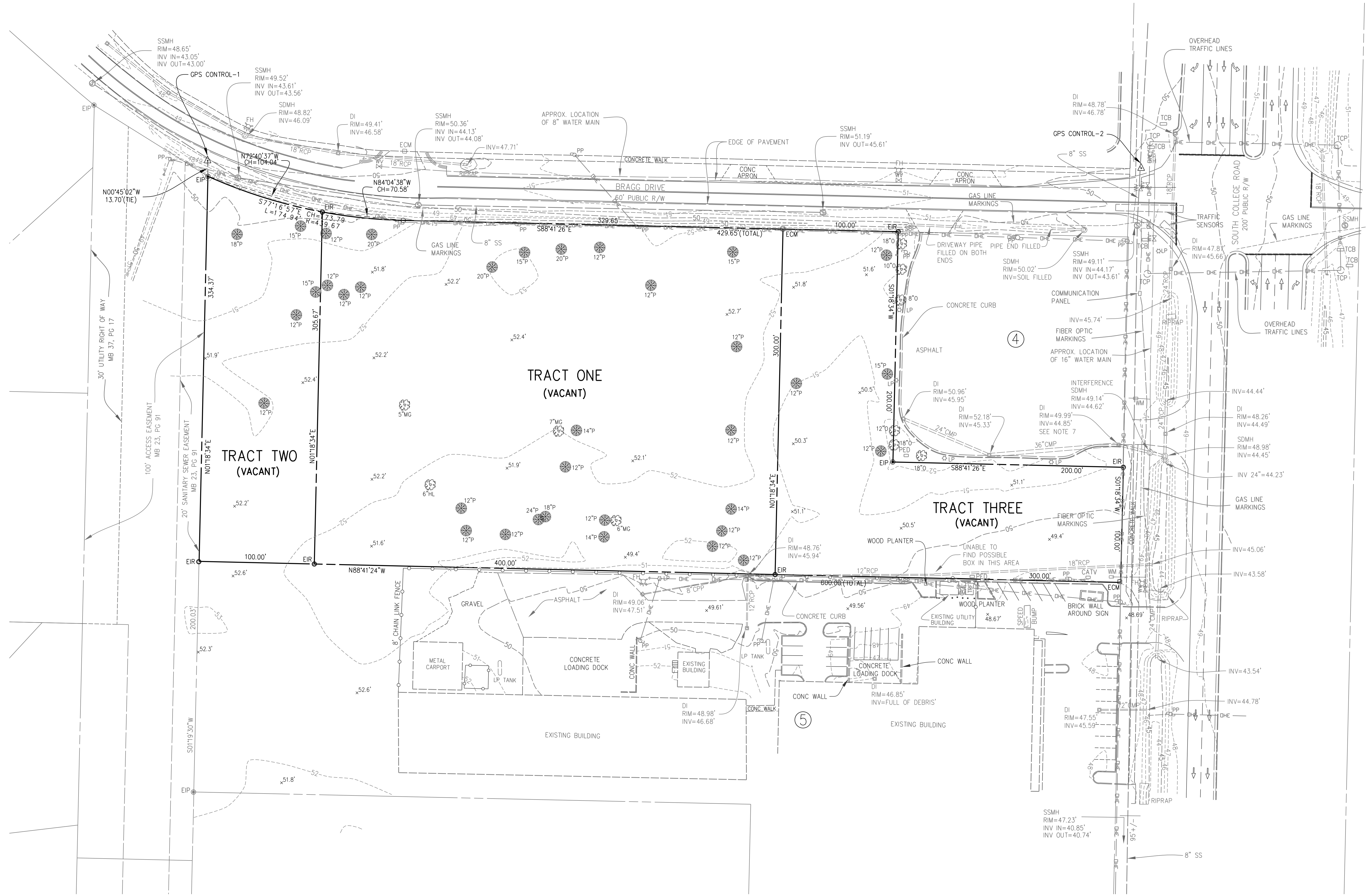

SEE SHEET 1 FOR NOTES AND CERTIFICATIONS

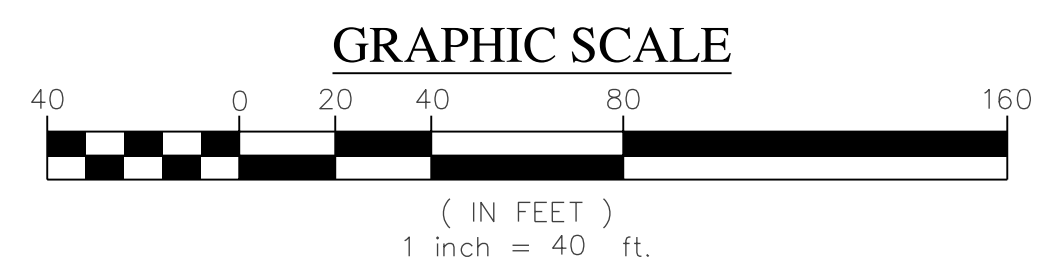

SURVEY

ROBERT G. SESSOMS
PROFESSIONAL LAND SURVEYOR
LICENSE NUMBER L-4659

SCALE	1" = 40'
DATE	09/26/2014
DRAWN BY	RGS
RSA PROJECT	#14.153

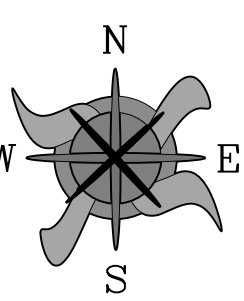

Robert Sessoms & Associates, PLLC
Professional Land Surveyors
NC LICENSE # P-0884
4055 CHANDLER DRIVE
WILMINGTON, NC 28405
PH - 910-352-8846
EMAIL - RSSESSOMS@SURVEYING.COM

Approved Construction Plan

Name _____ Date _____

Planning _____ Traffic _____ Fire _____

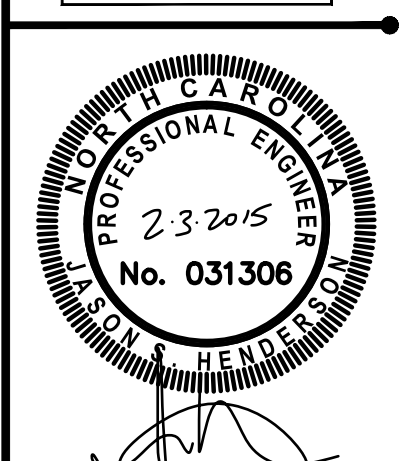

Bluewater Civil Design, PLLC
 NC-P-0868

PLAN REVISION	ISSUE DATE	ISSUE COMMENT
A	2-3-2015	ISSUED FOR PERMITS

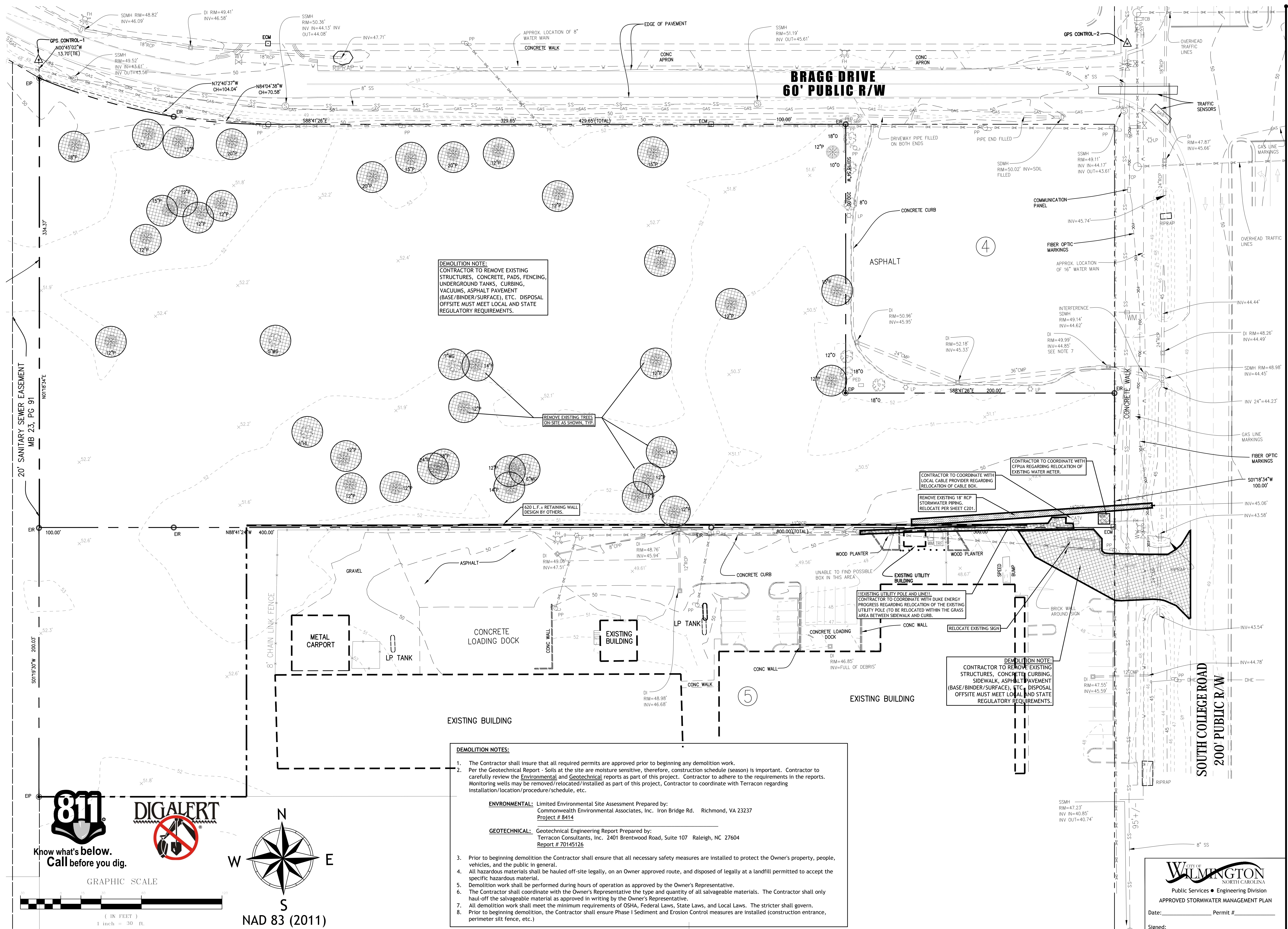

DEMOLITION NOTE:
 CONTRACTOR TO REMOVE EXISTING STRUCTURES, CONCRETE, PADS, FENCING, UNDERGROUND TANKS, CURBING, VACUUMS, ASPHALT PAVEMENT (BASE/BINDER/SURFACE), ETC. DISPOSAL OFFSITE MUST MEET LOCAL AND STATE REGULATORY REQUIREMENTS.

REMOVE EXISTING TREES ON-SITE AS SHOWN, TYP.

620 L.F. RETAINING WALL DESIGN BY OTHERS.

CONTRACTOR TO COORDINATE WITH LOCAL CABLE PROVIDER REGARDING RELOCATION OF CABLE BOX.

REMOVE EXISTING 18" RCP STORMWATER PIPING. RELOCATE PER SHEET C201.

CONTRACTOR TO COORDINATE WITH CPUSA REGARDING RELOCATION OF EXISTING WATER METER.

EXISTING UTILITY POLE AND LINE!! CONTRACTOR TO COORDINATE WITH DUKE ENERGY PROGRAM REGARDING RELOCATION OF THE EXISTING UTILITY POLE (TO BE RELOCATED WITHIN THE GRASS AREA BETWEEN SIDEWALK AND CURB).

DEMOLITION NOTE:
 CONTRACTOR TO REMOVE EXISTING STRUCTURES, CONCRETE CURBING, SIDEWALK, ASPHALT PAVEMENT (BASE/BINDER/SURFACE), ETC. DISPOSAL OFFSITE MUST MEET LOCAL AND STATE REGULATORY REQUIREMENTS.

- DEMOLITION NOTES:**
- The Contractor shall ensure that all required permits are approved prior to beginning any demolition work.
 - Per the Geotechnical Report - Soils at the site are moisture sensitive, therefore, construction schedule (season) is important. Contractor to carefully review the Environmental and Geotechnical reports as part of this project. Contractor to adhere to the requirements in the reports. Monitoring wells may be removed/relocated/installed as part of this project, Contractor to coordinate with Terracon regarding installation/location/procedure/schedule, etc.
- ENVIRONMENTAL:** Limited Environmental Site Assessment Prepared by: Commonwealth Environmental Associates, Inc. Iron Bridge Rd. Richmond, VA 23237 Project # 8414
- GEOTECHNICAL:** Geotechnical Engineering Report Prepared by: Terracon Consultants, Inc. 2401 Brentwood Road, Suite 107 Raleigh, NC 27604 Report # 70145126
- Prior to beginning demolition the Contractor shall ensure that all necessary safety measures are installed to protect the Owner's property, people, vehicles, and the public in general.
 - All hazardous materials shall be hauled off-site legally, on an Owner approved route, and disposed of legally at a landfill permitted to accept the specific hazardous material.
 - Demolition work shall be performed during hours of operation as approved by the Owner's Representative.
 - The Contractor shall coordinate with the Owner's Representative the type and quantity of all salvageable materials. The Contractor shall only haul-off the salvageable material as approved in writing by the Owner's Representative.
 - All demolition work shall meet the minimum requirements of OSHA, Federal Laws, State Laws, and Local Laws. The stricter shall govern.
 - Prior to beginning demolition, the Contractor shall ensure Phase I Sediment and Erosion Control measures are installed (construction entrance, perimeter silt fence, etc.)

811 Know what's below. Call before you dig.

DIGALERT

GRAPHIC SCALE
 (IN FEET)
 1 inch = 30 ft.

NAD 83 (2011)

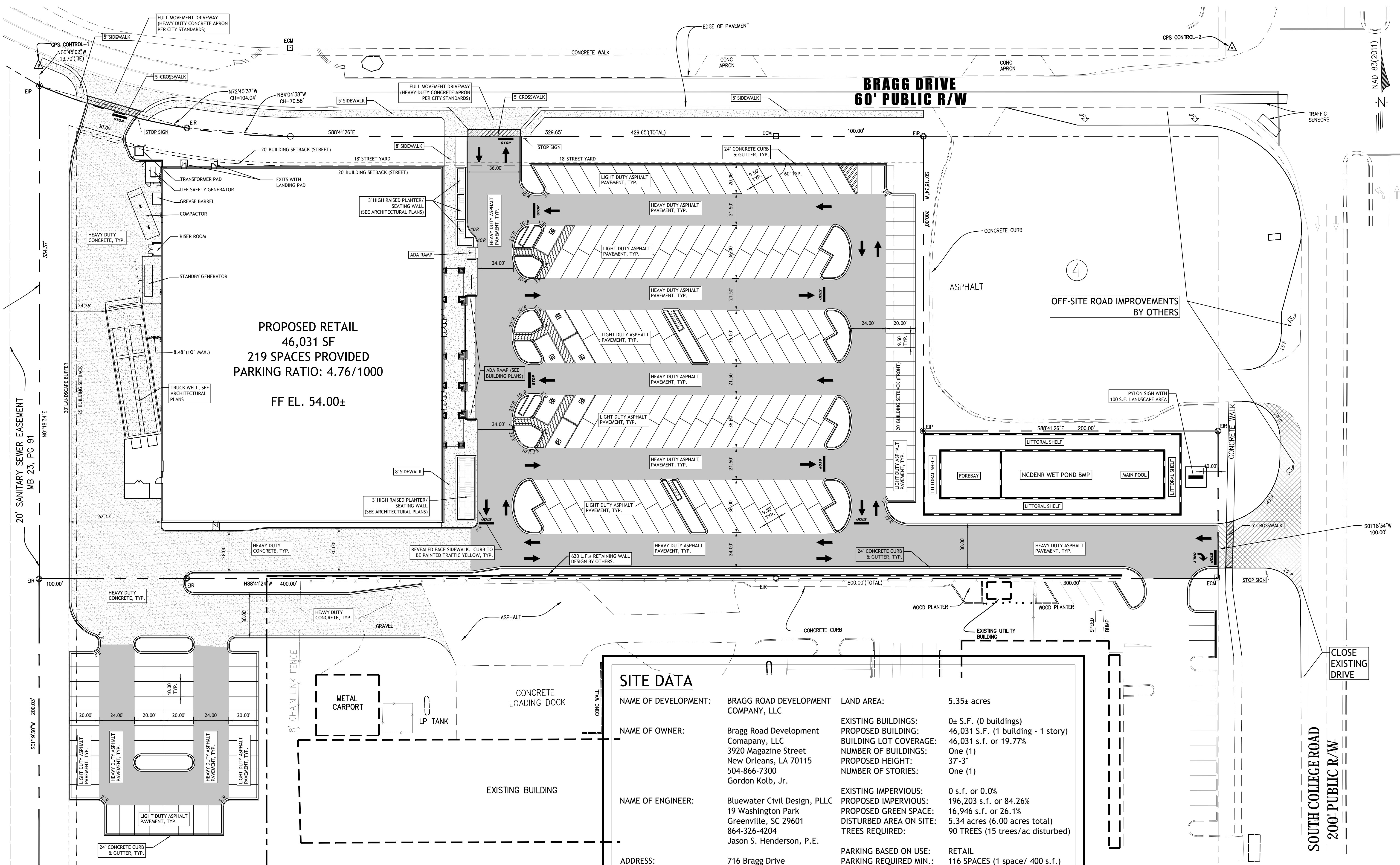

SITE DATA

NAME OF DEVELOPMENT:	BRAGG ROAD DEVELOPMENT COMPANY, LLC	LAND AREA:	5.35± acres
NAME OF OWNER:	Bragg Road Development Company, LLC 3920 Magazine Street New Orleans, LA 70115 504-866-7300 Gordon Kolb, Jr.	EXISTING BUILDINGS:	0± S.F. (0 buildings)
NAME OF ENGINEER:	Bluewater Civil Design, PLLC 19 Washington Park Greenville, SC 29601 864-326-4204 Jason S. Henderson, P.E.	PROPOSED BUILDING:	46,031 S.F. (1 building - 1 story)
ADDRESS:	716 Bragg Drive Wilmington, NC 28412	BUILDING LOT COVERAGE:	46,031 s.f. or 19.77%
PID:	R06600-001-005-000 R06610-006-002-000 R06600-001-019-000 P.O. R06610-006-014-000	NUMBER OF BUILDINGS:	One (1)
ZONING:	CB Community Business	PROPOSED HEIGHT:	37'-3"
SETBACKS REQ'D:	20' front- 20' corner side - 10' rear - 0' interior side	NUMBER OF STORIES:	One (1)
SETBACKS PROP'D:	309' front- 20' corner side - 82' rear - 37' interior side	EXISTING IMPERVIOUS:	0 s.f. or 0.0%
		PROPOSED IMPERVIOUS:	196,203 s.f. or 84.26%
		PROPOSED GREEN SPACE:	16,946 s.f. or 26.1%
		DISTURBED AREA ON SITE:	5.34 acres (6.00 acres total)
		TREES REQUIRED:	90 TREES (15 trees/ac disturbed)
		PARKING BASED ON USE:	RETAIL
		PARKING REQUIRED MIN.:	116 SPACES (1 space/ 400 s.f.)
		PARKING REQUIRED MAX.:	232 SPACES (1 space/ 200 s.f.)
		PROPOSED PARKING:	220 SPACES
		HANDICAP PARKING REQ'D:	7 SPACES
		HANDICAP PARKING PROVD:	7 SPACES
		BICYCLE PARKING REQ'D:	7 SPACES
		BICYCLE PARKING PROVD:	7 SPACES
		CAMA Land Use:	Urban
		EXISTING FLOW NEEDS:	0 GPD (WATER & SEWER)
		PROPOSED FLOW NEEDS:	5,984 GPD (WATER & SEWER)

CURBING NOTE:
ALL CURBING ON PRIVATE PROPERTY SHALL BE 24" CONCRETE CURB AND GUTTER PER CITY OF WILMINGTON STANDARD DETAIL SD 7-01.

ADA RAMP NOTE:
TACTILE WARNING MATS ARE TO BE INSTALLED ON ALL ADA RAMPS.

CITY OF WILMINGTON
NORTH CAROLINA
Public Services • Engineering Division
APPROVED STORMWATER MANAGEMENT PLAN
Date: _____ Permit # _____
Signed: _____

ARCHITECTURAL NOTE:
CONTRACTOR TO REFER TO ARCHITECTURAL PLANS FOR EXACT DIMENSIONS OF BUILDING, SIDEWALKS ADJACENT TO BUILDING, COLUMN LOCATIONS, DOOR/ENTRY LOCATIONS, BOLLARDS, COMPACTORS, ELECTRICAL/MECHANICAL EQUIPMENT, TRUCK WELL, ROOF DRAIN DOWNSPOUTS, AND ALL UTILITY CONNECTIONS.

BUILDING FOOTING NOTE:
IT IS THE CONTRACTORS RESPONSIBILITY TO COORDINATE BETWEEN THE CIVIL PLANS / ARCHITECTURAL PLANS / STRUCTURAL PLANS REGARDING THE GROUND ELEVATIONS DIRECTLY EXTERNAL OF THE BUILDING IN RELATION TO THE STRUCTURAL BUILDING FOOTINGS.

SITE LIGHTING NOTE:
SEE SITE LIGHTING PLAN (E-101) FOR ALL POLE LOCATIONS, FIXTURE AND PHOTOMETRIC INFORMATION. POLE LOCATIONS ARE SHOWN ON THIS PLAN FOR INFORMATION ONLY.

SITE LANDSCAPING NOTE:
SEE LANDSCAPE PLANS FOR ALL PERMANENT VEGETATION REQUIREMENTS/INFORMATION. I.E. SOD, TREES, SHRUBS, MULCHING, ETC.

811
Know what's below.
Call before you dig.

DIGALERT

GRAPHIC SCALE
(IN FEET)
1 inch = 30 ft

NAD 83 (2011)

Project Number: 2014-090
DWG Name: 2014-090 D1.dwg
Drawing Scale: AS NOTED
Date of Project: 10-21-2014
Engineer of Record:
Jason Henderson, P.E.
South Carolina PE# 21466
Georgia PE# 03571
North Carolina PE# 03106
Alabama PE# 37054
Louisiana PE# 38891
Virginia PE# 60203318

bluewater
civil design, PLLC
bluewatercivil.com • info@bluewatercivil.com
19 Washington Park Suite 100 • Greenville, SC 29601

Certificates of Authorization:
SC C04212 - GA PEF005865
NC P0868 - AL CA4065E

BRAGG ROAD DEV. COMPANY, LLC
Bragg Drive
Wilmington, NC

Approved Construction Plan
Name: _____
Date: _____
Planning: _____
Traffic: _____
Fire: _____

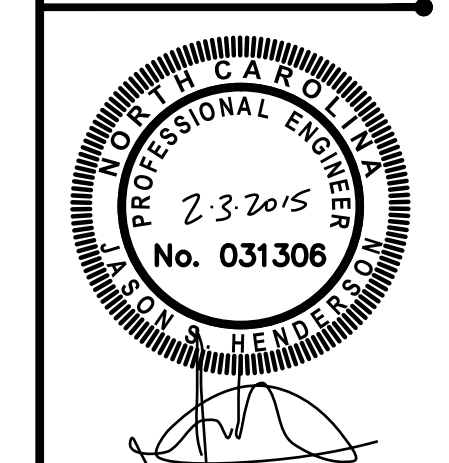

Bluewater Civil Design, PLLC
NC P-0868

PLAN REVISION	ISSUE DATE	ISSUE COMMENT
A	2-3-2015	ISSUED FOR PERMITS

SITE PLAN

C101

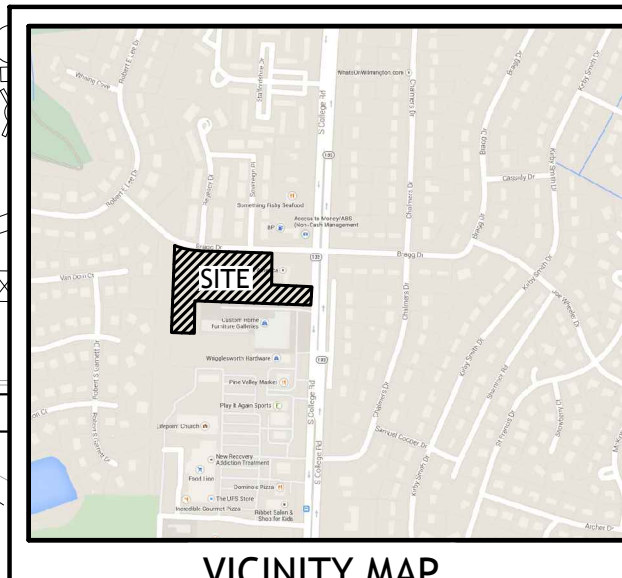
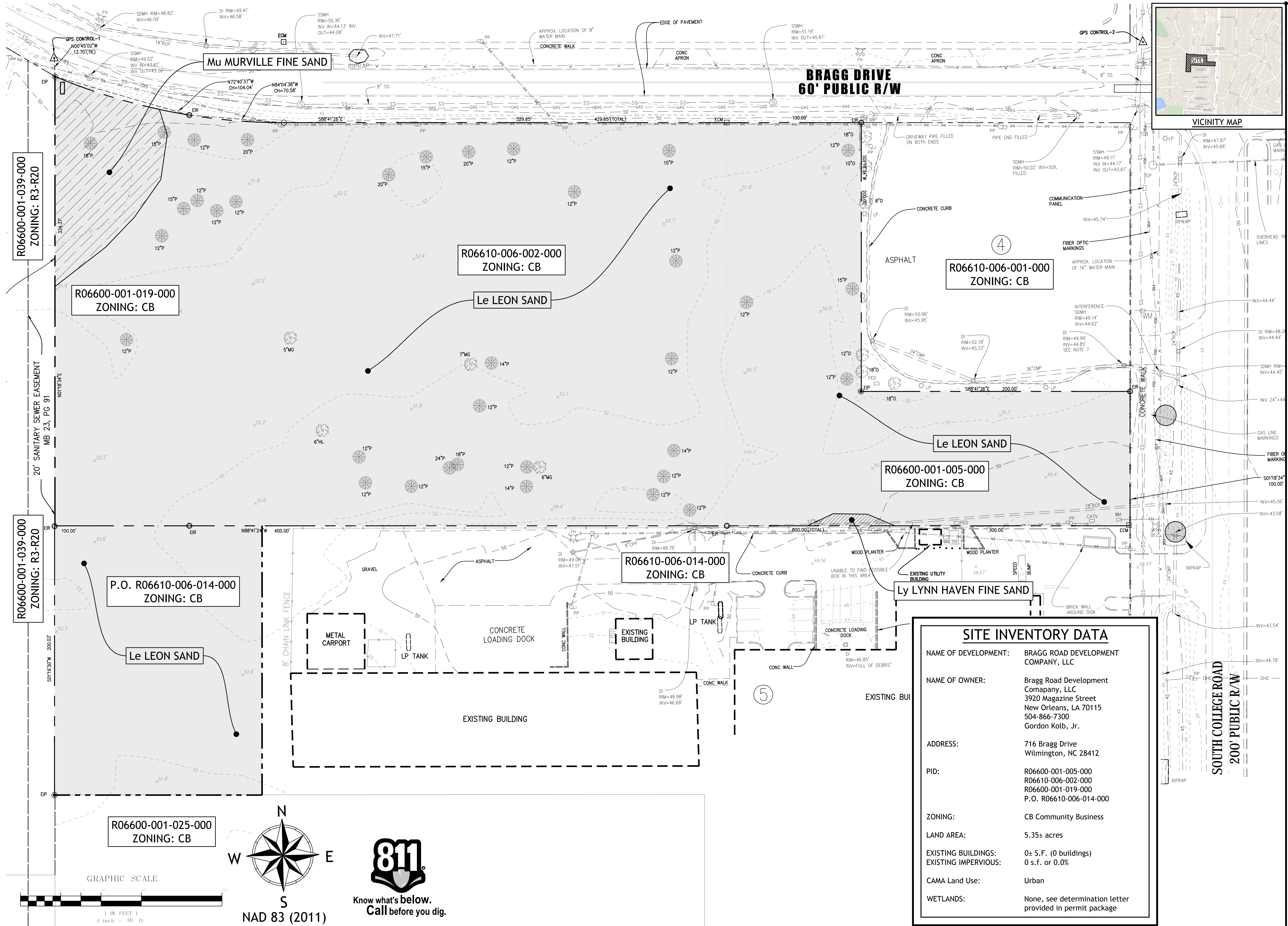

SITE INVENTORY DATA	
NAME OF DEVELOPMENT:	BRAGG ROAD DEVELOPMENT COMPANY, LLC
NAME OF OWNER:	Bragg Road Development Company, LLC 3920 Magazine Street New Orleans, LA 70115 504-866-7300 Gordon Kolb, Jr.
ADDRESS:	716 Bragg Drive Wilmington, NC 28412
PID:	R06600-001-005-000 R06610-006-002-000 R06600-001-019-000 P.O. R06610-006-014-000
ZONING:	CB Community Business
LAND AREA:	5.35± acres
EXISTING BUILDINGS:	0± S.F. (0 buildings)
EXISTING IMPERVIOUS:	0 s.f. or 0.0%
CAMA Land Use:	Urban
WETLANDS:	None, see determination letter provided in permit package

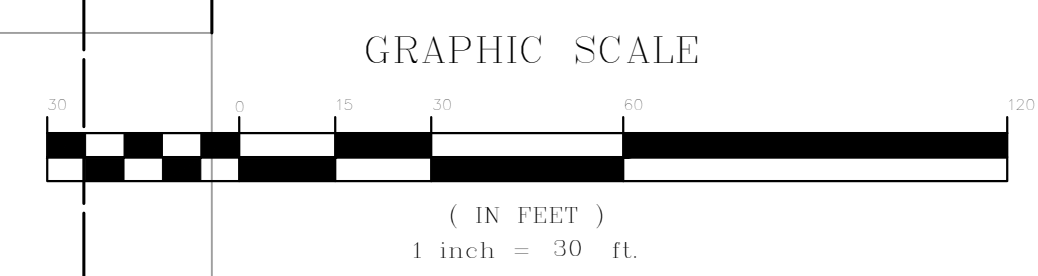
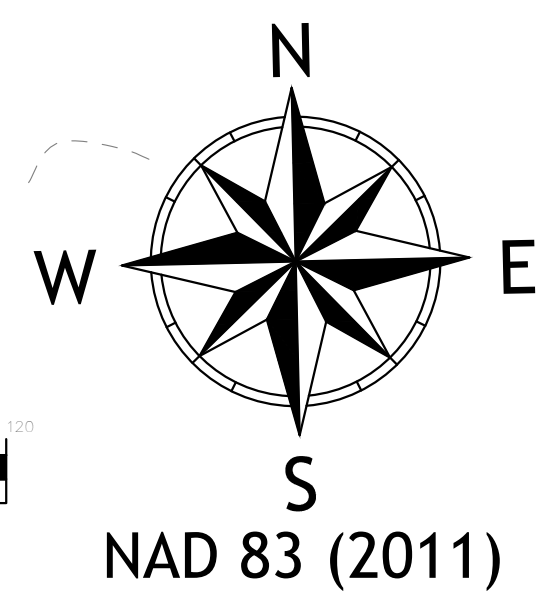

Project Number: 2014-090
 DWG Name: 2014-090 D1 - Site Inventory.dwg
 Drawing Scale: as noted
 Date of Project: 10-21-2014

Engineer of Record:
 Jason Henderson, P.E.
 South Carolina Reg. #2406
 Georgia Reg. #03511
 North Carolina Reg. #01306
 Alabama Reg. #12054
 Louisiana Reg. #8895
 Virginia Reg. #62020318

bluewater
 civil design, PLLC
 bluewatercivil.com • info@bluewatercivil.com
 19 Washington Park Suite 100 • Greenville, SC 29601

Certificates of Authorization:
 SC CD4212 - GA PE005865
 NC P0868 - AL CA4065E

BRAGG ROAD DEV. COMPANY, LLC
 Bragg Drive
 Wilmington, NC

PROFESSIONAL ENGINEER
 JASON HENDERSON
 No. 031306
 2-3-2015

Bluewater Civil Design, PLLC
 NC-P-0868

PLAN REVISION	ISSUE DATE	ISSUE COMMENT
A	2-3-2015	ISSUED FOR PERMITS

SITE INVENTORY PLAN

C101-A

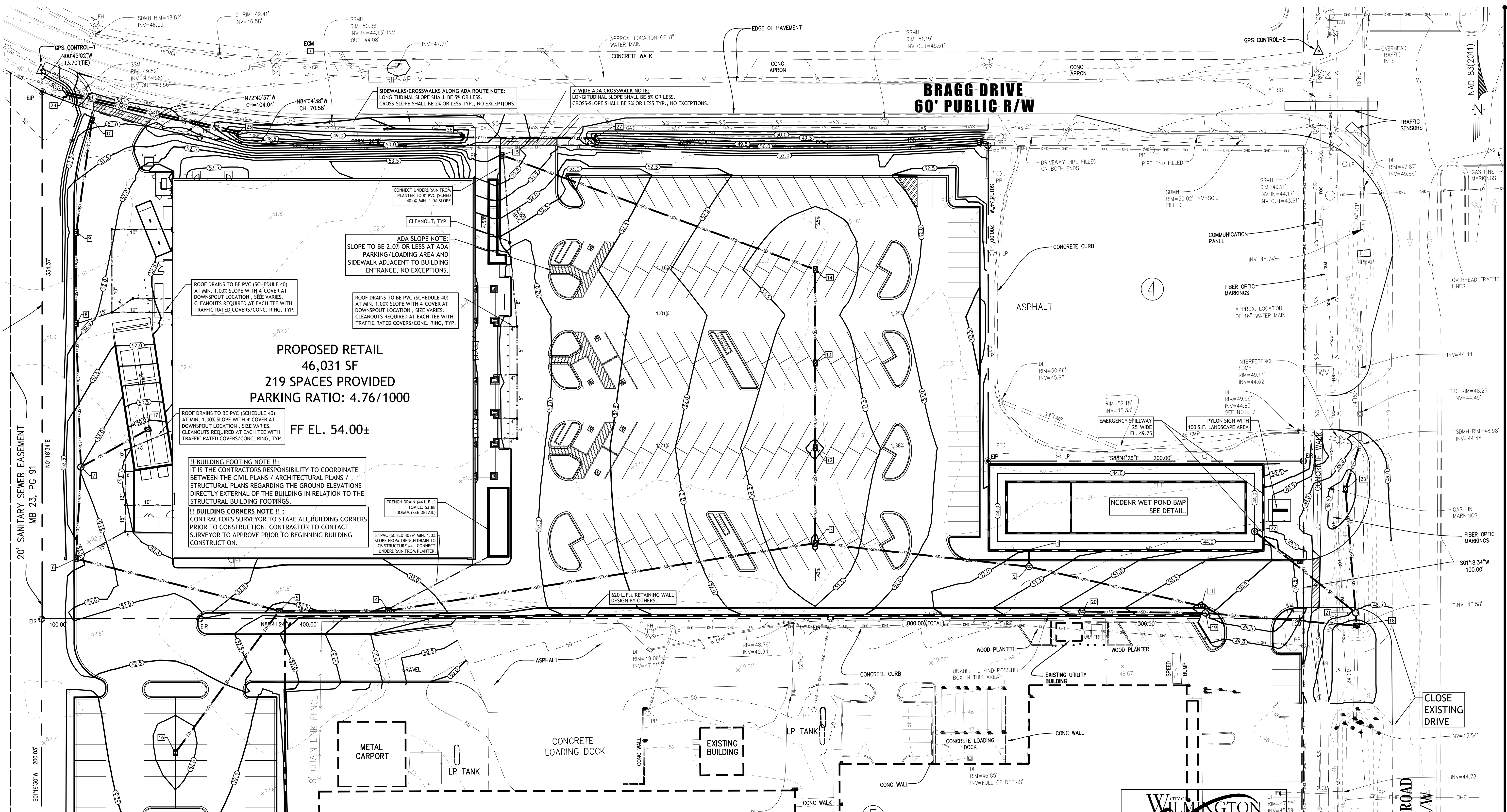

Structure ID	Structure Type	Ground (Rim/Weir) Elevation (ft)	Invert Elevation (ft)	Structure Depth (ft)	Line ID	Length (ft)	Upstream Invert Elevation (ft)	Downstream Invert Elevation (ft)	Total Drop (ft)	Slope (%)	Pipe Material	Pipe Diameter (inches)
1	END OF PIPE	...	44.00
2	Manhole	51.75	44.05	7.70	2-1	11	44.05	44.00	0.05	0.46	Class III RCP	30
3	Grate	50.94	44.60	6.34	3-2	136	44.60	44.05	0.55	0.40	Class III RCP	30
4	Hooded Grate	52.44	45.71	6.73	4-3	274	45.71	44.60	1.11	0.41	Class III RCP	24
5	Hooded Grate	52.36	45.99	6.37	5-4	69	45.99	45.71	0.28	0.40	Class III RCP	24
6	Hooded Grate	52.35	46.52	5.83	6-5	133	46.52	45.99	0.53	0.40	Class III RCP	24
7	Manhole	52.96	46.76	6.20	7-6	58	46.76	46.52	0.24	0.41	Class III RCP	18
8	Hooded Grate	51.84	47.13	4.71	8-7	91	47.13	46.76	0.37	0.41	Class III RCP	18
9	Hooded Grate	51.56	47.36	4.20	9-8	58	47.36	47.13	0.23	0.40	Class III RCP	18
10	Hooded Grate	50.90	47.65	3.25	10-9	72	47.65	47.36	0.29	0.40	Class III RCP	15
11	Hooded Grate	50.00	46.43	3.57	11-2	112	46.43	45.05	1.38	1.23	Class III RCP	18
12	Grate	50.93	45.65	5.28	12-3	60	45.65	45.10	0.55	0.91	Class III RCP	18
13	Grate	51.00	46.00	5.00	13-12	54	46.00	45.65	0.35	0.65	Class III RCP	18
14	Grate	51.00	46.40	4.60	14-13	59	46.40	46.00	0.40	0.67	Class III RCP	18
15	Hooded Grate	51.00	47.50	3.50	15-14	211	47.50	46.40	1.10	0.52	Class III RCP	18
16	Grate	51.70	48.20	3.50	16-5	112	48.20	45.99	2.21	1.98	Class III RCP	18
17	Grate	49.75	47.25	2.50	17-7	49	47.25	46.76	0.49	1.00	SCHED. 40 PVC	6
18	Grate	47.48	43.58	3.90
19	Manhole	50.00	44.63	5.37	19-18	96	44.63	43.58	1.05	1.09	Class III RCP	18
20	Manhole	51.37	45.48	5.89	20-19	78	45.48	44.63	0.85	1.09	Class III RCP	18
21	Manhole	48.45	43.62	4.83	21-18	8	43.62	43.58	0.04	0.49	Class III RCP	24
22	Riser	49.25	44.00	5.25	22-21	82	44.00	43.62	0.38	0.46	Class III RCP O-RING	18
23	Grate	48.00	44.22	3.78	23-21	79	44.22	43.62	0.60	0.76	Class III RCP	24
24	Headwall	48.98	44.45	4.53	EX-23	30	44.45	44.22	0.23	0.77	Class III RCP	24
25	Headwall	48.00	48.50	...	25-24	112	48.50	48.00	0.50	0.45	Class IV RCP	(2)-12
26	Headwall	48.00	49.00
27	Headwall	48.00	49.50	...	27-26	81	49.50	49.00	0.50	0.62	Class IV RCP	12

811 DIGALERT
 Know what's below. Call before you dig.
 GRAPHIC SCALE
 (IN FEET)
 1 inch = 30 ft

NAD 83 (2011)

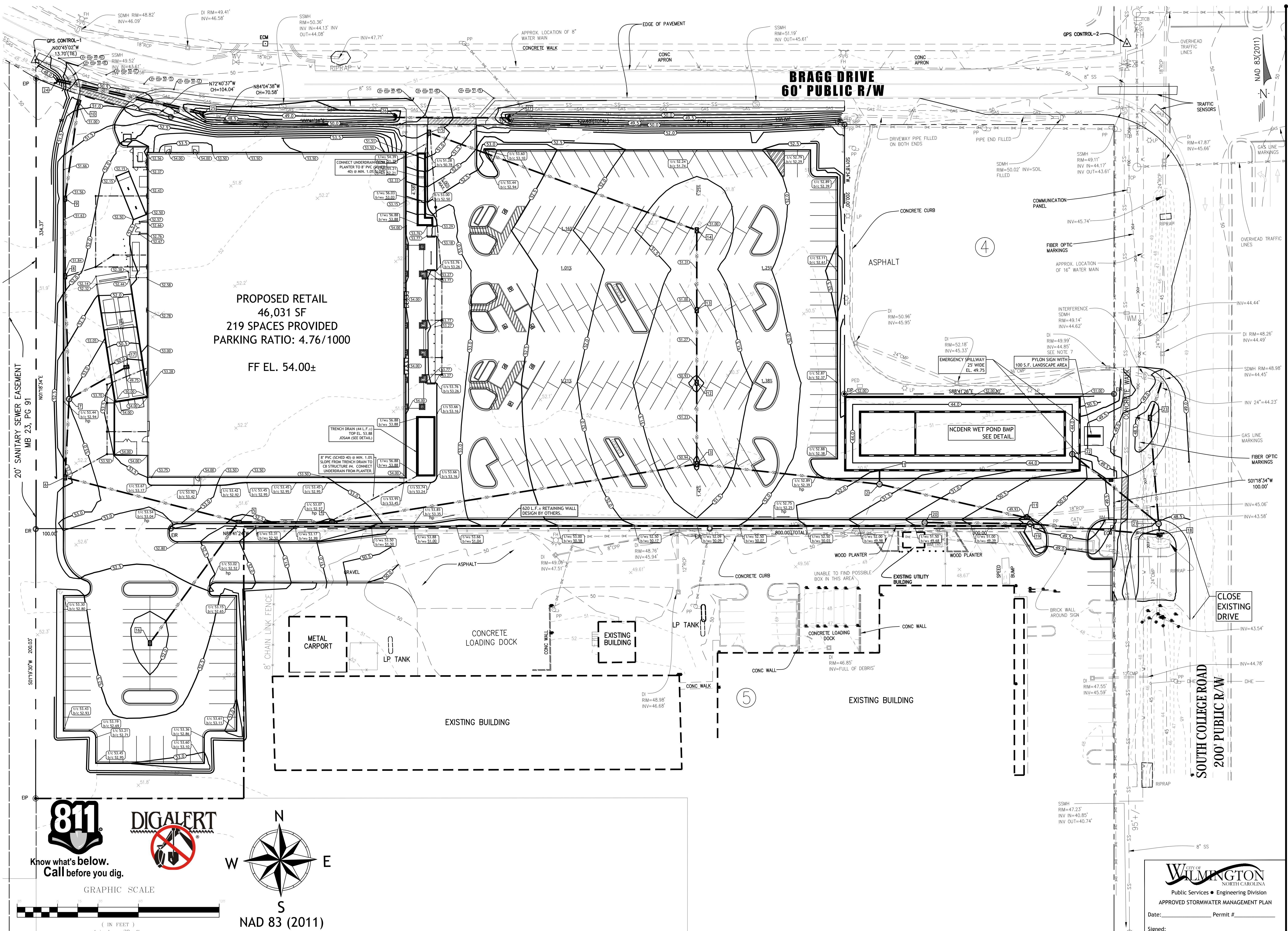

PROPOSED RETAIL
46,031 SF
219 SPACES PROVIDED
PARKING RATIO: 4.76/1000
FF EL. 54.00±

BRAGG DRIVE
60' PUBLIC R/W

SOUTH COLLEGE ROAD
200' PUBLIC R/W

20' SANITARY SEWER EASEMENT
 MB 23, PG 91

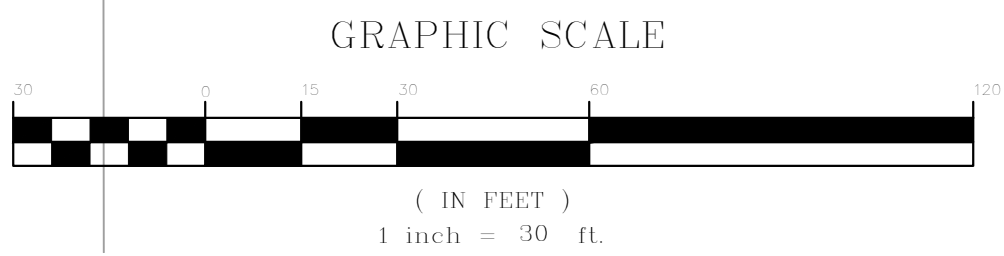
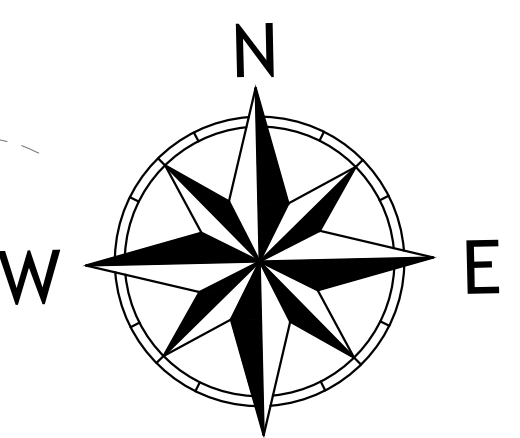

NAD 83 (2011)

WILMINGTON
 NORTH CAROLINA
 Public Services • Engineering Division
 APPROVED STORMWATER MANAGEMENT PLAN
 Date: _____ Permit # _____
 Signed: _____

Project Number: 2014-090
 DWG Name: 2014-090 D1.dwg
 Drawing Scale: AS NOTED
 Date of Project: 10-21-2014
 Engineer of Record:
 Jason Henderson, P.E.
 South Carolina PE# 21465
 Georgia PE# 03171
 North Carolina PE# 03106
 Alabama PE# 33914
 Louisiana PE# 38891
 Virginia PE# 60203118

blue WATER
 civil design
 bluewater civil design, PLLC
 19 Washington Park Suite 100 • Greenville, SC 29601
 www.bluewatercivil.com • info@bluewatercivil.com

Certificates of Authorization:
 SC C04212 - GA PEF005865
 NC P0868 - AL CA4065E

BRAGG ROAD DEV.
COMPANY, LLC
 Bragg Drive
 Wilmington, NC

Approved Construction Plan

Name	Date
Planning	
Traffic	
Fire	

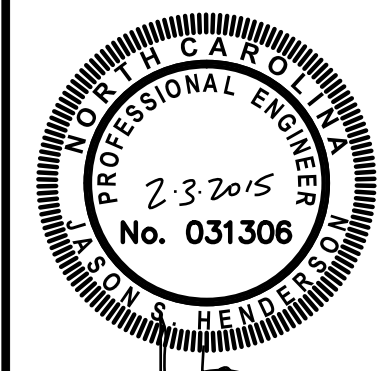

Bluewater Civil Design, PLLC
 NC-P-0868

PLAN REVISION	ISSUE DATE	ISSUE COMMENT
A	2-3-2015	ISSUED FOR PERMITS

SPOT ELEVATIONS PLAN

C201-A

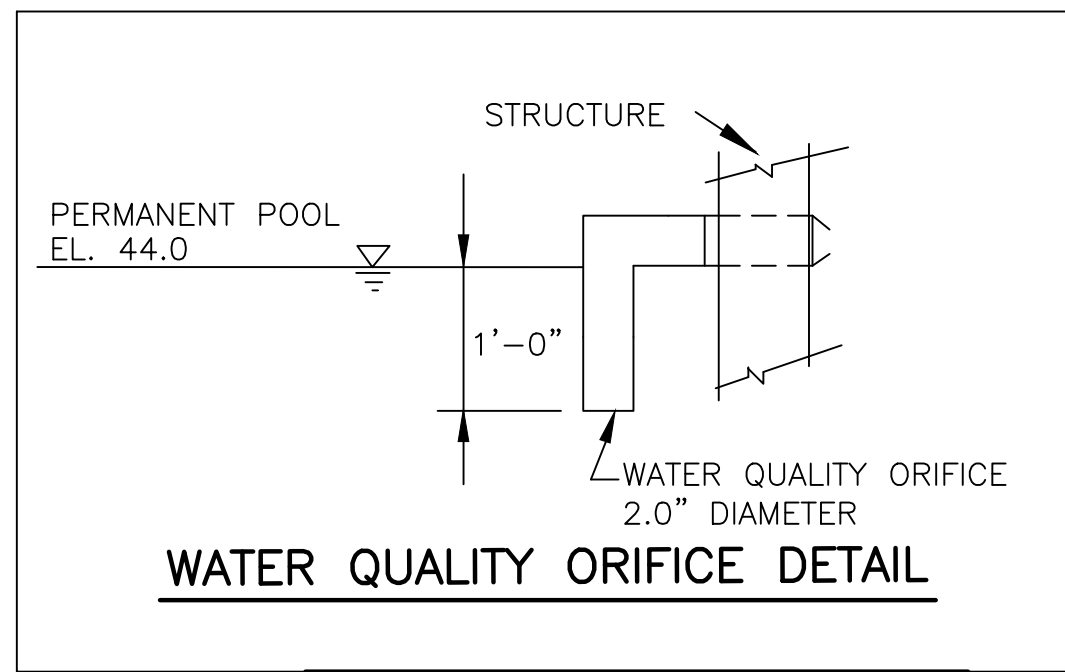

WATER QUALITY ORIFICE DETAIL

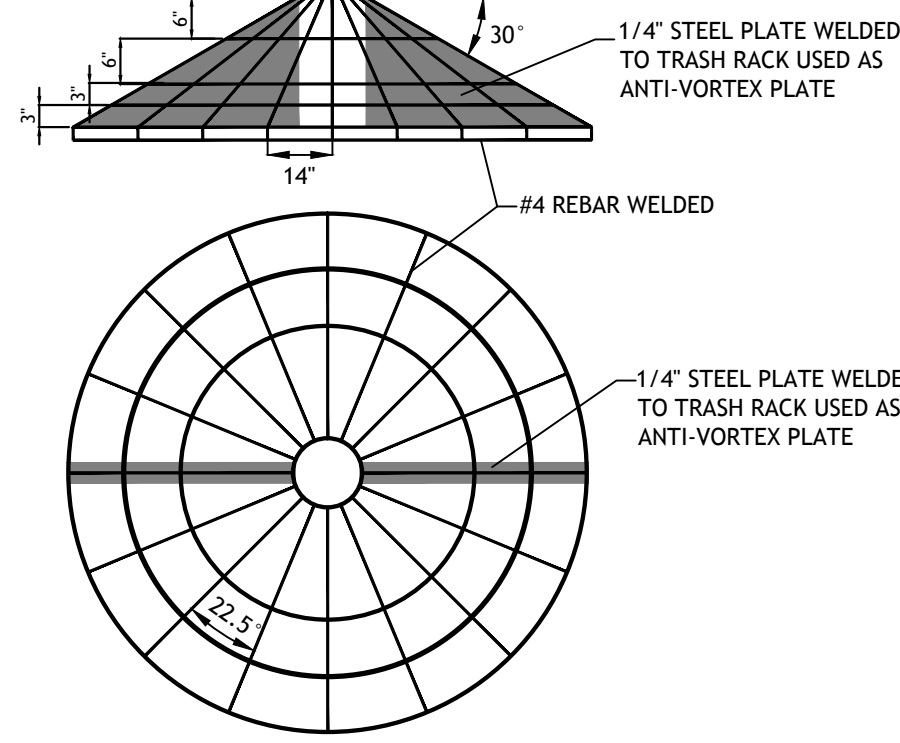

TYPICAL CONICAL TRASH RACK W/ ANTI-VORTEX DEVICE
N.T.S

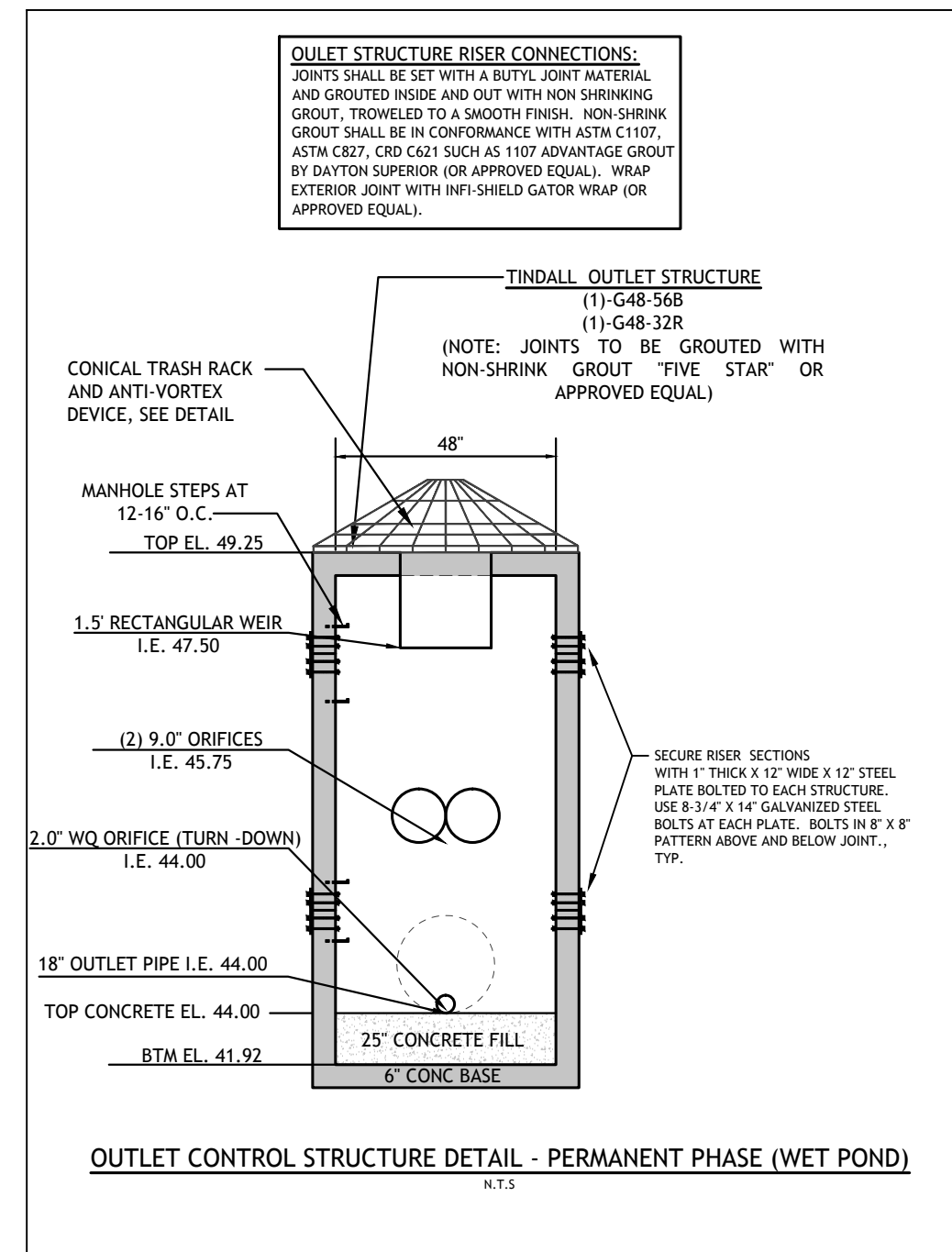

OUTLET CONTROL STRUCTURE DETAIL - PERMANENT PHASE (WET POND)

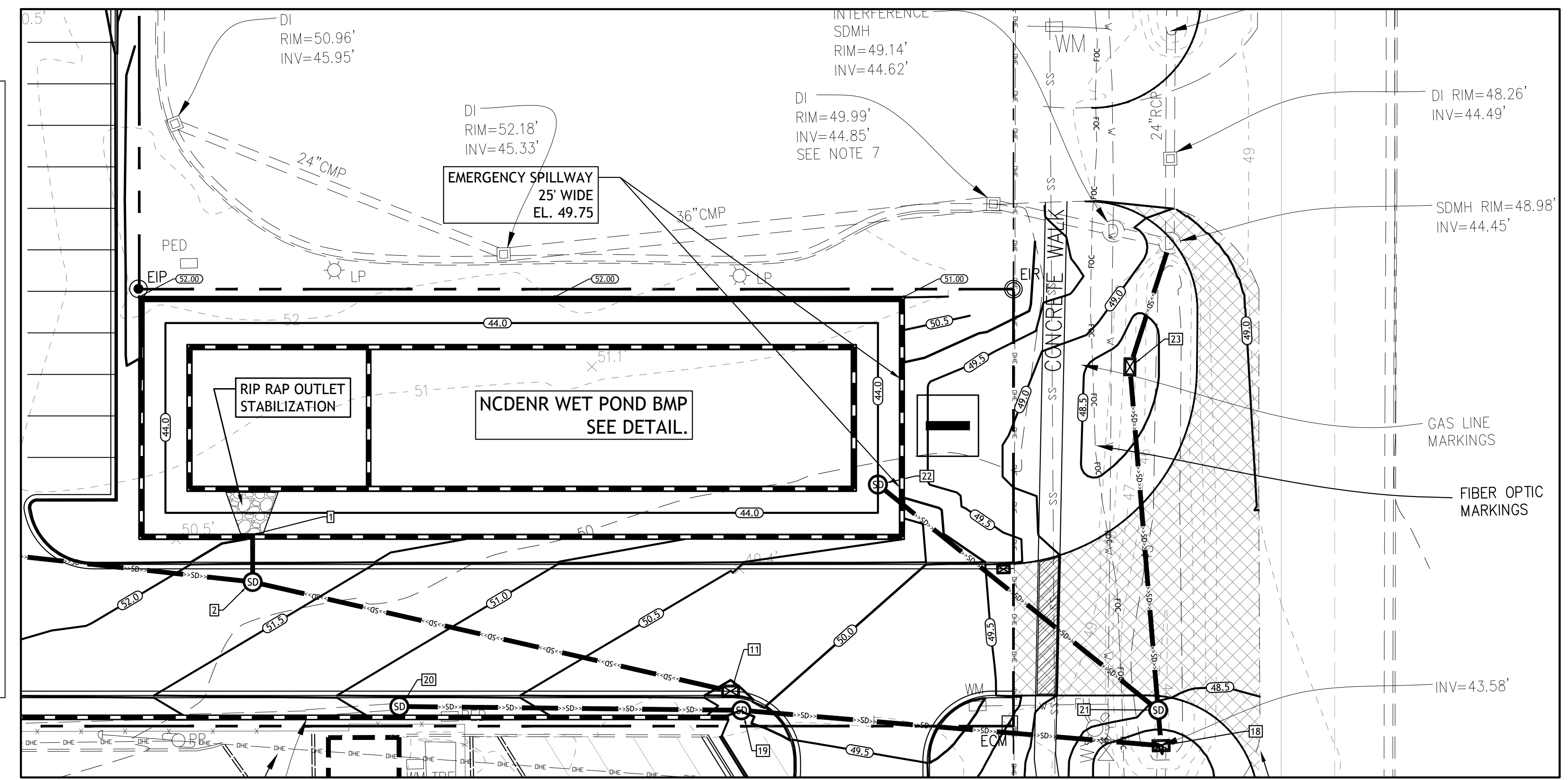

NCDNR WET POND BMP PLAN VIEW

1" = 20'

100 YEAR WSE 49.91
25 YEAR WSE 49.31
10 YEAR WSE 48.75
2 YEAR WSE 47.70
1 YEAR WSE 47.28

LITTORAL SHELF NOTES:
1. PLANT DENSITY SHALL EQUAL 50 PLANTS PER 200 S.F. OF SHELF:
4,125 S.F. OF SHELF = 1,032 PLANTS
2. PLANTS SHALL BE PLANTED IN AN EQUAL DISTRIBUTION. USE THE FOLLOWING NATIVE SPECIES:
SWEETFLAG - *acorus calamus*
BLUE FLAG IRIS - *iris virginica*
WOOL GRASS - *scirpus cyperinus*

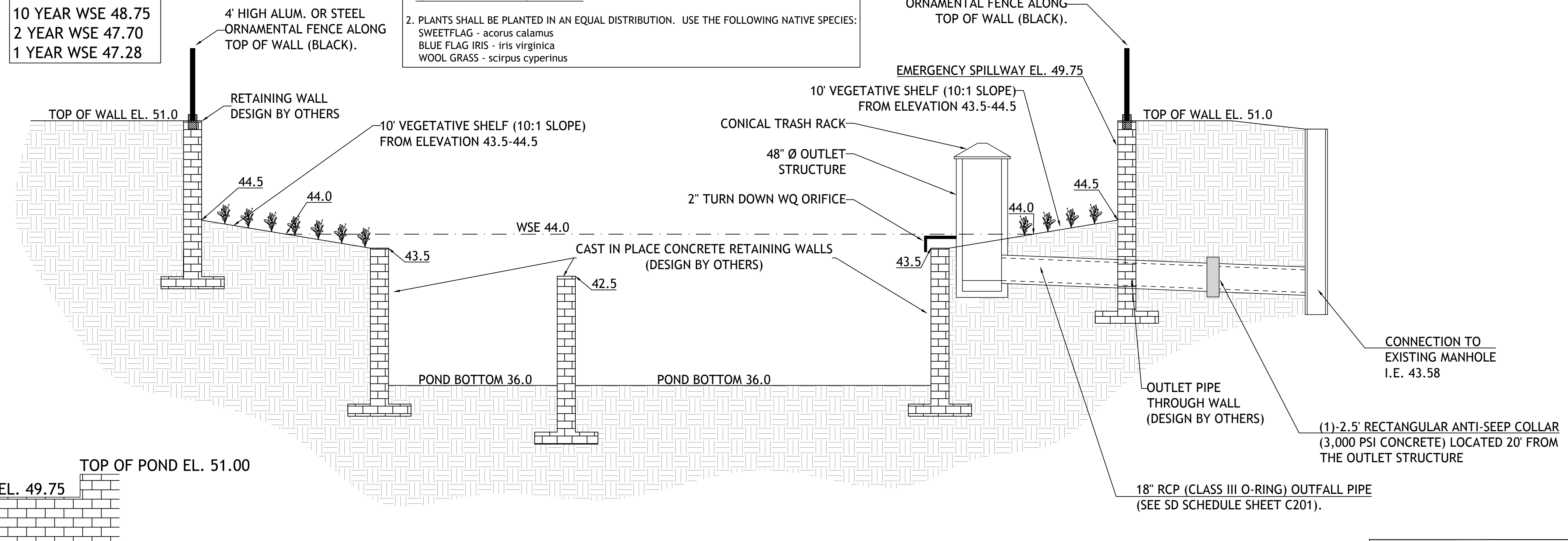

- TYPICAL SECTION -

NCDNR WET POND BMP DETAIL

NTS

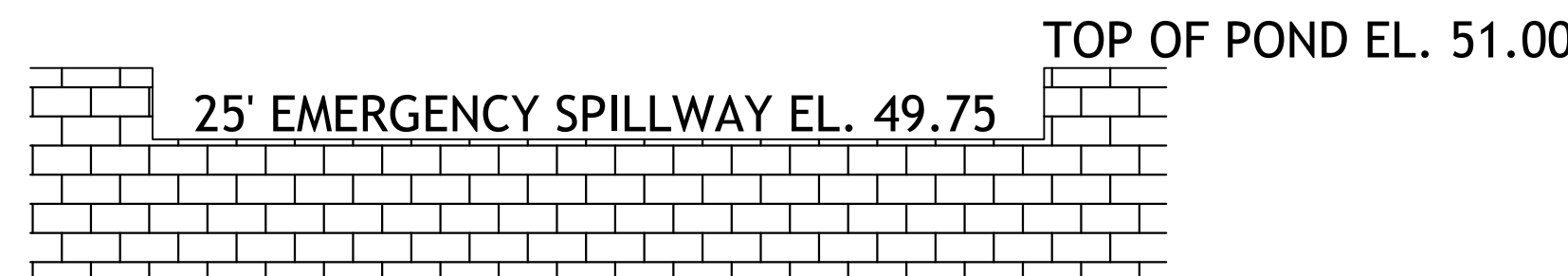

- TYPICAL SECTION -

EMERGENCY SPILLWAY DETAIL

NTS

Project Number: 2014-090
DWG Name: 2014-090 D1.dwg
Drawing Scale: AS NOTED
Date of Project: 10-21-2014
Engineer of Record:
Jason Henderson, P.E.
South Carolina PE# 22466
Georgia PE# 03571
North Carolina PE# 031306
Alabama PE# 38895
Louisiana PE# 38895
Virginia PE# 60203318

bluewater
civil design, PLLC
bluewatercivil.com • info@bluewatercivil.com
19 Washington Park Suite 100 • Greenville, SC 29601

Certificates of Authorization:
SC C04212 - GA PE#005865
NC P0868 - AL CA4065E

Bragg Road Dev. Company, LLC
Bragg Drive
Wilmington, NC

Approved Construction Plan	Plan
Name	Date
Planning	Traffic
Fire	Fire



Bluewater Civil Design, PLLC
NC-P-0868

PLAN REVISION	ISSUE DATE	ISSUE COMMENT
A	2-3-2015	ISSUED FOR PERMITS

City of **WILMINGTON**
NORTH CAROLINA
Public Services • Engineering Division
APPROVED STORMWATER MANAGEMENT PLAN
Date: _____ Permit # _____
Signed: _____

WET POND BMP PLAN & DETAILS

C201-B

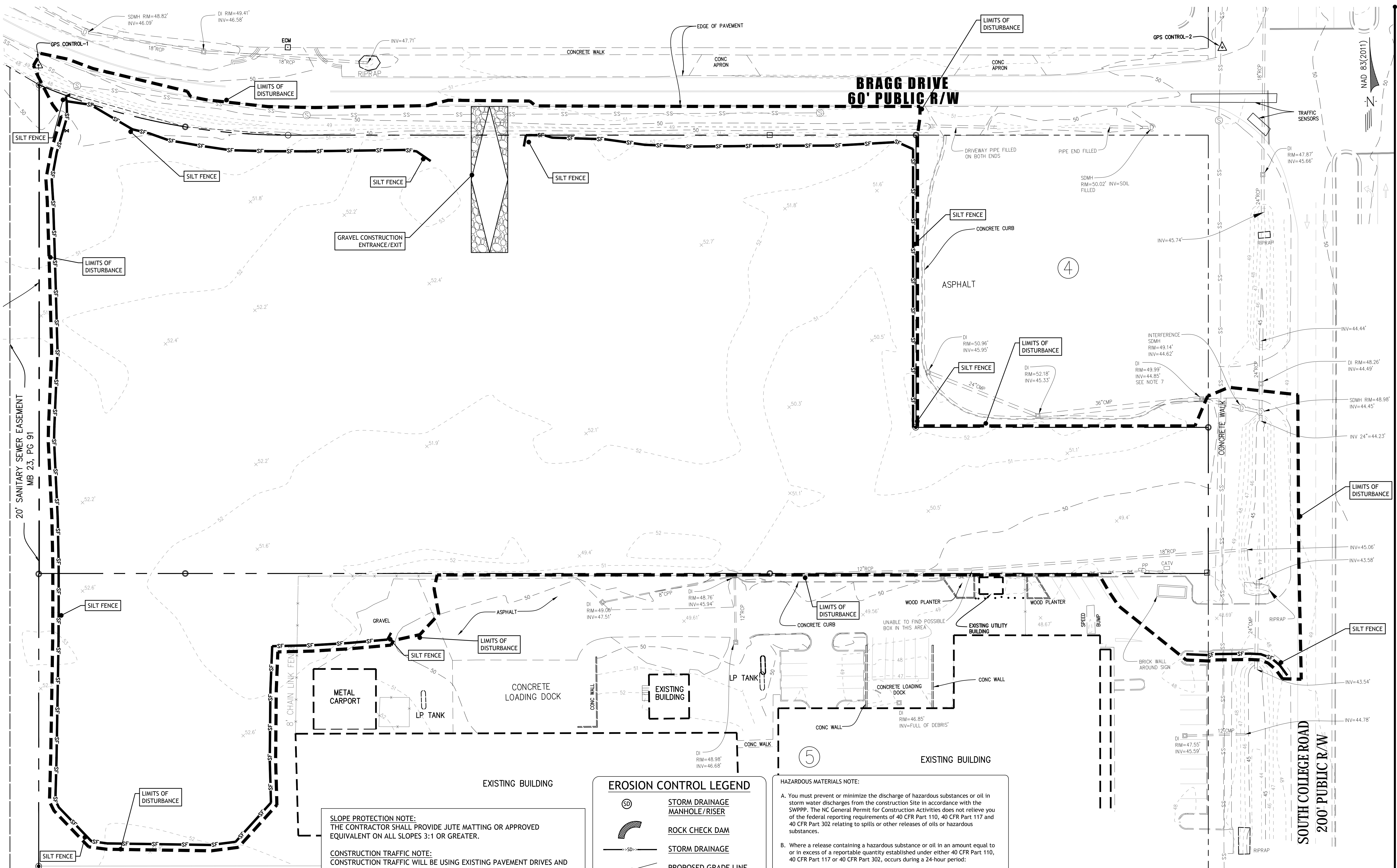

SLOPE PROTECTION NOTE:
THE CONTRACTOR SHALL PROVIDE JUTE MATTING OR APPROVED EQUIVALENT ON ALL SLOPES 3:1 OR GREATER.

CONSTRUCTION TRAFFIC NOTE:
CONSTRUCTION TRAFFIC WILL BE USING EXISTING PAVEMENT DRIVES AND SHALL INSURE THAT THEY ARE NOT TRACKING SEDIMENT OFF-SITE. CONTRACTOR SHALL MONITOR AND WASH OFF TIRES IF REQUIRED.

MAINTENANCE STATEMENT:
EROSION CONTROL MEASURES WILL BE MAINTAINED AT ALL TIMES. IF FULL IMPLEMENTATION OF THE APPROVED PLAN DOES NOT PROVIDE FOR EFFECTIVE EROSION CONTROL, ADDITIONAL EROSION CONTROL AND SEDIMENT CONTROL MEASURES SHALL BE IMPLEMENTED TO CONTROL OR TREAT THE SEDIMENT SOURCE.

DUST CONTROL:
THE CONTRACTOR SHALL USE ALL REASONABLE MEANS (e.g. WATER TRUCK, TARPS, MULCH, GRASSING, ETC.) NECESSARY TO REDUCE DUST DURING DEMOLITION AND CONSTRUCTION.

EROSION CONTROL LEGEND

- STORM DRAINAGE MANHOLE/RISER
- ROCK CHECK DAM
- STORM DRAINAGE
- PROPOSED GRADE LINE
- SILT FENCE
- SILT SAVER
- SEDIMENT TUBES
- DISTURBED LIMITS
- DIVERSION SWALE/BERM
- CONSTRUCTION ENTRANCE

HAZARDOUS MATERIALS NOTE:

A. You must prevent or minimize the discharge of hazardous substances or oil in storm water discharges from the construction Site in accordance with the SWPPP. The NC General Permit for Construction Activities does not relieve you of the federal reporting requirements of 40 CFR Part 110, 40 CFR Part 117 and 40 CFR Part 302 relating to spills or other releases of oils or hazardous substances.

B. Where a release containing a hazardous substance or oil in an amount equal to or in excess of a reportable quantity established under either 40 CFR Part 110, 40 CFR Part 117 or 40 CFR Part 302, occurs during a 24-hour period:

- You must notify the NCDENR's Emergency Response Section at 800-258-0368 and the National Response Center (NRC) (800) 424-8802 in accordance with the requirements of 40 CFR Part 110, 40 CFR Part 117 and 40 CFR Part 302 as soon as Site staff have knowledge of the discharge; and
- You must modify the SWPPP as required under Subpart 3.11 within 14 calendar days of knowledge of the release to: provide a description of the release, the circumstances leading to the release, and the date of the release. In addition, you must review your SWPPP to identify measures to prevent the reoccurrence of such releases and to respond to such releases, and you must modify your SWPPP where appropriate.

GENERAL EROSION CONTROL NOTE:
ALL EROSION CONTROL MEASURES SHALL BE INSTALLED AND MAINTAINED PER N.C.D.E.N.R. BMP MANUAL. THE CONTRACTOR SHALL REFERENCE THE STORMWATER POLLUTION PREVENTION MANUAL (SWPPP) FOR ALL EROSION CONTROL PROCEDURES ON SITE.

DISTURBANCE NOTE:
STABILIZATION MEASURES SHALL BE INITIATED AS SOON AS PRACTICE IN PORTIONS OF THE SITE WHERE CONSTRUCTION ACTIVITIES HAVE TEMPORARILY OR PERMANENTLY CEASED, BUT IN NO CASE MORE THAN FOURTEEN (14) DAYS AFTER WORK HAS CEASED.

NOTE:
TEMPORARY CONSTRUCTION SIGNS SHALL NOT BE PLACED WITHIN THE ROAD RIGHT OF WAY OR SIGHT TRIANGLES.

811 Know what's below. Call before you dig.

DIGALERT

GRAPHIC SCALE
(IN FEET)
1 inch = 30 ft.

NAD 83 (2011)

Project Number: 2014-090
 DWG Name: 2014-090 D1.dwg
 Drawing Scale: AS NOTED
 Date of Project: 10-21-2014
 Engineer of Record:
 Jason Henderson, P.E.
 South Carolina REG 21466
 Georgia REG 03871
 North Carolina REG 03106
 Alabama REG 13214
 Louisiana REG 38891
 Virginia REG 60203118

bluewater
civil design, PLLC
 bluewater civil design, PLLC
 19 Washington Park Suite 100 • Greenville, SC 29601
 www.bluewatercivil.com • info@bluewatercivil.com

BRAGG ROAD DEV. COMPANY, LLC
 Bragg Drive
 Wilmington, NC

Approved Construction Plan
 Name: _____
 Date: _____
 Planning: _____
 Traffic: _____
 Fire: _____



Bluewater Civil Design, PLLC
 NC-P-0868

PLAN REVISION	ISSUE DATE	ISSUE COMMENT
A	2-3-2015	ISSUED FOR PERMITS

PHASE I EROSION CONTROL PLAN - PERIMETER

C202

CITY OF WILMINGTON
 NORTH CAROLINA
 Public Services • Engineering Division
 APPROVED STORMWATER MANAGEMENT PLAN
 Date: _____ Permit # _____
 Signed: _____

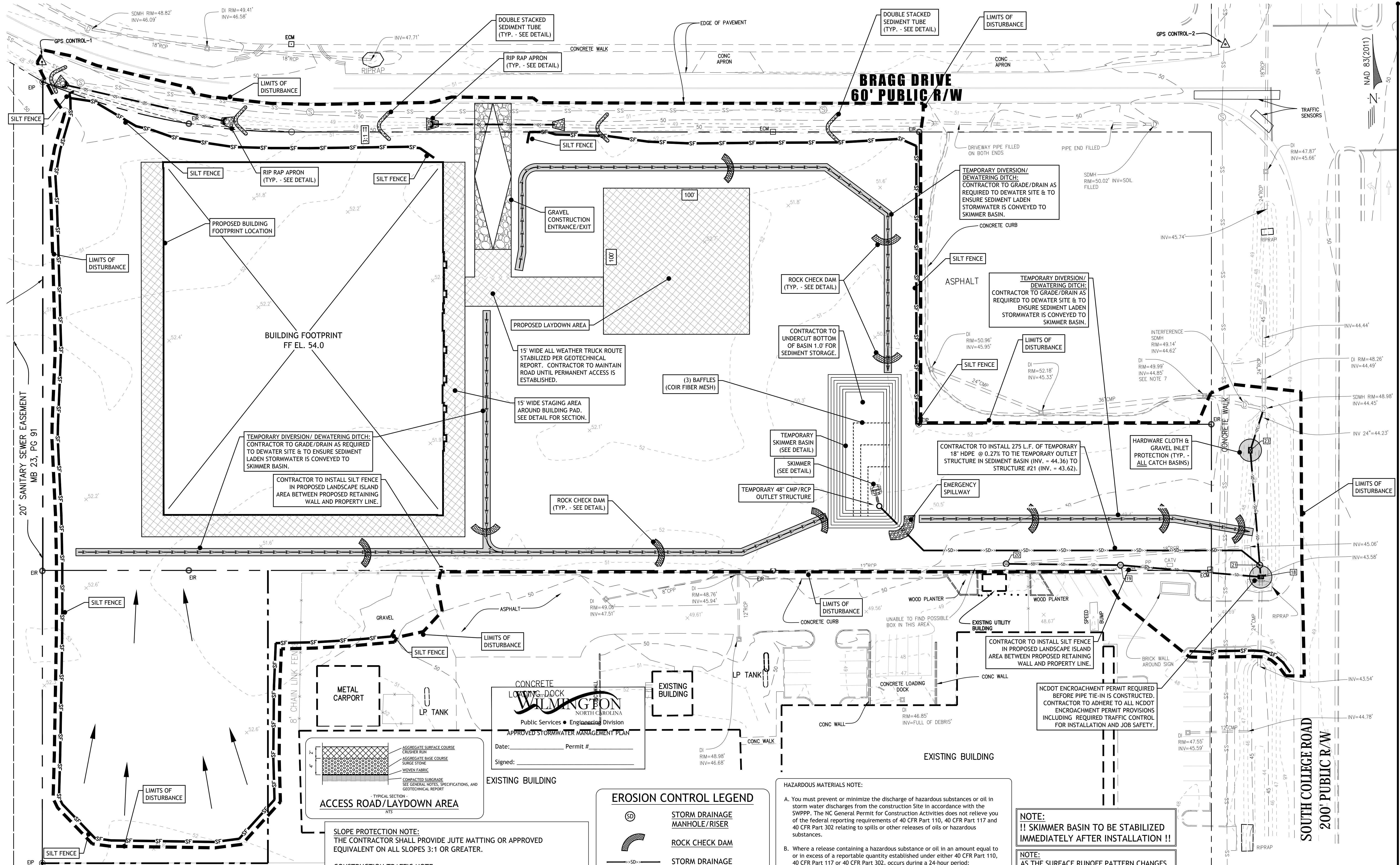

Project Number: 2014-090
 DWG Name: 2014-090 D1.dwg
 Drawing Scale: AS NOTED
 Date of Project: 10-21-2014
 Engineer of Record:
 Jason Henderson, P.E.
 South Carolina PE# 21406
 Georgia PE# 03571
 North Carolina PE# 01306
 Alabama PE# 21054
 Louisiana PE# 38891
 Virginia PE# 60203118

bluewater
 civil design, PLLC
 bluewatercivil.com • info@bluewatercivil.com
 19 Washington Park Suite 100 • Greenville, SC 29601
 www.bluewatercivil.com

BRAGG ROAD DEV. COMPANY, LLC
 Bragg Drive
 Wilmington, NC

Approved Construction Plan
 Name: _____
 Date: _____
 Planning: _____
 Traffic: _____
 Fire: _____

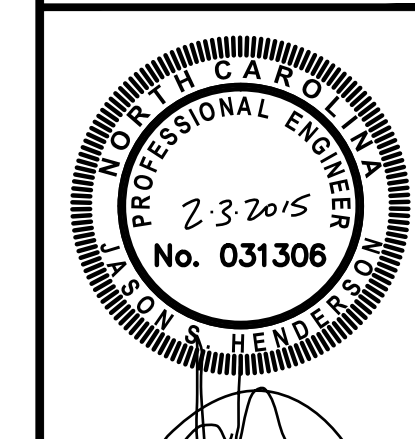

Bluewater Civil Design, PLLC
 NCP-0868

PLAN REVISION	ISSUE DATE	ISSUE COMMENT
A	2-3-2015	ISSUED FOR PERMITS

PHASE II-A EROSION CONTROL PLAN

C203

SLOPE PROTECTION NOTE:
 THE CONTRACTOR SHALL PROVIDE JUTE MATTING OR APPROVED EQUIVALENT ON ALL SLOPES 3:1 OR GREATER.

CONSTRUCTION TRAFFIC NOTE:
 CONSTRUCTION TRAFFIC WILL BE USING EXISTING PAVEMENT DRIVES AND SHALL INSURE THAT THEY ARE NOT TRACKING SEDIMENT OFF-SITE. CONTRACTOR SHALL MONITOR AND WASH OFF TIRES IF REQUIRED.

MAINTENANCE STATEMENT:
 EROSION CONTROL MEASURES WILL BE MAINTAINED AT ALL TIMES. IF FULL IMPLEMENTATION OF THE APPROVED PLAN DOES NOT PROVIDE FOR EFFECTIVE EROSION CONTROL, ADDITIONAL EROSION CONTROL AND SEDIMENT CONTROL MEASURES SHALL BE IMPLEMENTED TO CONTROL OR TREAT THE SEDIMENT SOURCE.

DUST CONTROL:
 THE CONTRACTOR SHALL USE ALL REASONABLE MEANS (e.g. WATER TRUCK, TARPS, MULCH, GRASSING, ETC.) NECESSARY TO REDUCE DUST DURING DEMOLITION AND CONSTRUCTION.

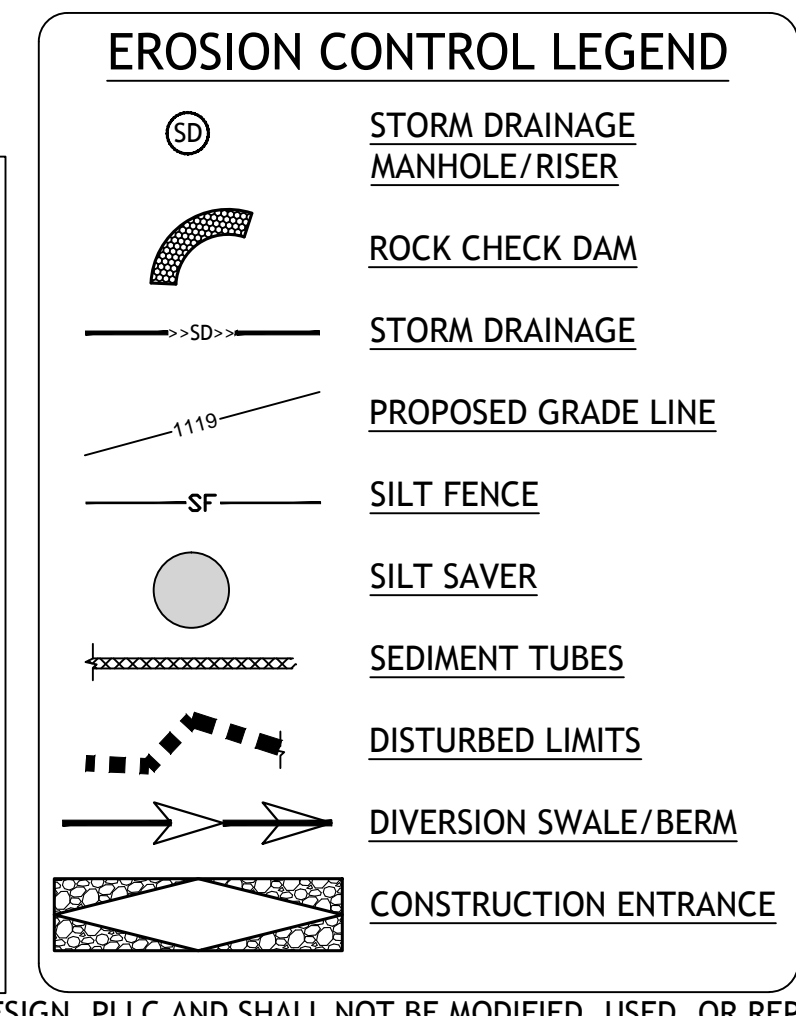

HAZARDOUS MATERIALS NOTE:

A. You must prevent or minimize the discharge of hazardous substances or oil in storm water discharges from the construction site in accordance with the SWPPP. The NC General Permit for Construction Activities does not relieve you of the federal reporting requirements of 40 CFR Part 110, 40 CFR Part 117 and 40 CFR Part 302 relating to spills or other releases of oils or hazardous substances.

B. Where a release containing a hazardous substance or oil in an amount equal to or in excess of a reportable quantity established under either 40 CFR Part 110, 40 CFR Part 117 or 40 CFR Part 302, occurs during a 24-hour period:

- You must notify the NCDENR's Emergency Response Section at 800-258-0368 and the National Response Center (NRC) (800) 424-8802 in accordance with the requirements of 40 CFR Part 110, 40 CFR Part 117 and 40 CFR Part 302 as soon as Site staff have knowledge of the discharge; and
- You must modify the SWPPP as required under Subpart 3.11 within 14 calendar days of knowledge of the release to: provide a description of the release, the circumstances leading to the release, and the date of the release. In addition, you must review your SWPPP to identify measures to prevent the reoccurrence of such releases and to respond to such releases, and you must modify your SWPPP where appropriate.

GENERAL EROSION CONTROL NOTE:
 ALL EROSION CONTROL MEASURES SHALL BE INSTALLED AND MAINTAINED PER N.C.D.E.N.R. BMP MANUAL. THE CONTRACTOR SHALL REFERENCE THE STORMWATER POLLUTION PREVENTION MANUAL (SWPPP) FOR ALL EROSION CONTROL PROCEDURES ON SITE.

NOTE:
 !! SKIMMER BASIN TO BE STABILIZED IMMEDIATELY AFTER INSTALLATION !!

NOTE:
 AS THE SURFACE RUNOFF PATTERN CHANGES DURING CONSTRUCTION, ADDITIONAL TEMPORARY DIVERSION DITCHES MAY BE NECESSARY TO DIRECT FLOW TO THE TEMPORARY SKIMMER BASIN.

DISTURBANCE NOTE:
 STABILIZATION MEASURES SHALL BE INITIATED AS SOON AS PRACTICABLE IN PORTIONS OF THE SITE WHERE CONSTRUCTION ACTIVITIES HAVE TEMPORARILY OR PERMANENTLY CEASED, BUT IN NO CASE MORE THAN FOURTEEN (14) DAYS AFTER WORK HAS CEASED.

NOTE:
 TEMPORARY CONSTRUCTION SIGNS SHALL NOT BE PLACED WITHIN THE ROAD RIGHT OF WAY OR SIGHT TRIANGLES.

STORM DRAINAGE NOTES:

- PIPES ON-SITE AND WITHIN SCOTD RIGHT OF WAY HAVE BEEN DESIGNED FOR THE 10-YEAR STORM EVENT AT A 5 MIN. DURATION (INTENSITY = 6.7 IN/HR.)
- ALL PIPE WITHIN NCDOT RIGHT OF WAY TO BE REINFORCED CONCRETE PIPE (RCP).
- ALL PIPE JOINTS SHALL BE WRAPPED WITH A FILTER FABRIC IN 18-INCH WIDE SECTIONS UTILIZING, AT A MINIMUM, FABRIC WITH A MASS PER UNIT AREA OF: (ENGLISH MEASURE) 5.0 OUNCES PER SQUARE YARD AND A THICKNESS OF 60 MILS - OR - (METRIC MEASURE) 170.0 GRAMS PER SQUARE METER AND A THICKNESS OF 1.5 MILLIMETERS.
- ALL PIPE LENGTHS SHOWN ON THE STORM DRAINAGE TABLE ARE APPROXIMATE. IT IS THE RESPONSIBILITY OF THE CONTRACTOR TO DETERMINE ACTUAL FIELD LENGTHS.
- ALL PIPES SHALL BE REINFORCED CONCRETE PIPE (RCP) PIPE, SEE SCHEDULE FOR CLASS INFORMATION.
- *DROP STRUCTURE INDICATED WHERE TWO (2) OR MORE PIPES DISCHARGE INTO SAME STRUCTURE AT DIFFERENT ELEVATIONS.

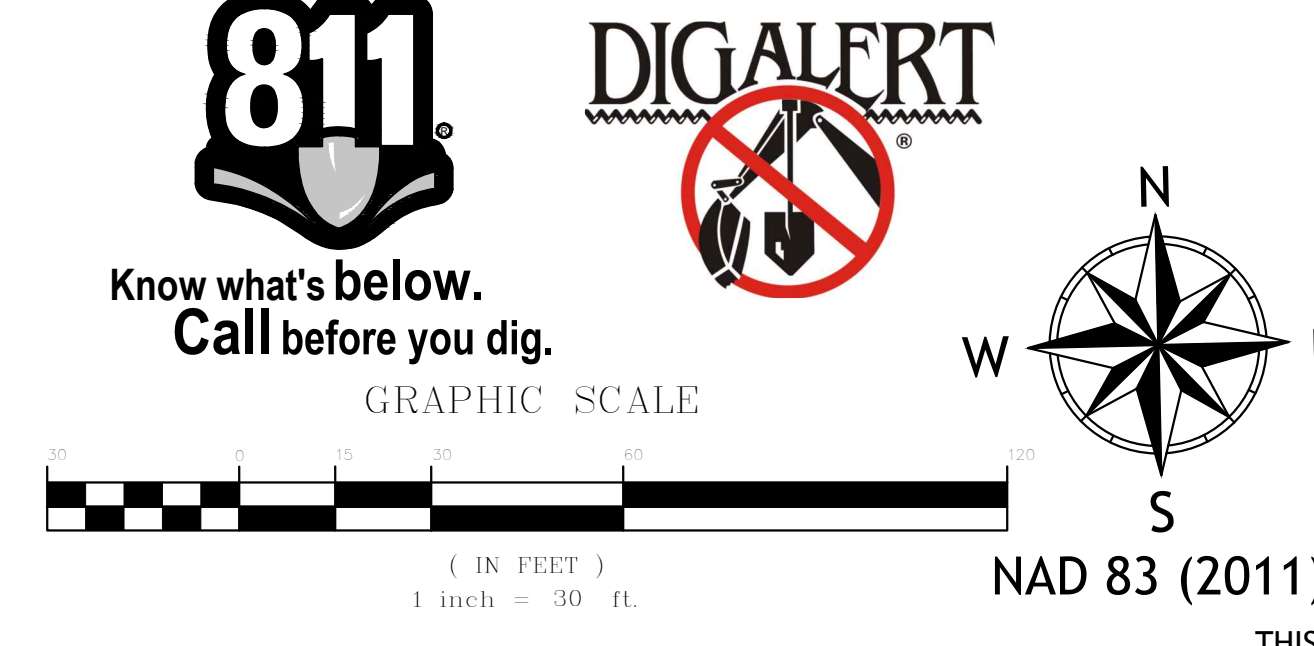

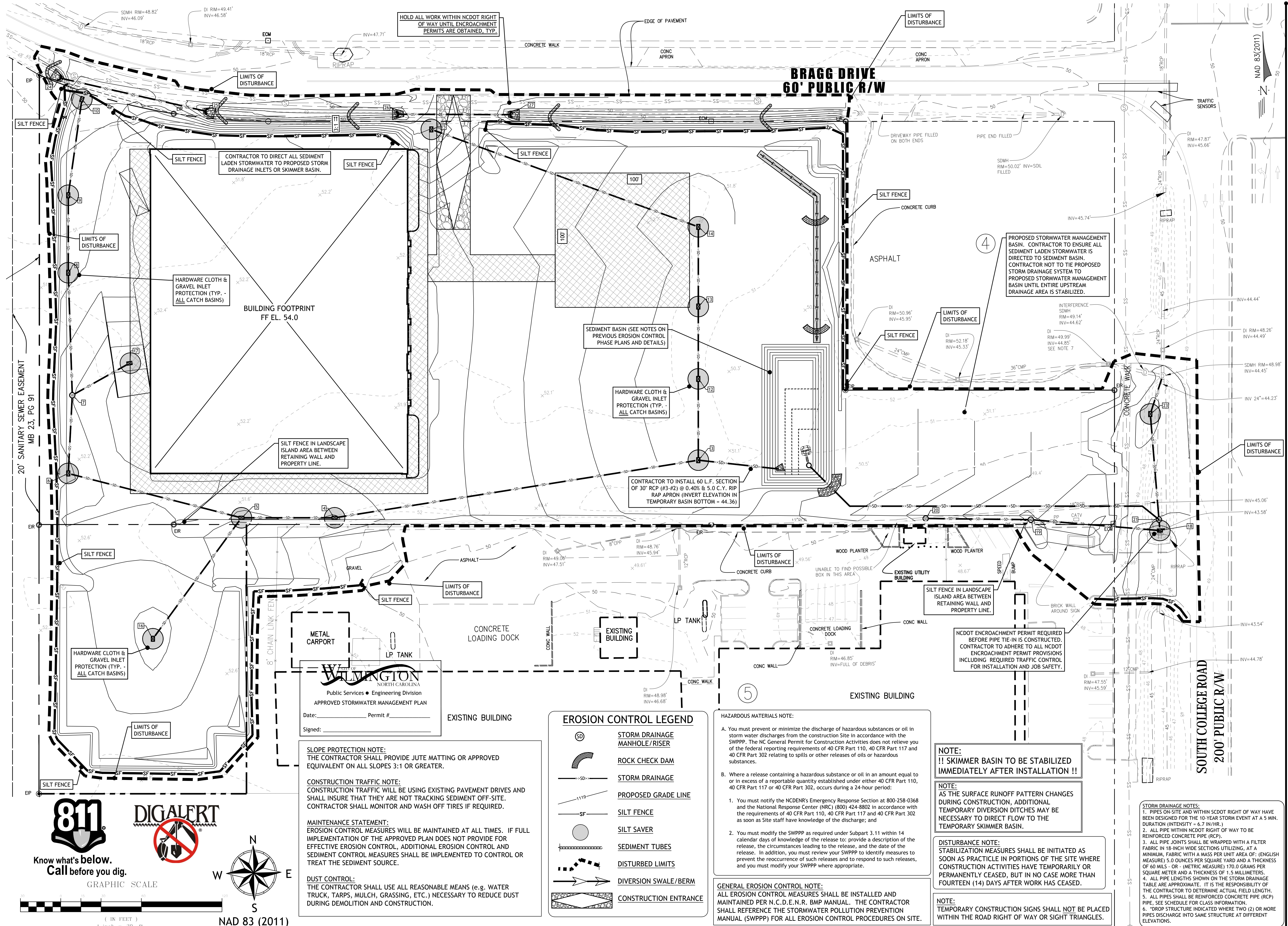

Project Number: 2014-090
 DWG Name: 2014-090 D1.dwg
 Drawing Scale: AS NOTED
 Date of Project: 10-21-2014
 Engineer of Record:
 Jason Henderson, P.E.
 South Carolina PE# 21406
 Georgia PE# 03571
 North Carolina PE# 01306
 Alabama PE# 37054
 Louisiana PE# 38891
 Virginia PE# 60203138

blue water
 civil design, PLLC
 bluewatercivil.com • info@bluewatercivil.com
 19 Washington Park Suite 100 • Greenville, SC 29601
 www.bluewatercivil.com

Certificates of Authorization:
 NC 04212 - GA PEF005865
 NC P0868 - AL CA4065E

BRAGG ROAD DEV. COMPANY, LLC
 Bragg Drive
 Wilmington, NC

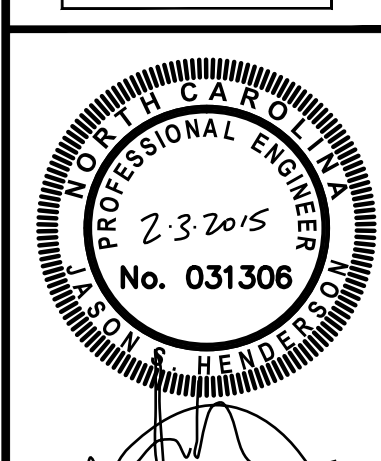

Bluewater Civil Design, PLLC
 NC-P-0868

PLN REVISION	ISSUED DATE	ISSUE COMMENT
A	2-3-2015	ISSUED FOR PERMITS

PHASE II-B EROSION CONTROL PLAN

C204

CITY OF WILMINGTON
 NORTH CAROLINA
 Public Services • Engineering Division
 APPROVED STORMWATER MANAGEMENT PLAN
 Date: _____ Permit # _____
 Signed: _____

SLOPE PROTECTION NOTE:
 THE CONTRACTOR SHALL PROVIDE JUTE MATTING OR APPROVED EQUIVALENT ON ALL SLOPES 3:1 OR GREATER.

CONSTRUCTION TRAFFIC NOTE:
 CONSTRUCTION TRAFFIC WILL BE USING EXISTING PAVEMENT DRIVES AND SHALL INSURE THAT THEY ARE NOT TRACKING SEDIMENT OFF-SITE. CONTRACTOR SHALL MONITOR AND WASH OFF TIRES IF REQUIRED.

MAINTENANCE STATEMENT:
 EROSION CONTROL MEASURES WILL BE MAINTAINED AT ALL TIMES. IF FULL IMPLEMENTATION OF THE APPROVED PLAN DOES NOT PROVIDE FOR EFFECTIVE EROSION CONTROL, ADDITIONAL EROSION CONTROL AND SEDIMENT CONTROL MEASURES SHALL BE IMPLEMENTED TO CONTROL OR TREAT THE SEDIMENT SOURCE.

DUST CONTROL:
 THE CONTRACTOR SHALL USE ALL REASONABLE MEANS (e.g. WATER TRUCK, TARPS, MULCH, GRASSING, ETC.) NECESSARY TO REDUCE DUST DURING DEMOLITION AND CONSTRUCTION.

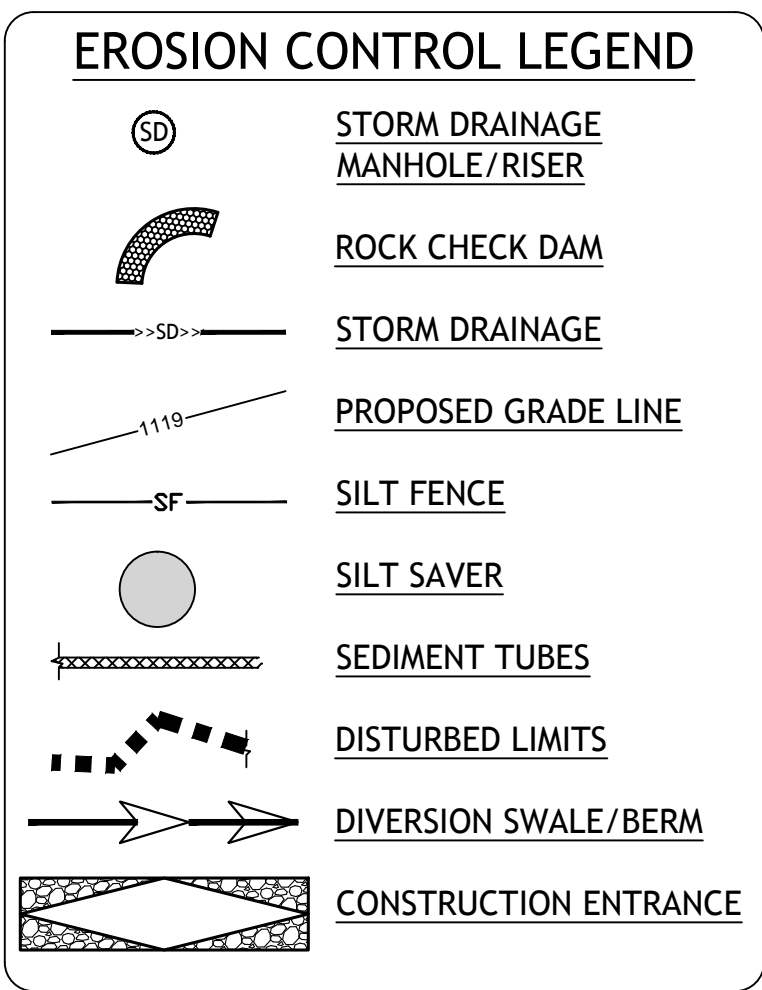

HAZARDOUS MATERIALS NOTE:

A. You must prevent or minimize the discharge of hazardous substances or oil in storm water discharges from the construction Site in accordance with the SWPPP. The NC General Permit for Construction Activities does not relieve you of the federal reporting requirements of 40 CFR Part 110, 40 CFR Part 117 and 40 CFR Part 302 relating to spills or other releases of oils or hazardous substances.

B. Where a release containing a hazardous substance or oil in an amount equal to or in excess of a reportable quantity established under either 40 CFR Part 110, 40 CFR Part 117 or 40 CFR Part 302, occurs during a 24-hour period:

- You must notify the NCDENR's Emergency Response Section at 800-258-0368 and the National Response Center (NRC) (800) 424-8802 in accordance with the requirements of 40 CFR Part 110, 40 CFR Part 117 and 40 CFR Part 302 as soon as Site staff have knowledge of the discharge; and
- You must modify the SWPPP as required under Subpart 3.11 within 14 calendar days of knowledge of the release to: provide a description of the release, the circumstances leading to the release, and the date of the release. In addition, you must review your SWPPP to identify measures to prevent the recurrence of such releases and to respond to such releases, and you must modify your SWPPP where appropriate.

GENERAL EROSION CONTROL NOTE:
 ALL EROSION CONTROL MEASURES SHALL BE INSTALLED AND MAINTAINED PER N.C.D.E.N.R. BMP MANUAL. THE CONTRACTOR SHALL REFERENCE THE STORMWATER POLLUTION PREVENTION MANUAL (SWPPP) FOR ALL EROSION CONTROL PROCEDURES ON SITE.

NOTE:
 !! SKIMMER BASIN TO BE STABILIZED IMMEDIATELY AFTER INSTALLATION !!

NOTE:
 AS THE SURFACE RUNOFF PATTERN CHANGES DURING CONSTRUCTION, ADDITIONAL TEMPORARY DIVERSION DITCHES MAY BE NECESSARY TO DIRECT FLOW TO THE TEMPORARY SKIMMER BASIN.

DISTURBANCE NOTE:
 STABILIZATION MEASURES SHALL BE INITIATED AS SOON AS PRACTICABLE IN PORTIONS OF THE SITE WHERE CONSTRUCTION ACTIVITIES HAVE TEMPORARILY OR PERMANENTLY CEASED, BUT IN NO CASE MORE THAN FOURTEEN (14) DAYS AFTER WORK HAS CEASED.

NOTE:
 TEMPORARY CONSTRUCTION SIGNS SHALL NOT BE PLACED WITHIN THE ROAD RIGHT OF WAY OR SIGHT TRIANGLES.

STORM DRAINAGE NOTES:

- PIPES ON-SITE AND WITHIN SCOTD RIGHT OF WAY HAVE BEEN DESIGNED FOR THE 10-YEAR STORM EVENT AT A 5 MIN. DURATION (INTENSITY = 6.7 IN/HR.)
- ALL PIPE WITHIN NCDOT RIGHT OF WAY TO BE REINFORCED CONCRETE PIPE (RCP).
- ALL PIPE JOINTS SHALL BE WRAPPED WITH A FILTER FABRIC IN 18-INCH WIDE SECTIONS UTILIZING, AT A MINIMUM, FABRIC WITH A MASS PER UNIT AREA OF: (ENGLISH MEASURE) 5.0 OUNCES PER SQUARE YARD AND A THICKNESS OF 60 MILS - OR - (METRIC MEASURE) 170.0 GRAMS PER SQUARE METER AND A THICKNESS OF 1.5 MILLIMETERS.
- ALL PIPE LENGTHS SHOWN ON THE STORM DRAINAGE TABLE ARE APPROXIMATE. IT IS THE RESPONSIBILITY OF THE CONTRACTOR TO DETERMINE ACTUAL FIELD LENGTHS.
- ALL PIPES SHALL BE REINFORCED CONCRETE PIPE (RCP) PIPE, SEE SCHEDULE FOR CLASS INFORMATION.
- *DROP STRUCTURE INDICATED WHERE TWO (2) OR MORE PIPES DISCHARGE INTO SAME STRUCTURE AT DIFFERENT ELEVATIONS.

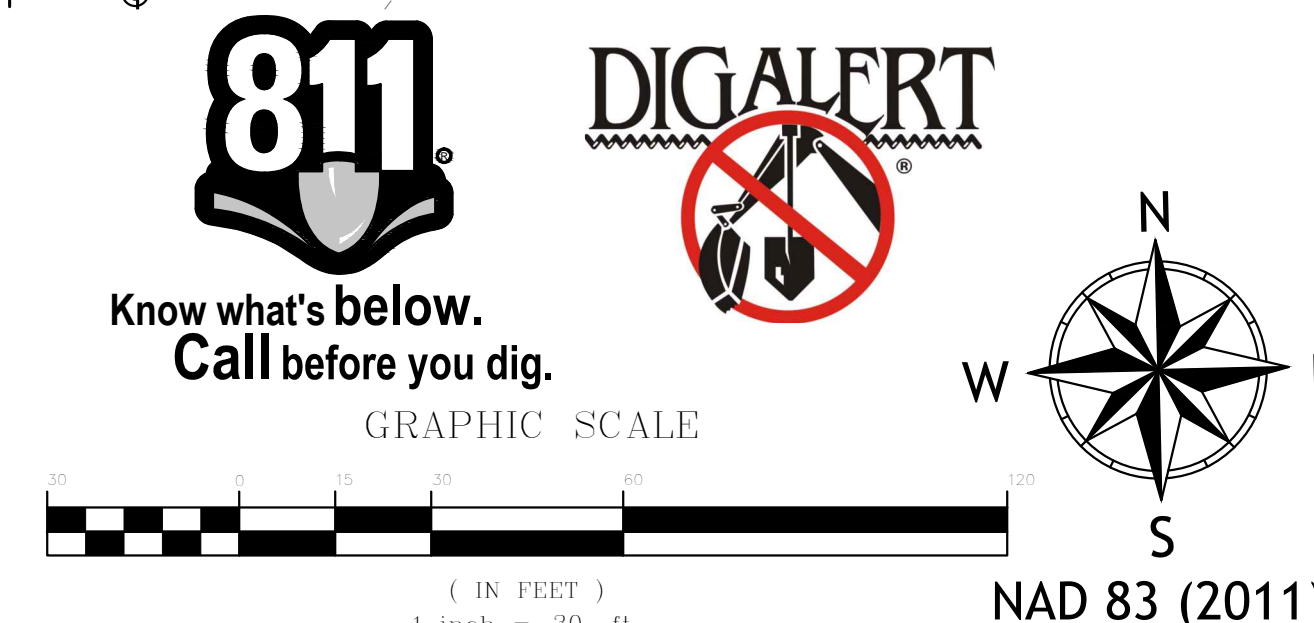

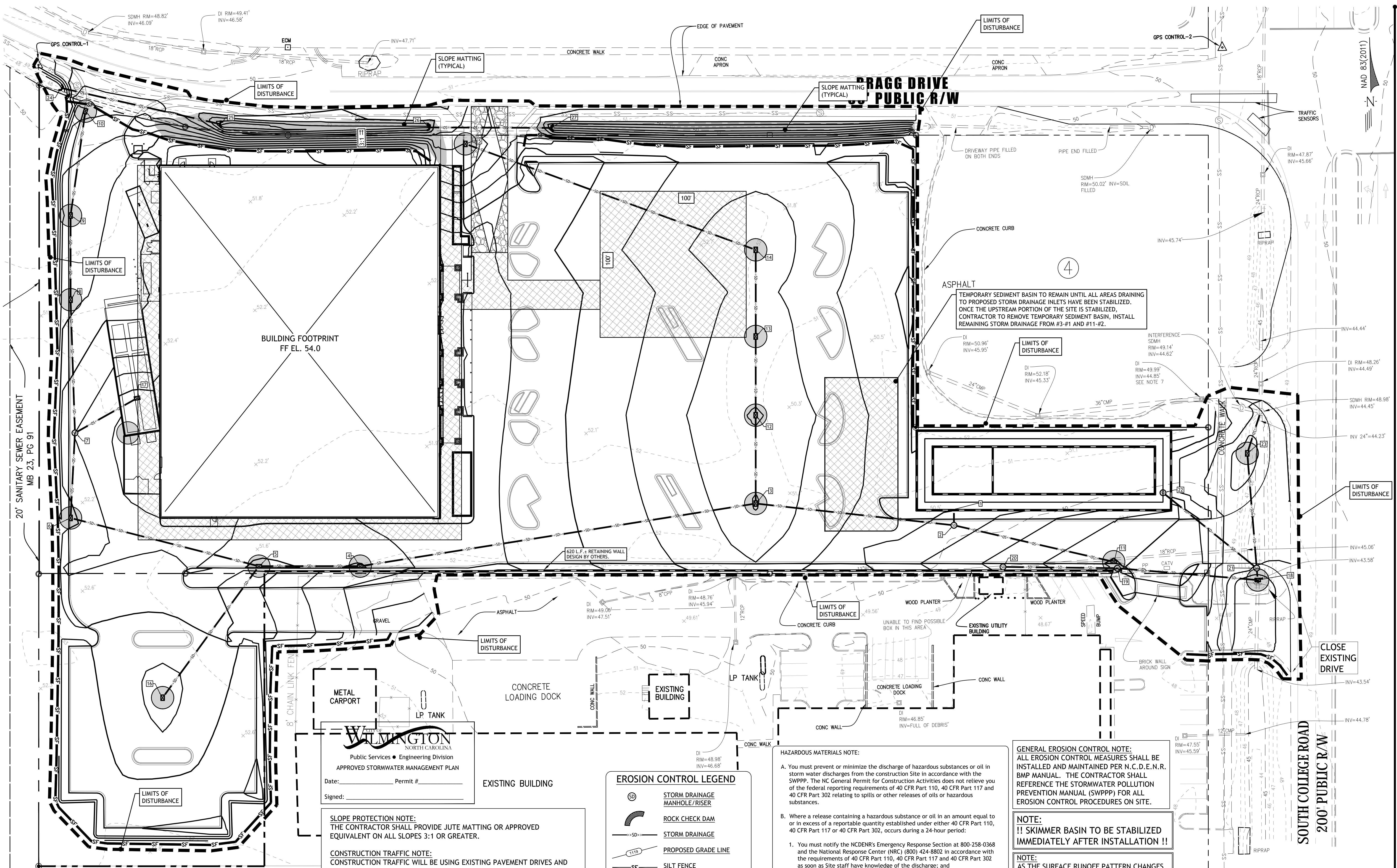

20' SANITARY SEWER EASEMENT
MB 23, PG 91

Project Number: 2014-090
 DWG Name: 2014-090 D1.dwg
 Drawing Scale: AS NOTED
 Date of Project: 10-21-2014
 Engineer of Record:
 Jason Henderson, P.E.
 South Carolina PE# 21466
 Georgia PE# 03571
 North Carolina PE# 01306
 Alabama PE# 32054
 Louisiana PE# 38891
 Virginia PE# 60203138

blue WATER
 civil design
 bluewater civil design, PLLC
 19 Washington Park Suite 100 • Greenville, SC 29601
 www.bluewatercivil.com • info@bluewatercivil.com

Certificates of Authorization:
 SC CD4212 - GA PEF005865
 NC P0868 - AL CA4065E

BRAGG ROAD DEV. COMPANY, LLC
 Bragg Drive
 Wilmington, NC

Approved Construction Plan
 Name: _____ Date: _____
 Planning: _____ Traffic: _____
 Fire: _____

Professional Engineer
 Jason Henderson
 No. 031306
 State of North Carolina
 Bluewater Civil Design, PLLC
 NC-P-0868

PLAN REVISION	ISSUE DATE	ISSUE COMMENT
A	2-3-2015	ISSUED FOR PERMITS

PHASE III EROSION CONTROL PLAN
C205

WILMINGTON
 NORTH CAROLINA
 Public Services • Engineering Division
 APPROVED STORMWATER MANAGEMENT PLAN
 Date: _____ Permit # _____
 Signed: _____

SLOPE PROTECTION NOTE:
 THE CONTRACTOR SHALL PROVIDE JUTE MATTING OR APPROVED EQUIVALENT ON ALL SLOPES 3:1 OR GREATER.

CONSTRUCTION TRAFFIC NOTE:
 CONSTRUCTION TRAFFIC WILL BE USING EXISTING PAVEMENT DRIVES AND SHALL INSURE THAT THEY ARE NOT TRACKING SEDIMENT OFF-SITE. CONTRACTOR SHALL MONITOR AND WASH OFF TIRES IF REQUIRED.

MAINTENANCE STATEMENT:
 EROSION CONTROL MEASURES WILL BE MAINTAINED AT ALL TIMES. IF FULL IMPLEMENTATION OF THE APPROVED PLAN DOES NOT PROVIDE FOR EFFECTIVE EROSION CONTROL, ADDITIONAL EROSION CONTROL AND SEDIMENT CONTROL MEASURES SHALL BE IMPLEMENTED TO CONTROL OR TREAT THE SEDIMENT SOURCE.

DUST CONTROL:
 THE CONTRACTOR SHALL USE ALL REASONABLE MEANS (e.g. WATER TRUCK, TARPS, MULCH, GRASSING, ETC.) NECESSARY TO REDUCE DUST DURING DEMOLITION AND CONSTRUCTION.

- EROSION CONTROL LEGEND**
- STORM DRAINAGE MANHOLE/RISER
 - ROCK CHECK DAM
 - STORM DRAINAGE
 - PROPOSED GRADE LINE
 - SILT FENCE
 - HARDWARE CLOTH & GRAVEL INLET PROTECTION
 - DISTURBED LIMITS
 - DIVERSION SWALE/BERM
 - CONSTRUCTION ENTRANCES
 - DOUBLE STACKED SEDIMENT TUBE
 - SKIMMER DEVICE
 - SLOPE MATTING (CURLEX II)

HAZARDOUS MATERIALS NOTE:

- A. You must prevent or minimize the discharge of hazardous substances or oil in storm water discharges from the construction site in accordance with the SWPPP. The NC General Permit for Construction Activities does not relieve you of the federal reporting requirements of 40 CFR Part 110, 40 CFR Part 117 and 40 CFR Part 302 relating to spills or other releases of oils or hazardous substances.
- B. Where a release containing a hazardous substance or oil in an amount equal to or in excess of a reportable quantity established under either 40 CFR Part 110, 40 CFR Part 117 or 40 CFR Part 302, occurs during a 24-hour period:
 1. You must notify the NCDENR's Emergency Response Section at 800-258-0368 and the National Response Center (NRC) (800) 424-8802 in accordance with the requirements of 40 CFR Part 110, 40 CFR Part 117 and 40 CFR Part 302 as soon as Site staff have knowledge of the discharge; and
 2. You must modify the SWPPP as required under Subpart 3.11 within 14 calendar days of knowledge of the release to: provide a description of the release, the circumstances leading to the release, and the date of the release. In addition, you must review your SWPPP to identify measures to prevent the recurrence of such releases and to respond to such releases, and you must modify your SWPPP where appropriate.

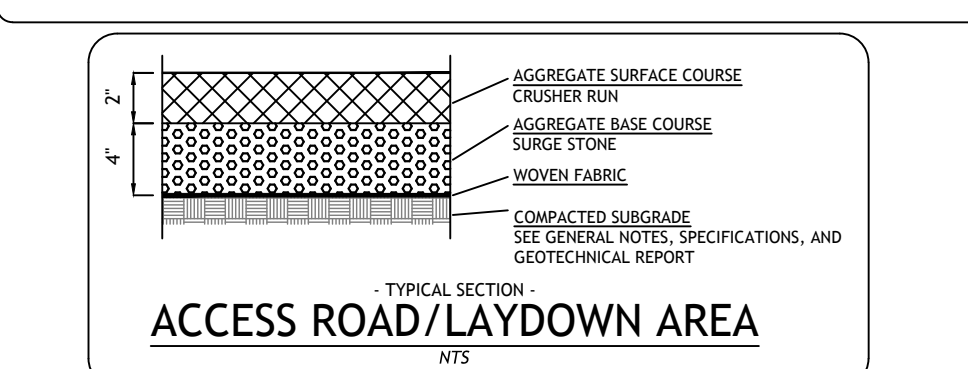

GENERAL EROSION CONTROL NOTE:
 ALL EROSION CONTROL MEASURES SHALL BE INSTALLED AND MAINTAINED PER N.C.D.E.N.R. BMP MANUAL. THE CONTRACTOR SHALL REFERENCE THE STORMWATER POLLUTION PREVENTION MANUAL (SWPPP) FOR ALL EROSION CONTROL PROCEDURES ON SITE.

NOTE:
 !! SKIMMER BASIN TO BE STABILIZED IMMEDIATELY AFTER INSTALLATION !!

NOTE:
 AS THE SURFACE RUNOFF PATTERN CHANGES DURING CONSTRUCTION, ADDITIONAL TEMPORARY DIVERSION DITCHES MAY BE NECESSARY TO DIRECT FLOW TO TEMPORARY SKIMMER BASIN.

DISTURBANCE NOTE:
 STABILIZATION MEASURES SHALL BE INITIATED AS SOON AS PRACTICABLE IN PORTIONS OF THE SITE WHERE CONSTRUCTION ACTIVITIES HAVE TEMPORARILY OR PERMANENTLY CEASED, BUT IN NO CASE MORE THAN FOURTEEN (14) DAYS AFTER WORK HAS CEASED.

NOTE:
 TEMPORARY CONSTRUCTION SIGNS SHALL NOT BE PLACED WITHIN THE ROAD RIGHT OF WAY OR SIGHT TRIANGLES.

- STORM DRAINAGE NOTES:**
1. PIPES ON-SITE AND WITHIN SCODOT RIGHT OF WAY HAVE BEEN DESIGNED FOR THE 10-YEAR STORM EVENT AT A 5 MIN. DURATION (INTENSITY = 6.7 IN/HR.)
 2. ALL PIPE WITHIN SCODOT RIGHT OF WAY TO BE REINFORCED CONCRETE PIPE (RCP).
 3. ALL PIPE JOINTS SHALL BE WRAPPED WITH A FILTER FABRIC IN 18-INCH WIDE SECTIONS UTILIZING, AT A MINIMUM, FABRIC WITH A MASS PER UNIT AREA OF (ENGLISH MEASURE) 5.0 OUNCES PER SQUARE YARD AND A THICKNESS OF 60 MILS - OR - (METRIC MEASURE) 170.0 GRAMS PER SQUARE METER AND A THICKNESS OF 1.5 MILLIMETERS.
 4. ALL PIPE LENGTHS SHOWN ON THE STORM DRAINAGE TABLE ARE APPROXIMATE. IT IS THE RESPONSIBILITY OF THE CONTRACTOR TO DETERMINE ACTUAL FIELD LENGTHS.
 5. ALL PIPES SHALL BE REINFORCED CONCRETE PIPE (RCP) PIPE, SEE SCHEDULE FOR CLASS INFORMATION.
 6. *DROP STRUCTURE INDICATED WHERE TWO (2) OR MORE PIPES DISCHARGE INTO SAME STRUCTURE AT DIFFERENT ELEVATIONS.

811
 Know what's below.
 Call before you dig.

DIGALERT

GRAPHIC SCALE
 (IN FEET)
 1 inch = 30 ft.

NAD 83 (2011)

Approved Construction Plan

Name	Date
Planning	
Traffic	
Fire	



Bluewater Civil Design, PLLC
 NC-P-0868

PLAN REVISION	ISSUE DATE	ISSUE COMMENT
A	2-3-2015	ISSUED FOR PERMITS

UTILITY PLAN
C301

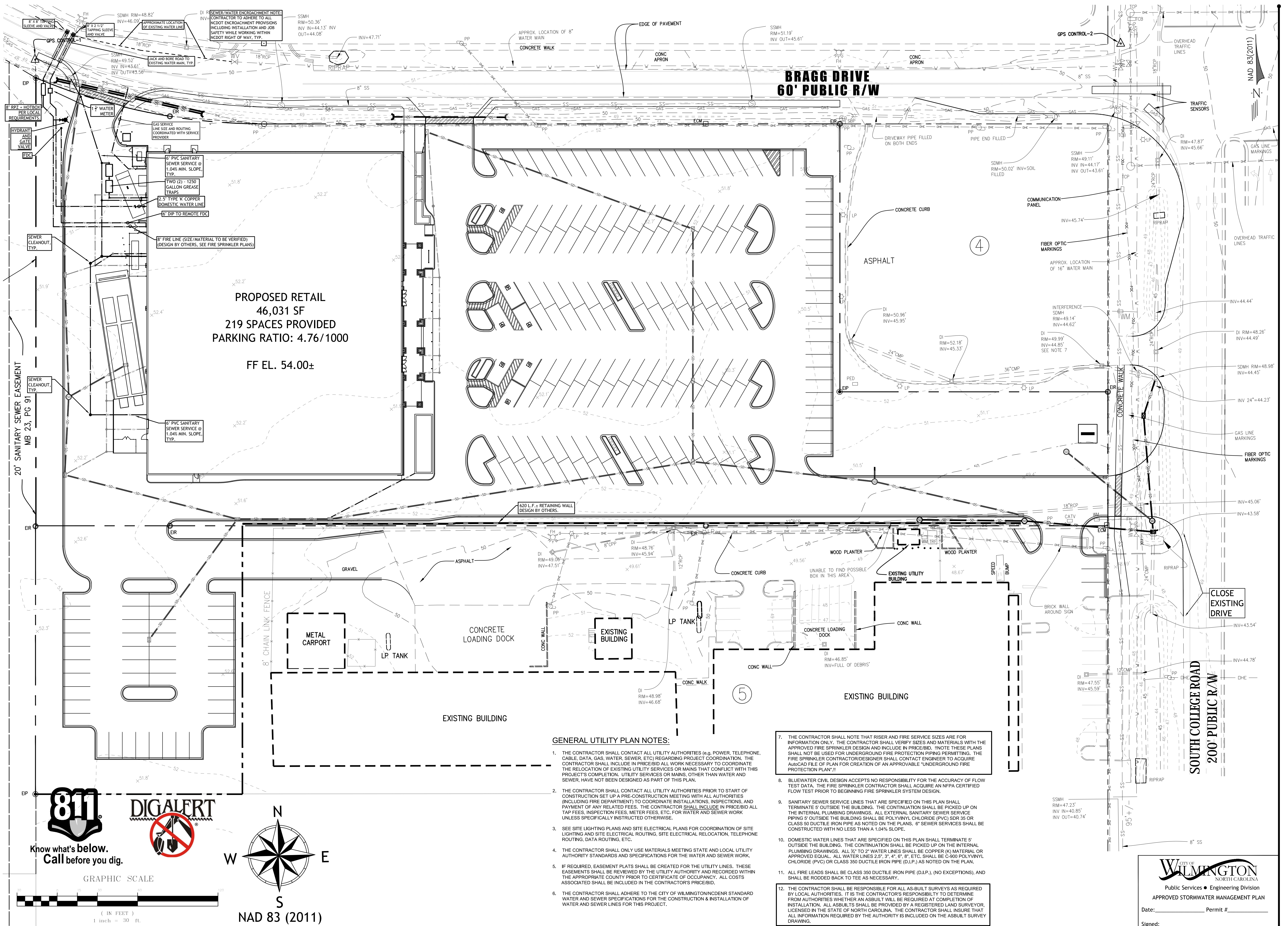

811 DIGALERT
 Know what's below. Call before you dig.
 GRAPHIC SCALE
 (IN FEET)
 1 inch = 30 FT.
 NAD 83 (2011)

GENERAL NOTES FOR SITEWORK

- The Contractor shall call 811 Utility Locate Service prior to start of any construction activity.
- Survey:
 - Survey Information provided by Robert Sessoms & Associates, PLLC (910-352-8846). The Contractor shall verify all benchmarks, easements, the location and invert elevation of all underground utilities within the construction area, verify property corners, and verify topography before any construction is begun.
 - The Contractor shall contact all utility companies prior to excavation to request a locate for all buried cables and underground utilities in the construction area or utilities that will be impacted by construction.
- Permits:
 - The Contractor shall have copies of any necessary encroachment and construction permits prior to entering any right-of-way or beginning construction.
 - Permits typically required include but are not limited to: State NPDES Coverage, Local Issuing Authority Grading Permit, DOT Encroachment Permits (Access and Utility taps), State or Local Water Authority water extension permit, State or Local Sewer Authority sewer extension permit, Fire Marshall approval, and Local Municipality Zoning and Site Plan Approval.
 - The Contractor shall immediately notify the Owner's Representative when notices or verbal instructions are received from regulatory authorities, inspectors, or similar. The Contractor shall proceed with work associated with such notices or instructions once approved to do so by the Owner's Representative or as required by law.
- Safety:
 - By Law, the Contractor shall comply with all OSHA regulations, including safety protocol, safety gear, safety education, etc.
 - The Contractor is exclusively responsible for the conditions of the site, including safety of all persons and property throughout the term of the project construction, 24 hrs per day / 7 days per week.
 - The Engineer's review of the Contractor's work product and performance will not include review of the Contractors safety programs. Such reviews are to be by OSHA inspectors and the Owner's Representative.
 - The Contractor is responsible for providing and maintaining all necessary traffic control devices during construction. Under no circumstances shall equipment be loaded or off-loaded on an open roadway. If such activity is required the Contractor shall coordinate shutting down the road with the appropriate DOT and utilize appropriate traffic control warning devices.
- SWPPP:
 - The Contractor is responsible for reviewing the requirements in the SWPPP drawings and maintaining all records as required by Local, State, and Federal Laws.
 - The SWPPP manual/plans shall be kept on-site in a secure location accessible to the inspector at all times during construction.
 - The Contractor shall post a 24-Hour Contact and phone # and rain gauge at the job site.
- Pre-construction Meeting:
 - The Contractor shall immediately contact the state or local issuing authority, utility companies, etc. and set up a pre-construction conference at the project location to discuss the requirements of the Geotechnical Engineer's report.
 - The Contractor shall make sure the Engineer of Record, Owner, Inspector, Superintendent, and any relevant erosion control sub-contractor are in attendance.
 - The Contractor shall develop an attendance sign in sheet and keep minutes of the meeting with the SWPPP.
- Tree Protection:
 - The Contractor shall protect trees that are noted to remain on the plans or as marked in the field by Owner's Representative. Trees that are to be protected shall have a protective fencing installed around the critical root zone (1' for every 1" DBH) and shall not disturb the root zone of such trees unless approved to do so in writing by the Owner's Representative.
 - The Contractor shall remove all trees and vegetation that interfere with new construction not noted to be protected. Remove debris from site or burn in accordance with local laws.
 - The Contractor shall be responsible for obtaining all necessary dumping or burning permits.
- Earthwork:
 - The Contractor shall grade the site to the lines and grades shown and shall proof-roll and test compaction on all areas.
 - The Contractor shall retain the services of a testing company to test all areas to insure they meet the minimum compaction requirements as noted in these notes or as required by the Owner's Geotechnical Engineer's report.
 - The Grading Contractor shall proof-roll the construction area. All soft spots shall be undercut and re-compacted with suitable structural fill material and re-tested. Proof-rolling shall be observed by a qualified Geotechnical Engineer or Engineering Technician.
 - All proposed elevations shown are finish grade elevation and the Grading Contractor shall deduct quantities from the finished grades as required due to depth of pavement sections, sidewalks, turf areas with topsoil, building foundations, etc. to develop the true finished sub-grade.
 - Any topsoil in the construction area shall be stripped to a depth as required (see Geotechnical Report for referenced depths) and stockpiled as directed by the Owner's Representative. Topsoil shall be re-used on-site unless approved otherwise.
 - The Contractor shall reference the Geotechnical Report for compaction requirements.
 - All excavation shall be "Classified Excavation". Excavation shall be "Classified" as "Common Excavation" or "Rock Excavation". **Rock Excavation** is removing material that has been observed by the testing company to only be removed by blasting or with an air hammer. **Common Excavation** is removing of materials by means of ripping and do not fall in the category of rock excavation as defined above (includes boulders, typically weathered rock, etc.)
 - The classification of soils include: topsoil, fill material, unsuitable material, and rock excavation. The classification of soils is the responsibility of the geotechnical soil testing firm.
 - Rock Excavation is classified as:
 - 8.9.A. Massive rock excavation - Material of 1 c.y., or more unable to be excavated with a single tooth ripper drawn by a crawler tractor having a minimum draw bar rated at not less than 53,000 pounds (Caterpillar D-8 or equivalent).
 - 8.9.B. Trench excavation - Material of 3/4 c.y. or more cannot be excavated with a power shovel having the capacity of at least that of a Caterpillar 225.
 - Fill material (including off site borrow) shall be from a source approved by the soil testing company and shall be free of roots, organics and boulders larger than 1 cubic foot. Fill shall be placed in 10" lifts and compacted as specified. The fill shall meet the specifications as required by the testing company or as indicated in the Geotechnical Report.
 - All existing paved areas to be removed shall be removed in 6" lifts and shall be replaced with a maximum 4" depth of compacted fill.
 - All slopes steeper than 4:1 receiving fill shall be plowed and scarified to enhance the bonding of new fill with existing surfaces.
 - The Grading Contractor shall include in contract price the total cost and unit price for all cut/fill necessary for earthwork balance including any necessary in-place or hauling of material.
 - The wetting/drying of soils to achieve specified compaction shall be included in the Grading Contractor's contract price.
 - All private roads and parking lots shall have a minimum 5'-0" wide grassed shoulder with a maximum 2.0% cross slope. All public roads shall have a 6'-0" wide grassed shoulder with a maximum 2.0% cross slope.
 - Tolerances for final constructed grades shall be plus or minus 0.05 feet. The final graded surface under all building slabs shall be within a tolerance of 3/8" when measured with a 10' straight edge. All designated ADA accessible paths shall have a maximum 2.00% (1:50) cross-slope and maximum 5.00% (1:20) running slope, no exceptions. All designated ADA accessible parking spaces and landings (including 4' area out from all doorways) shall have a maximum 2.00% (1:50) slope in any direction, no exceptions. All designated ADA accessible ramps shall have a maximum slope of 8.33% (1:12), no exceptions.
- Storm Drainage:
 - Reinforced Concrete Pipe (RCP) shall conform to ASTM C 76, latest edition. RCP with cover less than 15' and greater than 2' shall be CLASS II bell and spigot type and installed with flexible plastic (Bitumen) gaskets at all joints, unless otherwise noted. All other depths of cover shall be CLASS IV or V as noted. Gaskets shall comply with AASHTO M-198 751, Type B, and shall be installed in strict accordance with pipe manufacturer's recommendations.
 - All corrugated plastic pipe shall meet the requirements of AASHTO M-294, Type S, shall be smooth interior with annular corrugated exterior. HDPE, AD6, N-12, or approved equal. All joints shall be bell and spigot and shall meet the requirements of AASHTO M-294, shall be watertight, meeting the requirements of ASTM D 3212. The gaskets shall be made of Polyisoprene meeting the requirements of ASTM F 477. Installation shall conform to AASHTO M-294, ASTM D-2321, and manufacturer's installation procedures. The maximum cover allowed over the top of CCP is 15'.
- Utilities:
 - All water shall be per the approved drawing and the latest standards and specifications of the local water authority. The Contractor shall coordinate construction with the local water authority, including schedule & laydown areas. Any deviation from the approved plan shall be brought to the attention of the Engineer of Record and the appropriate inspector immediately. Deviations from the approved plan shall not be installed unless approved in writing by the local water authority.
 - Sanitary sewer lines and appurtenances shall be installed per the approved drawing and latest standards and specs of the local sewer authority.
 - The Contractor shall insure they have the proper approvals from the City of Wilmington & NCDENR prior to installation of any domestic water, fire water, or sanitary sewer system.
 - All utility trenches shall be thoroughly compacted as required by the local authority and tested to prevent settlement and damage to future pavement and structures.
 - The Contractor shall be responsible for relocating any existing utilities necessary for site construction, including all permits and fees. The Contractor is responsible for contacting all utility companies and including in his price all fees, charges, expenses, etc. in his cost to the Owner.
- Pavement:
 - All paving work (materials and construction) shall comply with NCDOT standards and specifications for Hot-mixed Asphalt Pavement. (See Pavement Section Details for depths of layers).
 - All pavement shall be installed on a finished and well-drained sub-grade compacted as specified in previous notes.
 - Base course material for asphalt pavement shall be stone aggregate base course (ABC) and compacted to 100% modified proctor.
 - Concrete pavement shall consist of a base course with stone aggregate base course compacted to 100% modified proctor. The concrete shall be poured with WWF. Concrete shall be broom finished and jointed as required.
 - Concrete curb and gutter ON-SITE AND OUTSIDE OF NCDOT RIGHT OF WAY shall be per ON-SITE 24" Curb and Gutter per City of Wilmington Standards.
 - Concrete curb and gutter WITHIN NCDOT RIGHT OF WAY shall be NCDOT STANDARD 30" wide with standard curb constructed with 4,000 PSI concrete with expansion joints and contraction joints installed to comply with state DOT standard specification for materials and construction of curb and gutter.
 - All parking lot striping shall be per State D.O.T. specifications with two (2) coats of paint applied. The bases of all light poles, all bollards, and the face of all sidewalks, are to be painted **TRAFFIC YELLOW**. The Contractor is responsible for providing fire lane striping and signage meeting all local requirements. Parking lot striping shall be reflective paint (see site plan for color). Stop bars, directional arrows, and parcel pickup are to be reflective paint (see site plan for color). All ADA striping shall be reflective ADA blue.
- Erosion Control and Drainage:
 - All areas outside paving limits and building foundations shall have a minimum 4" layer of topsoil added and permanently grassed in accordance with state seeding specifications or landscaped per the Landscape Plan if applicable.
 - The Grading Contractor shall maintain positive drainage away from buildings at all times. The Contractor shall bring to the attention of the Engineer any areas that may not drain properly during construction.
 - The sequence of work shall conform to the erosion control narrative.
 - Sediment controls during construction shall comply with all local, state, and federal laws and regulations. After all sitework is completed and grassing established, the Grading Contractor shall remove all silt from the site and legally dispose of all silt off-site at no additional cost to the Owner, or bury on-site in non-structural area.
 - No work shall begin on site until approval from the City of Wilmington & New Hanover County, a NCDENR NPDES permit has been issued, and a pre-construction meeting has been completed with the City of Wilmington, the Owner, and the Engineer.
- General:
 - The Contractor shall review the plans and specifications carefully and shall immediately notify the Engineer for a review if any discrepancies are discovered at the site or on the drawings.
 - All reference to state standards and specifications are made from the North Carolina Department of Transportation Standard Specifications for Roads and Bridges, latest edition and Roadway Standard Drawings, latest edition.
 - Dimensions shown on the drawings are measured as shown on outside face of building wall or face of curb line, unless otherwise noted. Curb and Gutter is shown as three (3) lines (outside edge of gutter, face of curb, and back of curb).
 - All retaining wall design shall be per Architectural Plan or separate Structural Engineer's design notes and details. The Civil Plans shall not be considered plans for retaining wall construction.
 - The General Contractor is responsible for posting all required bonds that General Contractors are allowed to post.
 - If any conflicts between the notes, details, specifications, and drawings occur then by rule the stricter shall govern.

STANDARD EROSION AND SEDIMENT CONTROL NOTES

Startup

- Sediment and erosion control devices shall be installed and functioning prior to beginning any project earth disturbing activities.
- Soil stabilization shall be achieved on any area of a site where land-disturbing activities have temporarily or permanently ceased according to the following schedule:
 - All perimeter dikes, swales, ditches, perimeter slopes and all slopes steeper than 3 horizontal to 1 vertical (3:1) shall be provided temporary or permanent stabilization with ground cover as soon as practicable but in any event within 7 calendar days from the last land-disturbing activity.
 - All other disturbed areas shall be provided temporary or permanent stabilization with ground cover as soon as practicable but in any event within 14 calendar days from the last land-disturbing activity.
- To secure the project site, locate limits of construction, protect areas that are to remain undisturbed, and prevent migration of construction debris, orange construction fencing shall be installed around areas not requiring silt fencing. Any accumulation of construction debris on public roadways or adjacent properties shall be removed within 24 hours. Care shall be taken when installing construction fencing to not obscure oncoming traffic at intersections, adjacent driveways and the project construction entrance.

Inspections and Maintenance

- All sediment and erosion control devices shall be inspected every seven (7) days minimum or after every rain event. Damaged or ineffective devices shall be repaired or replaced, as necessary.
- All sediment and erosion controls shall be inspected, at the specified inspection frequency, until construction is complete and the site is permanently stabilized.
- All erosion control devices shall be properly maintained during all phases of construction until the completion of all construction activities and all disturbed areas have been permanently stabilized. Additional control devices may be required during construction in order to control erosion and/or offsite sedimentation. All temporary control devices shall be removed once construction is complete and the site is permanently stabilized.

Best Management Practices (BMPs)

- A stabilized construction entrance shall be installed and maintained on the project site. Storm water inlet protection shall be provided for all inlets (upstream and downstream) within 50 ft. of the construction entrance (on both sides of the public roadway).
- During the course of construction activities erosion and sediment controls shall be used to prevent sediment accumulation on public roadways (including street gutters), sediment laden runoff from entering into existing storm water system inlets or depositing on adjacent properties, and airborne dust migration off-site. Any accumulation of sediment from the project site on public roadways or adjacent properties shall be removed within 24 hours.

or

The contractor must take necessary action to minimize the tracking of mud onto the paved roadway construction areas. The contractor shall daily remove mud/soil from pavement, as may be required.

- Provide silt fence and/or other control devices, as may be required, to control soil erosion during utility construction. All disturbed areas shall be cleaned, graded, and stabilized immediately after the utility installation.
- Silt fencing shall be placed no closer than 5 ft. downhill from the toe of any fill area.
- Temporary stockpiling of useable or waste materials for more than fourteen (14) days shall have appropriate erosion and sediment control measures installed. Temporary stockpiles shall be placed away from storm water inlet structures, adjacent property and public roadways.
- Litter, construction debris, oils, fuels, building products with significant potential for impact (such as stockpiles of freshly treated lumber), and construction chemicals that could be exposed to storm water must be prevented from becoming a pollutant source in storm water discharges.
- Temporary diversion berms and/or ditches will be provided as needed during construction to protect areas from upslope runoff and/or to divert sediment laden water to appropriate traps or stable outlets.
- If necessary, slopes which exceed eight (8) vertical feet should be stabilized with synthetic or vegetative mats, in addition to hydro seeding. It may be necessary to install temporary slope drains during construction. Temporary berms may be needed until the slope is brought to grade.
- Cat track or surface roughening is required for all slopes greater than 4:1 prior to seeding and lying of synthetic or vegetative mats. Cat tracking or surface roughening shall produce a surface with furrows running cross slope, parallel with slope contours, and perpendicular to surface runoff.

Close-out

- The site shall be considered permanently stabilized when all surface disturbing activities are complete and either of the two following criteria are met:
 - A uniform (e.g., evenly disturbed, without large bare areas) perennial vegetative cover with a density of 70% of the native background vegetative cover for the area has been established on all unupaved areas and areas not covered by permanent structures, or
 - Equivalent permanent stabilization measures (such as riprap, gabions, or geotextiles) have been employed.
- Upon completion of construction activities and meeting the conditions of permanent stabilization a Notice of Termination (NOT) shall be submitted to N.C.D.E.N.R. Wilmington Regional Office and a copy of the submitted NOT shall be sent to the City of Wilmington and New Hanover County.

ENVIRONMENTAL / GEOTECHNICAL NOTE:
Per the Geotechnical Report - Soils at the site are moisture sensitive, therefore, construction schedule (season) is important. Demolition Debris may be present to varying degrees across the site and undercutting of existing soils may be required. Contractor to carefully review the Environmental and Geotechnical reports as part of this project. Contractor to adhere to the requirements in the reports. Monitoring wells may be removed/relocated/installed as part of this project, Contractor to coordinate with Geotech Engineer regarding installation/location/procedure/schedule, etc.

ENVIRONMENTAL: Limited Environmental Site Assessment Prepared by: Commonwealth Environmental Associates, Inc. Iron Bridge Rd. Richmond, VA 23237 Project # 8414

GEOTECHNICAL: Geotechnical Engineering Report Prepared by: Terracon Consultants, Inc. 2401 Brentwood Road, Suite 107 Raleigh, NC 27604 Report # 70145126

NCDENR - SEDIMENT CONTROL NOTES

Ground Stabilization

- Soil stabilization shall be achieved on any area of a site where land-disturbing activities have temporarily or permanently ceased according to the following schedule:
 - All perimeter dikes, swales, ditches, perimeter slopes and all slopes steeper than 3 horizontal to 1 vertical (3:1) shall be provided temporary or permanent stabilization with ground cover as soon as practicable but in any event within 7 calendar days from the last land-disturbing activity.
 - All other disturbed areas shall be provided temporary or permanent stabilization with ground cover as soon as practicable but in any event within 14 calendar days from the last land-disturbing activity.

- Conditions - In meeting the stabilization requirements above, the following conditions or exemptions shall apply:
 - Extensions of time may be approved by the permitting authority based on weather or other site-specific conditions that make compliance impracticable.
 - All slopes 50' in length or greater shall apply the ground cover within 7 days except when the slope is flatter than 4: 1. Slopes less than 50' shall apply ground cover within 14 days except when slopes are steeper than 3:1, the 7 day-requirement applies.
 - Any sloped area flatter than 4: 1 shall be exempt from the 7-day ground cover requirement.
 - Slopes 10' or less in length shall be exempt from the 7-day ground cover requirement except when the slope is steeper than 2: 1.
 - Although stabilization is usually specified as ground cover, other methods, such as chemical stabilization, may be allowed on a case-by-case basis.
 - For portions of projects within the Sediment Control Commission-defined "High Quality Water Zone" (I5A NCAC 04A.0105), stabilization with ground cover shall be achieved as soon as practicable but in any event on all areas of the site within 7 calendar days from the last land disturbing act.
 - Portions of a site that are lower in elevation than adjacent discharge locations and are not expected to discharge during construction may be exempt from the temporary ground cover requirements if identified on the approved E&S Plan or added by the permitting authority.

Self Inspection and Reporting Requirements
Minimum self inspection and reporting requirements are as follows unless otherwise approved in writing by the Division of Water Quality.

- A rain gauge shall be maintained in good working order on the site unless another rain monitoring device has been approved by the Division of Water Quality.
- A written record of the daily rainfall amounts shall be retained and all records shall be made available to Division of Water Quality or authorized agent upon request. If no daily rain gauge observations are made during weekend or holiday periods, and no individual-day rainfall information is available, the cumulative rain measurement for those un-attended days will determine if a site inspection is needed. (Note: if no rainfall occurred, the permittee must record "zero").
- Erosion and sedimentation control measures shall be inspected to ensure that they are operating correctly. Inspection records must be maintained for each inspection event and for each measure. At a minimum, inspection of measures must occur at the frequency indicated below:
 - All erosion and sedimentation control measures must be inspected by or under the direction of the permittee at least once every seven calendar days, and
 - All erosion and sediment control measures must be inspected by or under the direction of the permittee within 24 hours after any storm event of greater than 0.50 inches of rain per 24 hour period.
- Once land disturbance has begun on the site, stormwater runoff discharge outfalls shall be inspected by observation for erosion, sedimentation and other storm water discharge characteristics such as clarity, floating solids, and oil sheens. Inspections of the outfalls shall be made at least once every seven calendar days and within 24 hours after any storm event of greater than 0.50 inches of rain per 24 hour period.
- Inspections are only required to be made during normal business hours. When adverse weather conditions would cause the safety of the inspection personnel to be in jeopardy, the inspection can be delayed until it is deemed safe to perform these duties. (Times when inspections were delayed because of safety issues should be noted in the Inspection Record.) If the inspection cannot be done on that day, it must be completed on the following business day.
- Twenty-four Hour Reporting for visible sediment deposition
 - The permittee shall report to the Division of Water Quality central office or the appropriate regional office any visible sediment being deposited in any stream or wetland or any noncompliance which may endanger health or the environment. (See Section VIII of this permit for contact information.) Any information shall be provided orally or electronically within 24 hours from the time the permittee became aware of the circumstances.
 - A written submission shall be provided to the appropriate regional office of the Division of Water Quality within 5 days of the time the permittee becomes aware of the circumstances. The written submission shall contain a description of the sediment deposition and actions taken to address the cause of the deposition. The Division of Water Quality staff may waive the requirement for a written report on a case-by-case basis.

- Records of inspections made during the previous 30 days shall remain on the site and available for agency inspectors at all times during normal working hours, unless the Division of Water Quality provides a site-specific exemption based on unique site conditions that make this requirement not practical. Older records must be maintained for a period of three years after project completion and made available upon request. The records must provide the details of each inspection including observations, and actions taken in accordance with this permit. The permittee shall record the required rainfall and monitoring observations on the Inspection Record form provided by the Division or a similar inspection form that is inclusive of all of the elements contained in the Division's form. Use of electronically-available records, in lieu of the required paper copies for inspection will be allowed if shown to provide equal access and utility as the hard-copy records.

- Inspection records must include, at a minimum, the following:
 - Control Measure Inspections: Inspection records must include at a minimum:
 - 1) identification of the measures inspected,
 - 2) date and time of the inspection,
 - 3) name of the person performing the inspection,
 - 4) indication of whether the measures were operating properly,
 - 5) description of maintenance needs for the measure,
 - 6) corrective actions take, and
 - 7) date of actions taken, as well as the date and amounts of rainfall received.
 - Stormwater Discharge Inspections: Inspection records must include at a minimum:
 - 1) identification of the discharge outfall inspected,
 - 2) date and time of the inspection,
 - 3) name of the person performing the inspection,
 - 4) evidence of indicators of stormwater pollution such as oil sheen, floating or suspended solids or discoloration,
 - 5) indication of visible sediment leaving the site,
 - 6) actions taken to correct/prevent sedimentation, and
 - 7) date of actions taken.
 - Visible Sedimentation Found Outside the Site Limits: Inspection records must include:
 - 1) an explanation as to the actions taken to control future releases,
 - 2) actions taken to clean up or stabilize the sediment that has left the site limits, and
 - 3) the date of actions taken.
 - Visible Sedimentation Found in Streams or Wetlands: All inspections shall include evaluation of streams or wetlands onsite or offsite (where accessible) to determine if visible sedimentation has occurred.
- Visible Stream Turbidity - If the discharge from a site results in an increase in visible stream turbidity, inspection records must record that evidence and actions taken to reduce sediment contributions. Sites discharging to streams named on the state's 303(d) list as impaired for sediment-related causes may be required to perform additional monitoring, inspections or application of more-stringent management practices if it is determined that the additional requirements are needed to assure compliance with the federal or state impaired-waters conditions. If a discharge covered by this permit enters a stream segment that is listed on the Impaired Stream List for sediment-related causes, and a Total Maximum Daily Load (TMDL) has been prepared for those pollutants, the permittee must implement measures to ensure that the discharge of pollutants from the site is consistent with the assumptions and meets the requirements of the approved TMDL. The Division of Water Quality 303(d) list can be found at: http://h2o.enr.state.nc.us/tmdl/General_303d.htm/

EROSION CONTROL NOTES

SITE INFORMATION:

- Existing Condition: Undeveloped, Wooded Site
 - Proposed Condition: COMMERCIAL USE - PAVEMENT & BUILDING
 - Proposed Work: EXCAVATION & FILLING
 - Existing Soils: Le (Leon Sand), Ly (Lynn Haven fine Sand), Mu (Murville fine sand)
- BMPs Shown on Plan: INLET PROTECTION, SILT FENCE, SKIMMER BASIN, CHECK DAMS, CONSTRUCTION ENTRANCE
- Disturbed Area: 6.00+ ACRES FOR RE-DEVELOPMENT

EROSION CONTROL SEQUENCE (for Contractor):

Phase I - Sheet C202:

- Schedule a Pre-Construction Meeting at the site with the Owner, Engineer, and any local inspectors at least 72 hrs prior to commencement of construction.
- Install the permit box on-site.
- Clearly mark the limits of disturbance.
- Install construction entrance, install BMPs, and install any perimeter silt fence BMP protection prior to demolition activities.
- Establish main Construction Entrance/ Exit during demolition off Bragg Dr.
- Contractor to obtain all required demolition permit prior to beginning demolition (city of Wilmington, CFPWA, utilities/duke energy/tree removal, etc.).
- Continuously maintain all BMPs throughout construction. Remove accumulated sediment from BMPs and clean-out Sediment Basins as noted on plans. NOTE: Contractor's price for work shall be all inclusive for installing and maintaining BMPs as shown on drawings.

Note:

Maintenance of Sediment and Erosion Control Measures must continue until the site is permanently stabilized until the controls are removed.

Phase II-A - Sheet C203:

- Install Skimmer Sediment Basin 1 and required storm drainage as indicated on sheet C203.
- Install dewatering diversion ditches and direct stormwater runoff to skimmer sediment basin 1.
- Begin topsoil stripping as noted. Topsoil shall be re-used in grass or landscape areas and on slopes after rough grading operations.
- Construct Building Laydown area and Staging area around the proposed building pad.
- Continuously maintain all BMPs throughout construction. Remove accumulated sediment from BMPs and clean-out Sediment Basin as noted on plans. NOTE: Contractor's price for work shall be all inclusive for installing and maintaining BMPs as shown drawings.

Phase II-B - Sheet C204:

- Inspect and maintain sediment basin 1 (Constructed in Phase II).
- Install storm drainage, utilities, etc. as grade allows.
- Install Hardware Cloth & Gravel Inlet protection at all catch basins as they are constructed.
- Install temporary ditches/swales to divert stormwater to catch basins as shown on sheets C203.
- Install rock check dams as soon as ditch/swale grades are reached.
- Begin Rough Grading. Temporary or Permanent grassing shall be established on areas disturbed with no activity for 7 days. Continuously remove accumulated silt/sediment from BMPs.
- Install Retaining Walls (See design by geotechnical engineer).
- Install Slope Matting on all slopes 3:1 or steeper.
- Install Rip Rap Aprons in sediment pond #1 immediately as the corresponding headwalls are installed.
- Continuously maintain all BMPs throughout construction. Remove accumulated sediment from BMPs and clean-out Sediment Basin as noted on plans. NOTE: Contractor's price for work shall be all inclusive for installing and maintaining BMPs as shown drawings.

Phase III - Sheet C205:

- Inspect and maintain sediment basin 1 (Constructed in Phase II).
- Finalize Fine Grading and construct curb & gutter.
- Place stone as soon as possible on all areas to be paved and building pads.
- Respread topsoil (4" min.), evenly on unimproved areas and areas with no impervious surfaces proposed including all slopes.
- Place slope matting (Tensar RECP per detail) on all slopes as noted on the Phase III Erosion Control Plan.
- Permanently grass all areas not to be paved or built upon (ie outpads) or that receives landscaping/mulch. Establish 100% coverage with 70% density.
- Finalize all paving and grassing to achieve final stabilization.
- Remove silt/sediment from all BMPs (including sediment pond #1) and dispose of legally or on-site as approved by the soil testing company.
- Construct WET POND BMP.
- Once site is finalized with 100% grass coverage and 70% density contact local inspector and Engineer of Record for closeout inspection.
- Address any punchlist items from closeout inspection.
- Remove temporary BMPs once site is accepted for closeout by local issuing authority.
- Contact Engineer and schedule final walkthrough. Engineer will coordinate with Owner to apply for NOT (Stormwater).

CONTRACTOR TO PERFORM SELF INSPECTION ON ALL SEDIMENT AND EROSION CONTROL MEASURES AFTER EACH PHASE OF CONSTRUCTION TO ENSURE THE EROSION CONTROL & SEDIMENTATION PLANS ARE BEING FOLLOWED. COMPLETE THE SELF-INSPECTION REPORT (OBTAIN FROM NCDENR WEBSITE) AND PROVIDE TO OWNER AND ENGINEER.



Know what's below.
Call before you dig.

WILMINGTON
NORTH CAROLINA
Public Services • Engineering Division
APPROVED STORMWATER MANAGEMENT PLAN
Date: _____ Permit # _____
Signed: _____

Project Number: 2014-090
DWG Name: 2014-090 Details.dwg
Drawing Scale: AS NOTED
Date of Project: 10-21-2014
Engineer of Record:
Jason Henderson, P.E.
South Carolina PEF 2296
Georgia PEF 02071
North Carolina PEF 031306
Alabama PEF 32054
info@bluewatercivil.com
www.bluewatercivil.com

bluewater **civil design, PLLC**
19 Washington Park Suite 100 • Greenville, SC 29601
www.bluewatercivil.com • info@bluewatercivil.com

Certificates of Authorization:
SC 02412 - GA PE005865
NC P0868 - AL CA40056

Bragg Road Dev. Company, LLC
Bragg Drive
Wilmington, NC

Approved Construction Plan
Name _____
Date _____
Planning _____
Traffic _____
Fire _____

WILMINGTON
PROFESSIONAL ENGINEER
23 2015
No. 031306
PAUL HENDERSON

Bluewater Civil Design, PLLC
NC-P-0688

PLAN REVISION	ISSUE DATE	ISSUE COMMENT
A	2-3-2015	ISSUED FOR PERMITS

NOTES & DETAILS

C501

Approved Construction Plan
 Name _____ Date _____
 Planning _____
 Traffic _____
 Fire _____

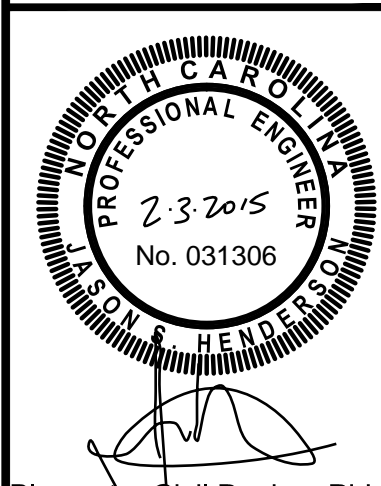

Bluewater Civil Design, PLLC
 NC-P-0868

PLAN REVISION	ISSUE DATE	ISSUE COMMENT
A	2-3-2015	ISSUED FOR PERMITS
---	---	---
---	---	---
---	---	---
---	---	---
---	---	---
---	---	---
---	---	---
---	---	---

NOTES & DETAILS

C502

SECTION 2930 – SEEDING AND LANDSCAPING

1.1 INTRODUCTION
 This section covers the furnishing of all labor, equipment, material and any other items necessary for landscaping of all areas of the site disturbed by construction operations and all earth surfaces including rough and fine grading, topsoil if required, fertilizer, lime, seeding and mulching. The Contractor shall adapt his operations to variations in weather or soil conditions as necessary for successful establishment and growth of grasses or legumes.

1.2 CATALOG CUT SUBMITTALS
 Contractor shall submit 4 copies of catalog cuts to Engineer for review for all materials that are required to complete the work as described in the associated plans. Engineer will retain two sets of original submittals and return two sets to the Contractor with the appropriate response annotated.

1.3 STORAGE AND HANDLING
 Contractor shall take all prudent and customary measures to ensure that all materials stay moisture free and are not degraded by storage or handling. All lime and fertilizer shall be kept free from hardening or caking and if this occurs they shall be pulverized to their original state. All seed shall be further protected such that it is not subjected to heat or rodents. If degradation occurs and the materials no longer hold the mineral values advertised then they shall be removed from the site and new materials applied.

1.4 MATERIALS
A. Lime
 The quality of lime and all operations in connection with the furnishing of this material shall comply with the requirements of the North Carolina Lime Law and regulations adopted by the NC- Board of Agriculture.
 Lime shall be agriculture grade ground dolomite limestone. It shall contain not less than 85% of the calcium and magnesium carbonates and shall be of such fineness that at least 90% will pass a No. 10 sieve and at least 50% will pass a No. 100 sieve.

B. Fertilizer
 The quality of fertilizer and all operations in connection with the furnishing of this material shall comply with the requirements of the North Carolina Fertilizer Law and regulations adopted by the NC- Board of Agriculture.
 Fertilizer shall be 10-10-10 grades. Upon written approval of the Engineer a different grade of fertilizer may be used, provided the rate of application is adjusted to provide the same amounts of plant food.

Section 2930-1

1.5 PREPERATION
A. Protection of Existing Vegetation
 The Contractor shall not remove or damage vegetation, which is outside the Clearing Limits established by the Owner/Engineer or as displayed on the plans. All trees that are damaged and scheduled to remain shall be repaired in an acceptable manner promptly to prevent progressive deterioration. Vegetation which is scheduled to be replaced or is damaged beyond repair during construction operations shall be replaced with a similar size and species. Where this is not feasible the property owner shall be compensated for the vegetation damaged. Damage incurred during construction operations and due to insufficient protection shall be paid at the Contractors expense.
 Existing vegetation not indicated for removal shall be protected against unnecessary cutting, breaking or skimming of roots, skinning or bruising of bark or smothering of vegetation by placing stockpiles of excavated material against the trunk or excessively over roots within the drip line. Vegetation shall also be protected against excessive vehicle or foot traffic within the drip line.
 Roots cut during excavation shall be properly protected by either asphalt sealing or in some cases wrapping exposed roots in wet burlap to prevent drying.

B. Grading
 Rough grading of the area shall be achieved as soon as the excavated area is backfilled and compacted. Rough grading shall be defined as all material restored which is required to bring the area to finish grade and acceptable surface drainage for storm water which provides for water to flow from the site in such a manner as that it does not place unusual risk to unsuspecting users of adjacent areas or inhabitants.
 Fine grading of the area shall be achieved in a timely manner after completion of rough grading of the area. Fine grading shall consist of shaping final contours to ensure proper drainage and removing all debris or construction waste materials to provide an acceptable appearance. Construction area subject to finish grading shall have soil loosened to a depth of not less than 6 inches in a manner approved by the Engineer to promote seed growth. All finish landscaping shall be completed on a section-by-section basis where it is reasonable to expect completion of landscaping.
 All grading, landscaping, and erosion control measures shall be properly pursued and maintained in order to maintain and acceptable appearance of the project. If such time occurs as this perception is degraded then the Engineer may suspend progress on the project until the issues are appropriately addressed.

Section 2930-3

C. Surface and Bed Preparation
 The Contractor shall smooth or shape surface contours outside the project site when such contours are detrimental to the seedbed preparation or will pose foreseeable problems with future maintenance of the area. The Engineer shall direct the Contractor to what extent outside areas shall be affected or the Contractor may elect to work with individual property owners with written verification delivered to the Engineer/Owner of the agreement with the property owner's signature.
1.c Level Areas and Slopes Less than 2:1
 The construction area shall have soil loosened to a depth not less than 6 inches and shall be free from all debris, clods and all other irregularities which would prohibit a smooth, shaped finish grade. Top 3 inches of soil shall be worked to a clod free finish suitable for planting seed.
2.c Slopes Greater Than 2:1
 The construction area shall have soil loosened and acceptable for vegetation growth but the surface shall be free from all debris, clods and other irregularities. The surface may be track finished, scarified, grooved or punctured so as to provide a place for seed and other planting material to lodge. In the case of such slopes the Engineer may allow partial completion of the slope sections at different times to promote stabilization. If the vegetation growth is acceptable the Engineer may allow this to remain as the permanent ground cover.
 The Contractor shall not pursue the finished preparation of surface areas to be landscaped if the soil is frozen, marginally wet or when the Engineer deems it unsuitable for working conditions.

D. Rate of Application
 Seed shall be applied by means of Broadcast Spreader, Hydro-Seeder or other previously approved method. In no case shall seed, lime, or fertilizer be spread by hand. The rates of application for seed, lime and fertilizer shall be as follows, unless a variance is permitted by the Engineer in writing prior to performing work.
1.d Limestone
 In the absence of a soil test performed at the Contractors expense and given to the Engineer on letterhead from the testing laboratory, Limestone shall be applied at the rate of 2000 lb/ acre.

Section 2930-4

2.d Fertilizer
 In the absence of a soil test performed at the Contractors expense and given to the Engineer on letterhead from the testing laboratory, Fertilizer shall be applied at the rate of 1000 lb/ acre. Fertilizer shall be 10-10-10 grade, unless a variance is permitted by the Engineer in writing prior to performing work. A second application at 500-lb/ acre shall be applied to the area when the grass has reached a blade height of 3 inches or 45 days which ever comes first.

3.d Seed
 The type and rate of application shall vary at different times of the year and shall be applied at the rate and type appropriate for the time of year. All rates of application are measured in pounds per acre.
a. Fall and Winter (Sept. 1 to May 1)
 85 pounds of Ky-31 tall fescue mixed with 15 pounds of rye grain.
b. Spring and Summer (May 1 to September 1)
 100 pounds of Ky-31 tall fescue mixed with 10 pounds of rye grain.
c. Cut of Fill slopes greater than 2:1
 The application rate on cut or fill slopes greater than 2:1 shall include the appropriate mix above for the time of year along with; 40 lb/acre of sericea lespedeza (hulled in spring or summer and unhulled in fall and winter) and either 15 pounds of Sudan grass in spring and summer or 25 pounds of rye cereal per acre in fall and winter.

4.d Mulch
 Mulch shall be straw mulch applied at a rate of approximately 3000 pounds per acre. Straw shall be applied at such rate necessary to thoroughly cover and protect all finish grading, seed, lime and fertilizer but not smother the maturation of seed.

E. Application
 Application of all limestone, fertilizer, seed and mulch shall be completed immediately following final preparation of the seed bed and shall not be pursued during a time when the Engineer deems weather to be non-conducive for seed growth, i.e. ground wet, frozen, etc. Lime, fertilizer and seed shall be distributed uniformly over the prepared seedbed at the specific rate of application and then harrowed, raked, or otherwise thoroughly worked or mixed into the seedbed. Immediately following the covering operation, the seedbed shall be properly compacted as directed in the manner and degree approved by the Engineer.

Section 2930-5

NEW HANOVER COUNTY BMP MAINTENANCE NOTES:

- Maintenance Plan**
- All erosion and sediment control measures will be checked for stability and operation following every runoff-producing rainfall, but in no case, less than once every week and within 24 hours of every half inch rainfall.
 - All points of egress will have construction entrances that will be periodically top-dressed with an additional 2 inches of #4 stone to maintain proper depth. They will be maintained in a condition to prevent mud or sediment from leaving the site. Immediately remove objectionable material spilled washed or tracked onto the construction entrance or roadways.
 - Sediment will be removed from hardware cloth and gravel inlet protection, block and gravel inlet protection, rock doughnut inlet protection and rock pipe inlet protection when the designed storage capacity has been half filled with sediment. Rock will be cleaned or replaced when the sediment pool no longer drains as designed. Debris will be removed from the rock and hardware cloth to allow proper drainage. Silt sacks will be emptied once a week and after every rain event. Sediment will be removed from around beaver dams, dandy sacks and socks once a week and after every rain event.
 - Diversion ditches will be cleaned out immediately to remove sediment or obstructions from the flow area. The diversion ridges will also be repaired. Swales must be temporarily stabilized within 21 calendar days of cease of any phase of activity associated with a swale.
 - Sediment will be removed from behind the sediment fence when it becomes half filled. The sediment fence will be repaired as necessary to maintain a barrier. Stakes must be steel. Stake spacing will be 6 feet max. with the use of extra strength fabric, without wire backing. Stake spacing will be 8 feet max. when standard strength fabric and wire backing are used. If rock filters are designed at low points in the sediment fence the rock will be repaired or replaced if it becomes half full of sediment, no longer drains as designed or is damaged.
 - Sediment will be removed from sediment traps when the designed storage capacity has been half filled with sediment. The rock will be cleaned or replaced when the sediment pool no longer drains or when the rock is dislodged. Baffles will be repaired or replaced if they collapse, tear, decompose or become ineffective. They will be replaced promptly. Sediment will be removed from baffles when deposits reach half the height of the 1st baffle. Floating skimmers will be inspected weekly and will be kept clean.
 - All seeded areas will be fertilized, reseeded as necessary and mulched according to specifications in the vegetative plan to maintain a vigorous, dense vegetative cover. All slopes will be stabilized within 21 calendar days. All other areas will be stabilized within 15 working days.
 - Flocculants will be used to address turbidity issues. The pumps, tanks, hoses and injection systems will be checked for problems or turbid discharges daily.

TEMPORARY AND PERMANENT SEEDING NOTES

- The Contractor shall follow the "Supplemental Technical Specification Z-3" except for any specification on payment or submittals to the Resident Construction Engineer (RCE). The Engineer of Record or Owner's Representative shall be substituted for the RCE.
- All disturbed areas not receiving pavement, mulch, or landscaping shall be permanently grassed per these specifications.
- All disturbed areas with no activity for more than 14 days shall be temporarily grassed per these specifications.
- The Contractor shall include in his contract price to the Owner all costs necessary to permanently grass the site meeting the definition of "stabilized" as defined by the NPDES General Permit (100% coverage and 70% density) or as may be required by the local issuing authority if stricter. It is the Contractor's responsibility to know these requirements and estimate the cost to meet these requirements.
- All topsoil stripped from the site shall be spread over areas to be grassed and landscaped to a uniform depth as to use all native topsoil.

Section 2930-6

When a hydraulic seeder is used for application of seed and fertilizer, the seed shall not remain in water containing fertilizer for more than 1 hour prior to application unless otherwise permitted by the Engineer.
 The Engineer may permit modifications to the requirements for covering or compacting lime, fertilizer and seed in the prepared seedbed if the Contractor requests modification due to height, steepness of slope or non-conductive soil conditions. Modifications may be considered if the case of: Slopes greater than 2:1 and Slopes where surface is to rocky to successfully permit compaction or covering of the seedbed. Modifications may be permitted to include reduction of application rates and reduction or elimination of compaction requirements.
 All equipment normal and prudent for the preparation of seedbed and uniform distribution of lime, fertilizer and seed shall be approved by the Engineer prior to use on the project. In the event of malfunctioning or improperly maintained equipment, the Engineer reserves the right to suspend work on the project until such time as the equipment is restored to good repair and properly operational.

F. Mulching
 Mulch shall be spread uniformly over all seeded areas at a rate of 1 1/2 to 2 tons per acre in a continuous, uniform blanket. Mulch shall be spread by hand or by approved mechanical shredder or blower which will provide a uniform blanket. An acceptable application shall be one that completely covers the ground but still allows some sunlight to penetrate and air to circulate while providing effective soil moisture conservation and reduced erosion. Mulching operation shall be pursued immediately following final seedbed preparation.
 Tack or other approved binding material shall be applied over top of mulch in all necessary areas to ensure mulch will be held in place during adverse conditions. The rate and method of application shall be completed as directed by the Engineer.
 The Contractor shall implement sufficient precautions to prevent mulch from entering drainage structures through displacement by wind, water or other causes. The Contractor shall remove completely any blockage to drainage structures, which may occur.

G. Maintenance
 Grassed areas shall be accepted when a 95% cover of permanent grasses is achieved and weeds are not the dominant foliage. The Contractor shall keep all grassed areas in good condition, reseeding and mowing if and when necessary as directed by the Engineer. A good lawn shall be established over the entire project area and shall be maintained by the Contractor in an approved manner and kept in an approved condition until final acceptance.

Section 2930-6

Section 2930-7

CITY OF WILMINGTON
 NORTH CAROLINA
 Public Services • Engineering Division
 APPROVED STORMWATER MANAGEMENT PLAN
 Date: _____ Permit # _____
 Signed: _____

Approved Construction Plan
 Name _____ Date _____
 Planning _____
 Traffic _____
 Fire _____

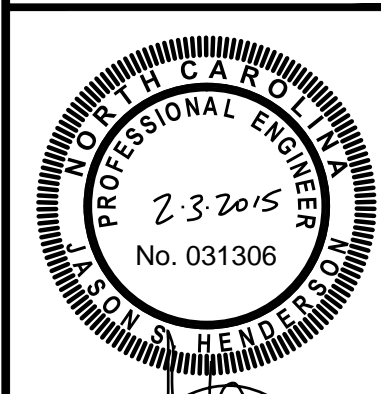

Bluewater Civil Design, PLLC
 NC-P-0868

PLAN REVISION	ISSUE DATE	ISSUE COMMENT
A	2-3-2015	ISSUED FOR PERMITS

NOTES & DETAILS

C503

- GENERAL NOTES:**
- UNIFORMLY GRADE A SHALLOW DEPRESSION APPROACHING THE INLET.
 - DRIVE 6-FOOT STEEL POSTS 2 FEET INTO THE GROUND SURROUNDING THE INLET. SPACE POSTS EQUALLY AROUND THE PERIMETER OF THE INLET, A MAXIMUM OF 4 FEET APART.
 - SURROUND THE POSTS WITH WIRE MESH HARDWARE CLOTH. SECURE THE WIRE MESH TO THE STEEL POSTS AT THE TOP, MIDDLE, AND BOTTOM. PLACE A 2-FOOT FLAP OF THE WIRE MESH UNDER THE GRAVEL FOR ANCHORING IS RECOMMENDED.
 - PLACE CLEAN GRAVEL (NO DOT #5 OR #57 STONE) ON A 2:1 SLOPE WITH A HEIGHT OF 18 INCHES AROUND THE WIRE, AND SMOOTH TO AN EVEN GRADE.
 - ONCE THE CONTRIBUTING DRAINAGE AREA HAS BEEN STABILIZED, REMOVE ACCUMULATED SEDIMENT, AND ESTABLISH FINAL GRADING ELEVATIONS.
 - COMPACT THE AREA PROPERLY AND STABILIZE IT WITH GROUND COVER.

MAINTENANCE:
 Inspect inlets at least weekly and after each significant (1/2 inch or greater) rainfall event. Clear the mesh wire of any debris or other objects to provide adequate flow for subsequent rains. Take care not to damage or undercut the wire mesh during sediment removal. Replace stone as needed.

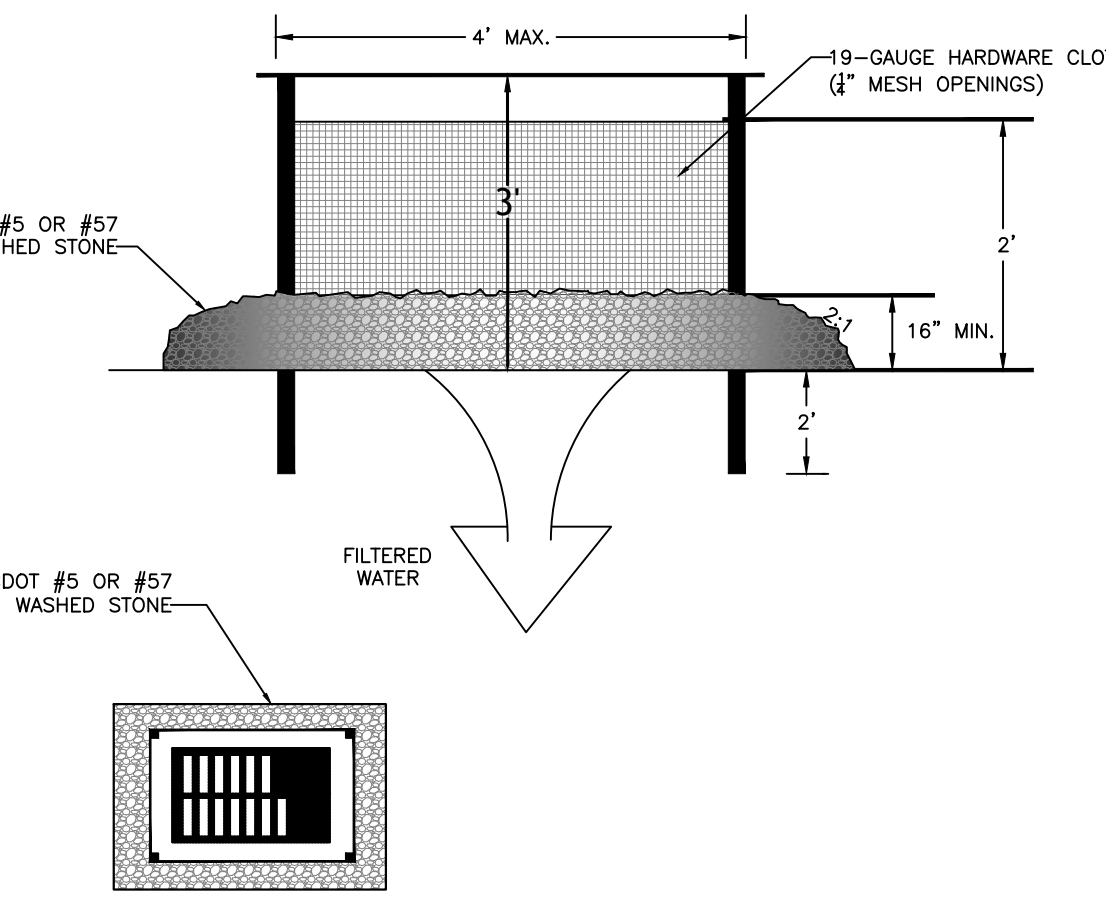

HARDWARE CLOTH AND GRAVEL INLET PROTECTION

NOT TO SCALE

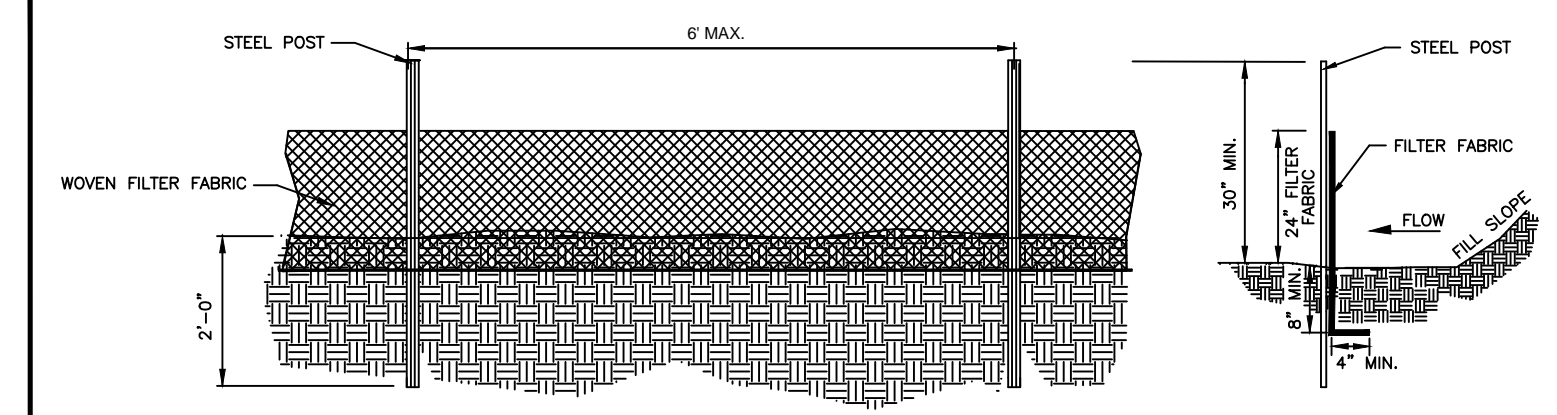

- GENERAL NOTES:**
- WOVEN FILTER FABRIC BE USED WHERE SILT FENCE IS TO REMAIN FOR A PERIOD OF MORE THAN 30 DAYS.
 - STEEL POSTS SHALL BE 5'-0" IN HEIGHT AND BE OF THE SELF-FASTENER ANGLE STEEL TYPE.
 - TURN SILT FENCE UP SLOPE AT ENDS.
 - ORANGE SAFETY FENCE IS REQUIRED AT BACK OF SILT FENCE WHEN GRADING IS ADJACENT TO SWIM BUFFERS, STREAMS OR WETLANDS. (REFER TO SWIM BUFFER GUIDELINES). THE COLOR ORANGE IS RESERVED FOR VISUAL IDENTIFICATION OF ENVIRONMENTALLY SENSITIVE AREAS.
 - DRAINAGE AREA CAN NOT BE GREATER THAN 1/4 ACRE PER 100 FT OF FENCE.
 - SLOPE LENGTHS CAN NOT EXCEED CRITERIA SHOWN IN TABLE 6.62A NORTH CAROLINA EROSION AND SEDIMENT CONTROL PLANNING AND DESIGN MANUAL.
 - DO NOT INSTALL SEDIMENT FENCE ACROSS STREAMS, DITCHES, WATERWAYS OR OTHER AREAS OF CONCENTRATED FLOW.

- MAINTENANCE NOTES:**
- FILTER BARRIERS SHALL BE INSPECTED BY THE FINANCIALLY RESPONSIBLE PARTY OR HIS AGENT IMMEDIATELY AFTER EACH RAINFALL AND AT LEAST DAILY DURING PROLONGED RAINFALL. ANY REPAIRS NEEDED SHALL BE MADE IMMEDIATELY.
 - SHOULD THE FABRIC DECOMPOSE OR BECOME INEFFECTIVE PRIOR TO THE END OF THE EXPECTED USABLE LIFE AND THE BARRIER STILL IS NECESSARY, THE FABRIC SHALL BE REPLACED PROMPTLY.
 - SEDIMENT DEPOSITS SHOULD BE REMOVED WHEN DEPOSITS REACH APPROX. HALF THE HEIGHT OF THE BARRIER. ANY SEDIMENT DEPOSITS REMAINING IN PLACE AFTER THE SILT FENCE IS REMOVED SHALL BE DRESSED TO CONFORM TO THE EXISTING GRADE, PREPARED AND SEEDED.

TEMPORARY SILT FENCE

NOT TO SCALE

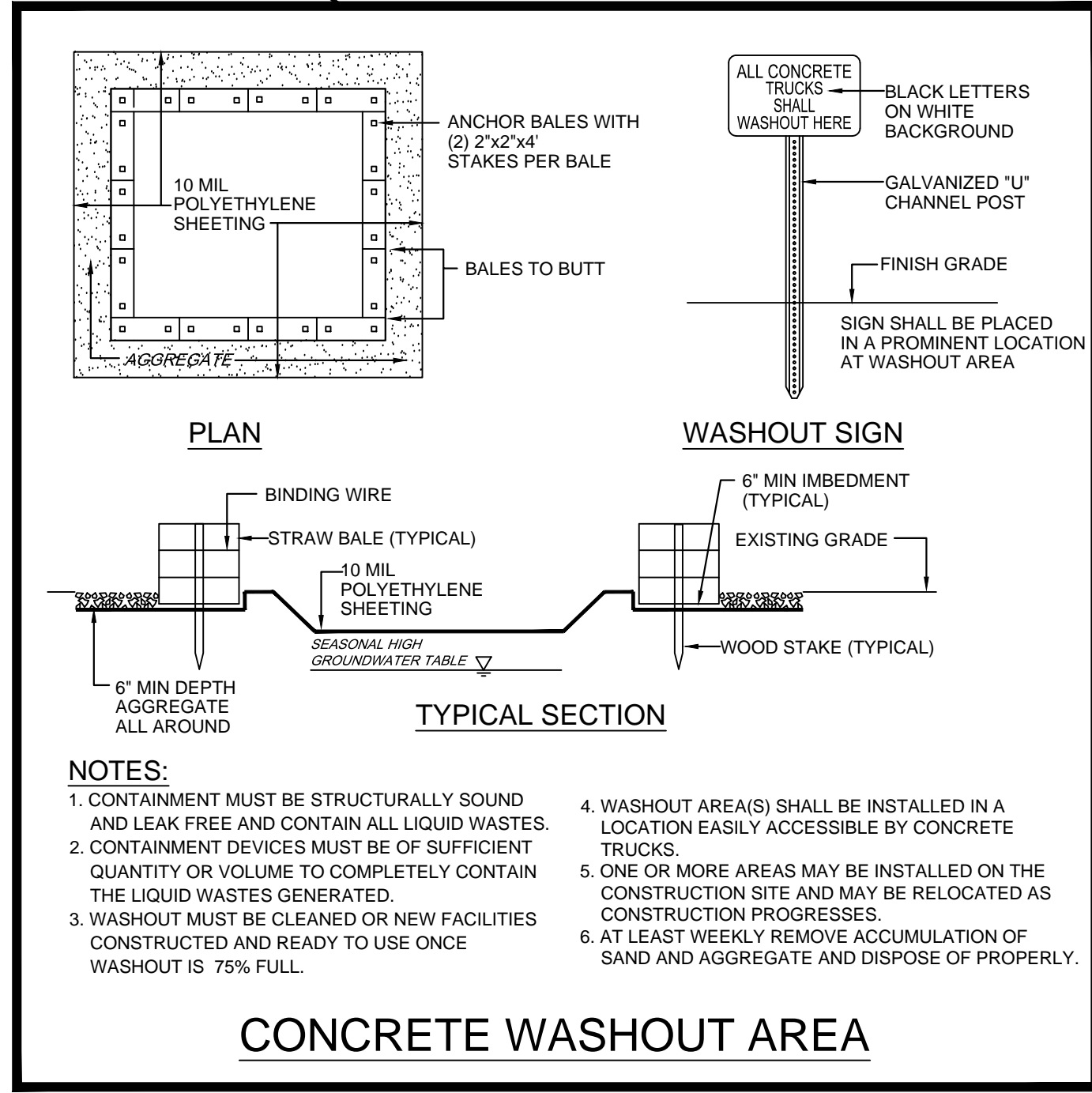

CONCRETE WASHOUT AREA

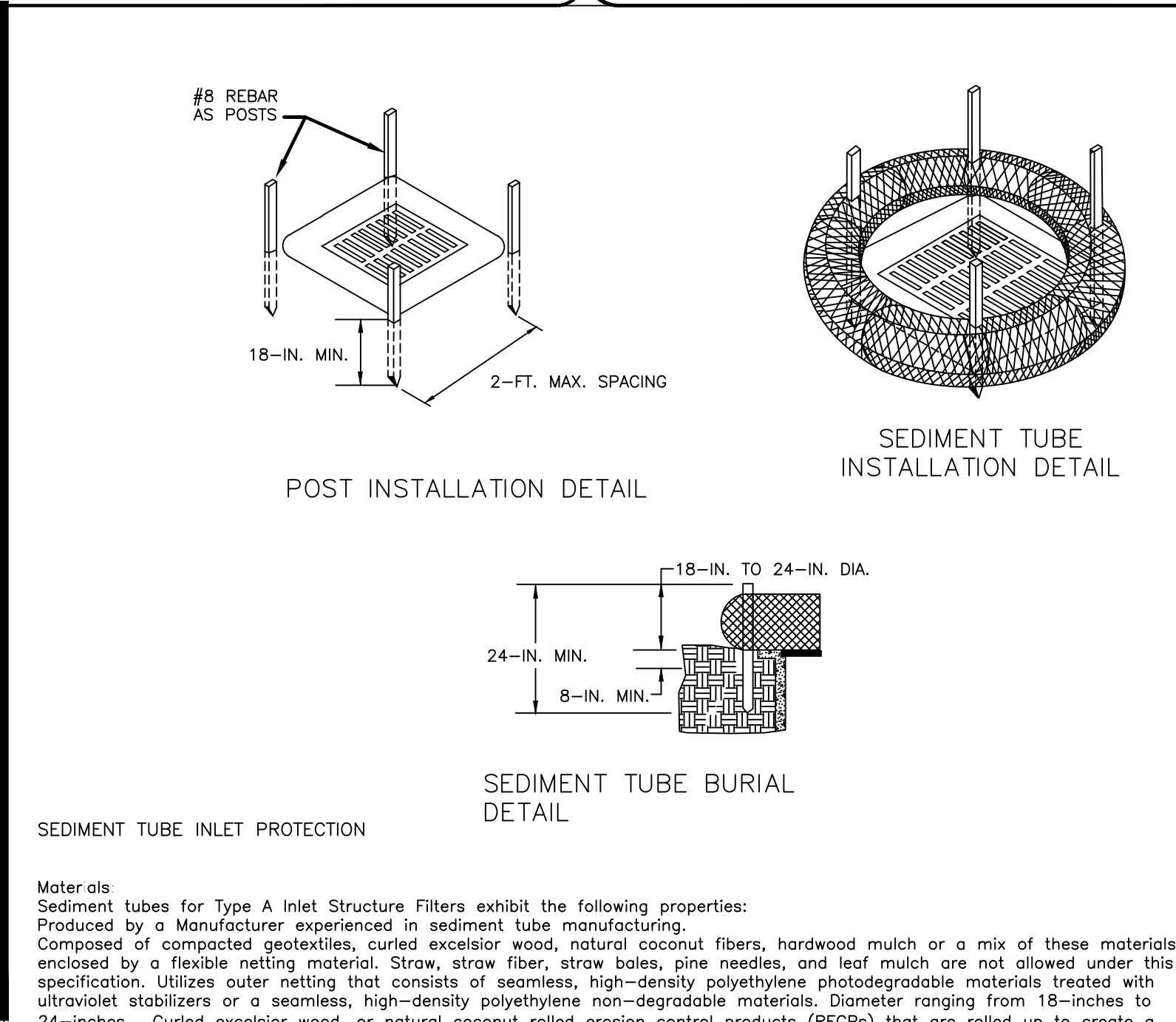

SEDIMENT TUBE INLET PROTECTION

Materials
 Sediment tubes for Type A Inlet Structure Filters exhibit the following properties:
 Produced by a Manufacturer experienced in sediment tube manufacturing.
 Composed of compacted geotextiles, curled excelsior wood, natural coconut fibers, hardwood mulch or a mix of these materials enclosed by a flexible netting material. Straw, straw fiber, straw bales, pine needles, and leaf mulch are not allowed under this specification. Utilizes outer netting that consists of seamless, high-density polyethylene photodegradable materials treated with ultraviolet stabilizers or a seamless, high-density polyethylene non-degradable materials. Diameter ranging from 18-inches to 24-inches. Curled excelsior wood, or natural coconut rolled erosion control products (RECPs) that are rolled up to create a sediment tube are not allowed under this specification. Select applicable Sediment Tubes from the SCDOT approved products list.

Use #8 REBAR posts that meet the following minimum physical requirements:

Installation:
 Remove all rocks, clods, vegetation or other obstructions so installed sediment tubes have direct contact with the underlying soil or surface. Install sediment tubes by laying them flat on the ground. Construct a small trench to a depth that is 20% of the sediment tube diameter. Lay the sediment tube in the trench and compact the upstream sediment tube soil interface. Do not completely bury sediment tubes during installation. Lap the ends of adjacent sediment tubes a minimum of 6-inches to prevent flow and sediment from passing through the field joint. Never stack sediment tubes on top of one another. Install sediment tubes using REBAR stakes a minimum of 48-inches in length placed on 2-foot centers. Intertwine the stakes with the outer mesh on the downstream side, and drive the stakes in the ground to a minimum depth of 24-inches leaving with 12-inches of stake above the exposed sediment tube.

Inspection and Maintenance:
 Inspect every seven calendar days and within 24-hours after each rainfall event that produces 1/2-inches or more of precipitation. Inspect sediment tubes after installation for gaps under the tubes and for gaps between joints of adjacent ends of sediment tubes. Repair rills, gullies, and all undercutting near sediment tubes. Remove and/or replace installed sediment tubes as required to adapt to changing construction site conditions. Remove all sediment tubes from the site when the functional longevity is exceeded as determined by the Engineer, Inspector or Manufacturer's Representative. Dispose of sediment tubes in regular means as non-hazardous, inert material.

TEMPORARY GRAVEL CONSTRUCTION ENTRANCE/EXIT

Definition A graveled area or pad located at points where vehicles enter and leave a construction site.

Purpose To provide a buffer area where vehicles can drop their mud and sediment to avoid transporting it onto public roads, to control erosion from surface runoff, and to help control dust.

Conditions Where Practice Applies Whenever traffic will be leaving a construction site and moving directly onto a public road or other paved off-site area. Construction plans should limit traffic to properly constructed entrances.

Design Criteria
Aggregate Size—Use 2-3 inch washed stone.
Dimensions of gravel pad—
 Thickness: 6 inches minimum
 Width: 12-foot minimum or full width at all points of the vehicular entrance and exit area, whichever is greater
 Length: 50-foot minimum
Location—Locate construction entrances and exits to limit sediment from leaving the site and to provide for maximum utility by all construction vehicles (Figure 6.06a). Avoid steep grades, and entrances at curves in public roads.

Washing—If conditions at the site are such that most of the mud and sediment are not removed by vehicles traveling over the gravel, the tires should be washed. Washing should be done on an area stabilized with crushed stone that drains into a sediment trap or other suitable disposal area. A wash rack may also be used to make washing more convenient and effective.

Construction Specifications

- Clear the entrance and exit area of all vegetation, roots, and other objectionable material and properly grade it.
- Place the gravel to the specific grade and dimensions shown on the plans, and smooth it.
- Provide drainage to carry water to a sediment trap or other suitable outlet.
- Use geotextile fabrics because they improve stability of the foundation in locations subject to seepage or high water table.

Maintenance Maintain the gravel pad in a condition to prevent mud or sediment from leaving the construction site. This may require periodic treading with 2-inch stone. After each rainfall, inspect any structure used to trap sediment and clean it out as necessary. Immediately remove all objectionable materials spilled, washed, or tracked onto public roadways.

References
Runoff Conveyance Measures
 6.30, Grass-lined Channels
Sediment Traps and Barriers
 6.60, Temporary Sediment Trap

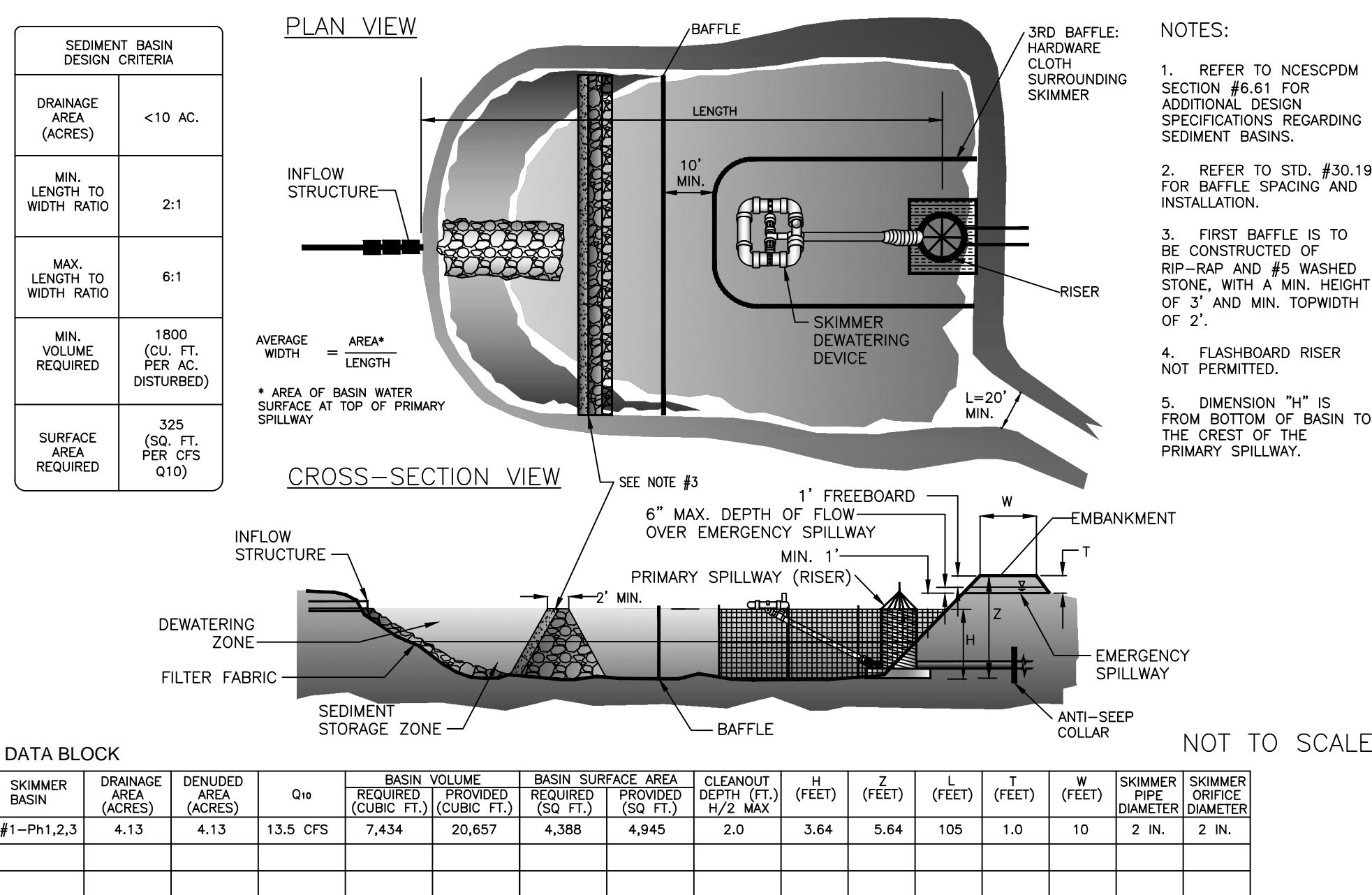

SKIMMER SEDIMENT BASIN

GENERAL NOTES:

- AREA UNDER EMBANKMENT SHALL BE CLEARED, GRUBBED, AND STRIPPED OF ANY VEGETATION AND ROOT MATERIAL. THE BASIN AREA SHALL BE CLEARED.
- THE FILL MATERIAL FOR THE EMBANKMENT SHALL BE FREE OF ROOTS OR OTHER WOODY VEGETATION AS WELL AS OVERSIZED STONES, ROCKS, ORGANIC MATERIAL OR OTHER OBJECTIONABLE MATERIAL. THE EMBANKMENT SHALL BE COMPACTED BY TRAVERSING WITH EQUIPMENT WHILE BEING CONSTRUCTED. SPILLWAYS SHOULD NOT BE CONSTRUCTED THROUGH FILL SECTIONS. ALL SPILLWAYS SHOULD BE LINED AND/OR RIPRAPPED.
- SEDIMENT SHALL BE REMOVED AND TRAP RESTORED TO ITS ORIGINAL DIMENSIONS WHEN THE SEDIMENT HAS ACCUMULATED TO DEPTH SHOWN ON STANDARD. REMOVED SEDIMENT SHALL BE DEPOSITED IN A SUITABLE AREA IN SUCH A MANNER THAT IT WILL NOT ERODE.
- THE TRAP SHALL BE INSPECTED AFTER EACH RAIN AND REPAIRS MADE AS NECESSARY.
- CONSTRUCTION OPERATION SHALL BE CARRIED OUT IN SUCH A MANNER THAT EROSION AND WATER POLLUTION IS MINIMIZED.
- ALL CUT AND FILL SLOPES SHALL BE 2:1 OR FLATTER, UNLESS CERTIFIED BY REGISTERED GEOTECHNICAL ENGINEER.
- SEDIMENT BASIN EMBANKMENTS SHOULD BE PROVIDED WITH EROSION CONTROL AND STABILIZATION.
- STORAGE AREA MAY BE CONSTRUCTED IN ANY SHAPE PROVIDED THE MINIMUM STORAGE VOLUME REQUIREMENT IS MET. THE BASIN SHOULD ALSO BE ORIENTED SUCH THAT THE FILTER AND THE MAIN FLOW OF WATER AND SEDIMENT ARE ON OPPOSITE ENDS ON THE LONGER BASIN DIMENSIONS.
- THE LENGTH OF THE STONE OUTLET (SPILLWAY) IS TO BE BASED ON A 10 YEAR STORM.
- WHENEVER TOPOGRAPHY ALLOWS, THE BASIN LENGTH SHOULD BE TWICE (2X) THE BASIN WIDTH, TO ALLOW FOR SETTLING. BAFFLES SHALL BE INSTALLED IN ALL BASINS.
- CLEANOUT STAKES SHALL BE PLACED IN ALL SEDIMENT BASINS AT THE LOW POINT IN THE BASIN. THE STAKES SHALL BE MARKED SHOWING THE HALF FULL, CLEANOUT POINT, OF THE BASIN.
- SAFETY FENCING 3' HIGH SHOULD BE PLACED AROUND ALL SEDIMENT BASINS.
- FOR DESIGN OF SEDIMENT BASINS, REFER TO THE NORTH CAROLINA DEPARTMENT OF ENVIRONMENT AND NATURAL RESOURCES, EROSION AND SEDIMENT CONTROL PLANNING AND DESIGN MANUAL.
- FOR SLOPES GREATER THAN 10° IN LENGTH AND PROTECTED BY SILT FENCE AT THE TOE OF THE SLOPE, SLOPE TERRACING WILL BE REQUIRED.
- THE BERM ON SEDIMENT BASINS SHALL BE SEEDED ONCE FINAL GRADE HAS BEEN REACHED. THE SILT FENCE MAY BE REMOVED IF PERMISSION HAS BEEN GRANTED BY THE CITY LAND DEVELOPMENT INSPECTOR AFTER THE GRASS HAS GERMINATED AND STABLE GROUND HAS BEEN ESTABLISHED.
- WASHED STONE AND WIRE BACKING SHALL BE USED WITH SILT FENCE WHENEVER SILT FENCE IS PLACED AT THE TOE OF A SLOPE >10° VERTICAL OR ALONG ANY CHANNEL OR WATER COURSE WHERE 50' OF BUFFER IS NOT PROVIDED.

GENERAL NOTES—SEDIMENT BASINS

STD. & SPEC. #	TITLE	SPECIAL REQUIREMENTS & NOTES
6.17	ROLLED EROSION CONTROL PRODUCTS	---
6.51	HARDWARE CLOTH & GRAVEL INLET PROTECTION	---
6.60	TEMPORARY SEDIMENT TRAP	WEIR TOP WIDTH 10' MIN., BOTTOM 7' MIN.
6.61	SEDIMENT BASIN	FLASH BOARD RISER NOT PERMITTED
6.64	SKIMMER SEDIMENT BASIN	1ST BAFFLE: RIP RAP & WASHED STONE BERM 2ND BAFFLE: STANDARD BAFFLE 3RD BAFFLE: HARDWARE CLOTH SURROUNDING THE SKIMMER

THE STANDARDS & SPECIFICATIONS SHOWN ARE FROM THE "NORTH CAROLINA EROSION AND SEDIMENT CONTROL PLANNING AND DESIGN MANUAL" (NCESCPDM) PREPARED BY NC DEPT. OF ENVIRONMENT AND NATURAL RESOURCES (NC DENR).

SPECIAL EROSION CONTROL REQUIREMENTS & NOTES

GENERAL NOTES:

- RIPRAP SIZE TO BE DESIGNED BY ENGINEER.
- CHECK DAMS MAY BE USED IN SLOPING DITCHES OR CHANNELS TO SLOW VELOCITY OR TO CREATE SEDIMENT TRAPS.
- ENSURE THAT MAXIMUM SPACING BETWEEN DAMS PLACES THE TOE OF THE UPSTREAM DAM AT THE SAME ELEVATION AS THE DOWNSTREAM DAM (SEE DIAGRAM BELOW).

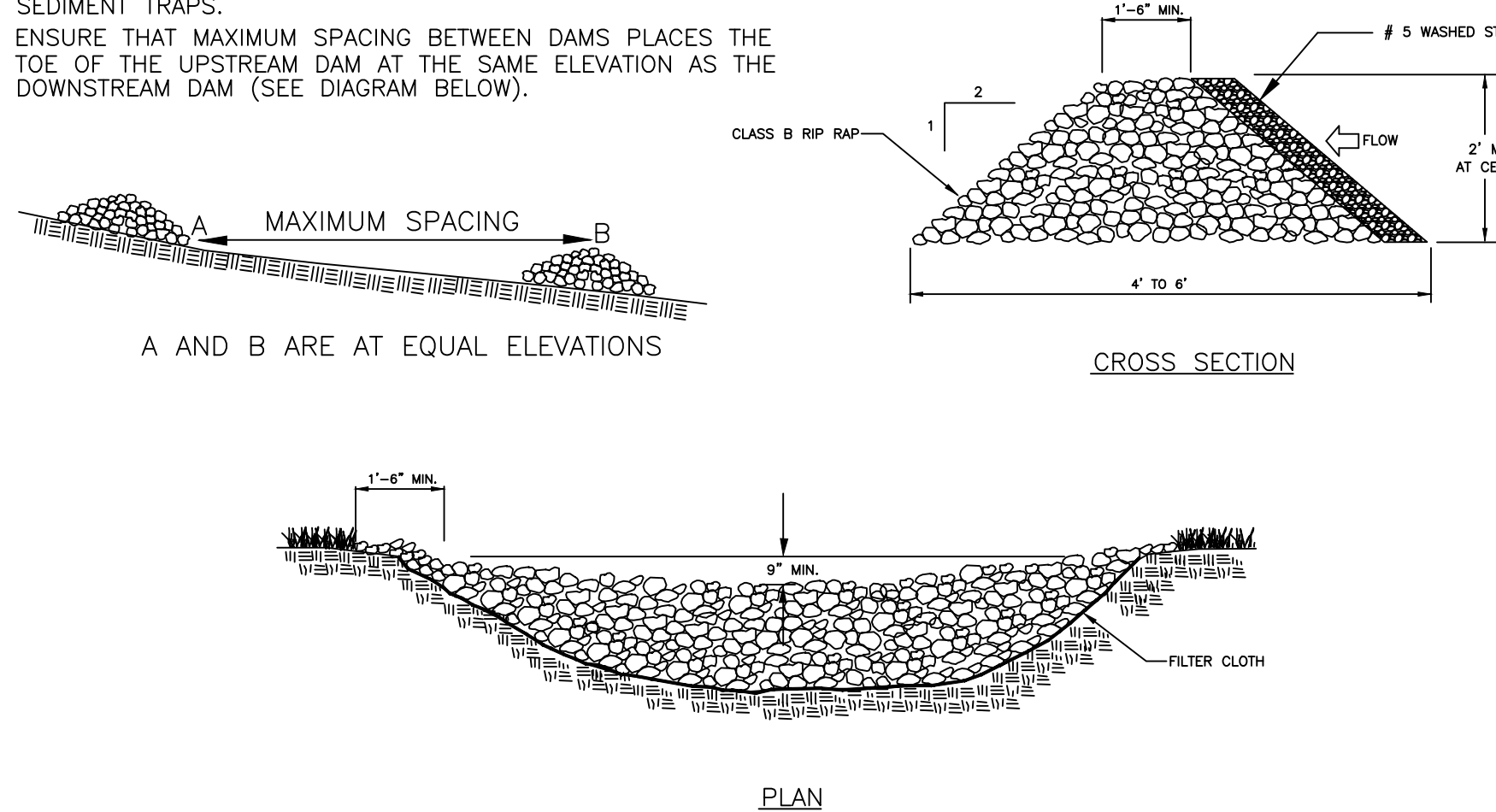

TEMPORARY ROCK CHECK DAM

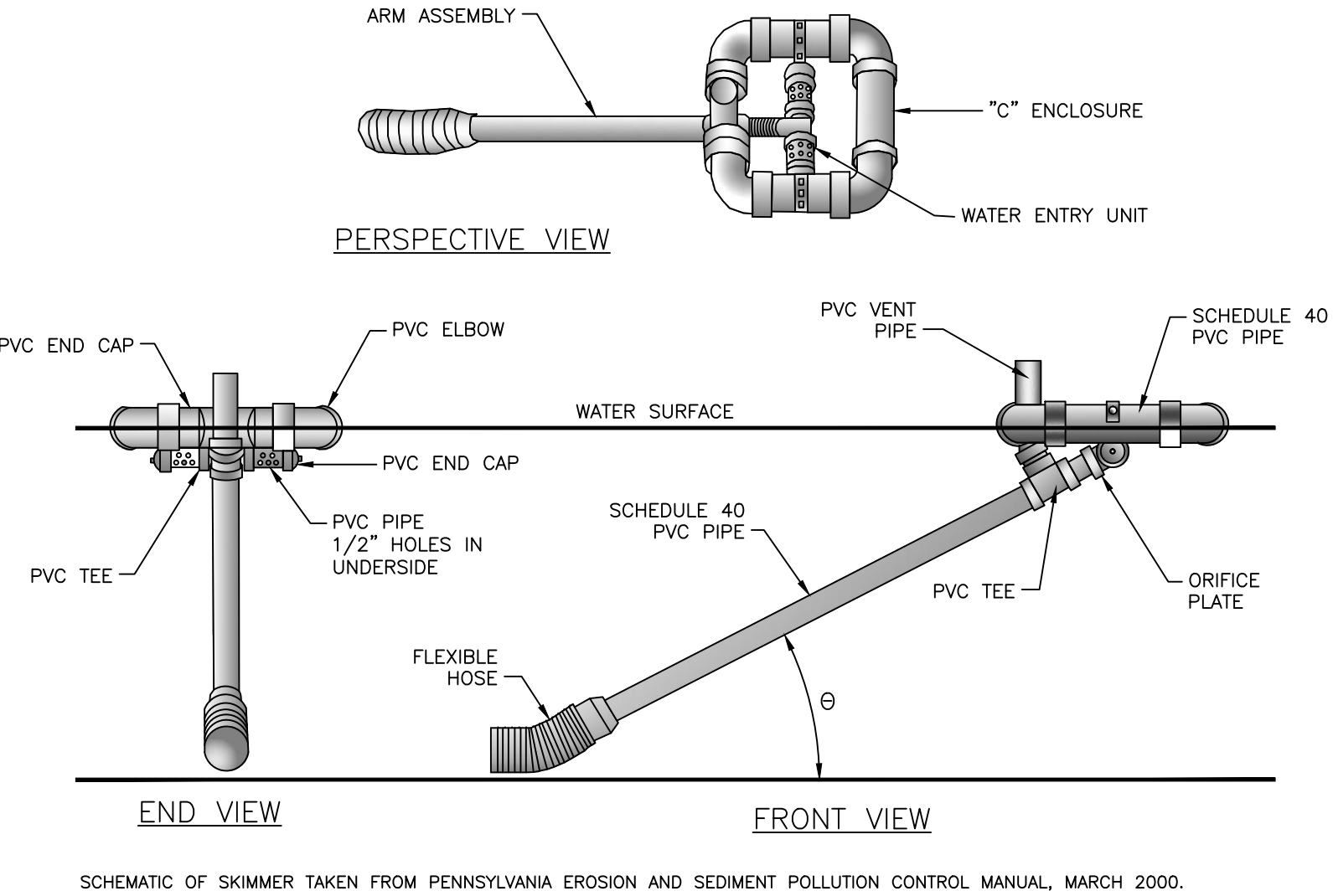

SKIMMER

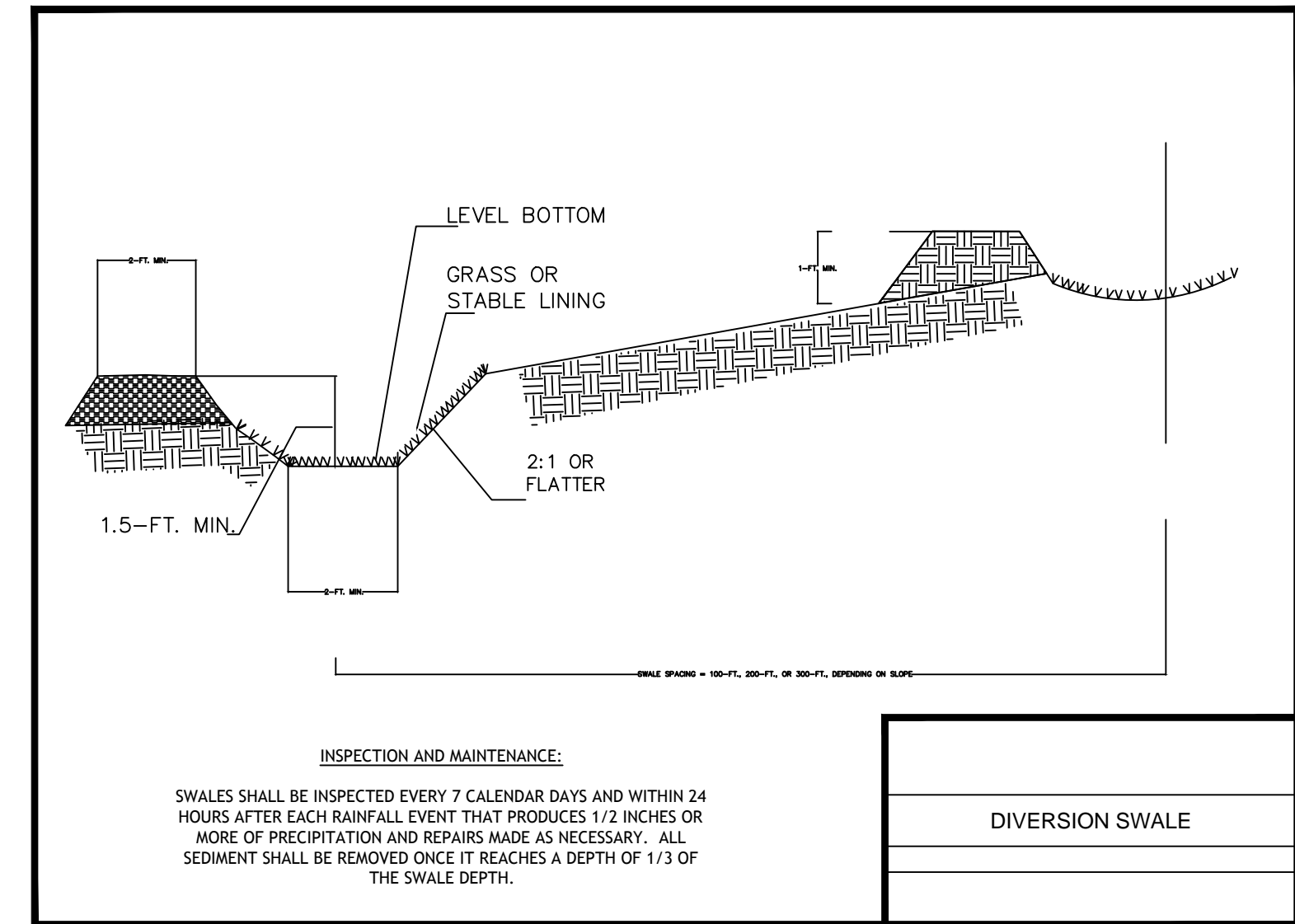

INSPECTION AND MAINTENANCE:
SWALES SHALL BE INSPECTED EVERY 7 CALENDAR DAYS AND WITHIN 24 HOURS AFTER EACH RAINFALL EVENT THAT PRODUCES 1/2 INCHES OR MORE OF PRECIPITATION AND REPAIRS MADE AS NECESSARY. ALL SEDIMENT SHALL BE REMOVED ONCE IT REACHES A DEPTH OF 1/3 OF THE SWALE DEPTH.

DIVERSION SWALE

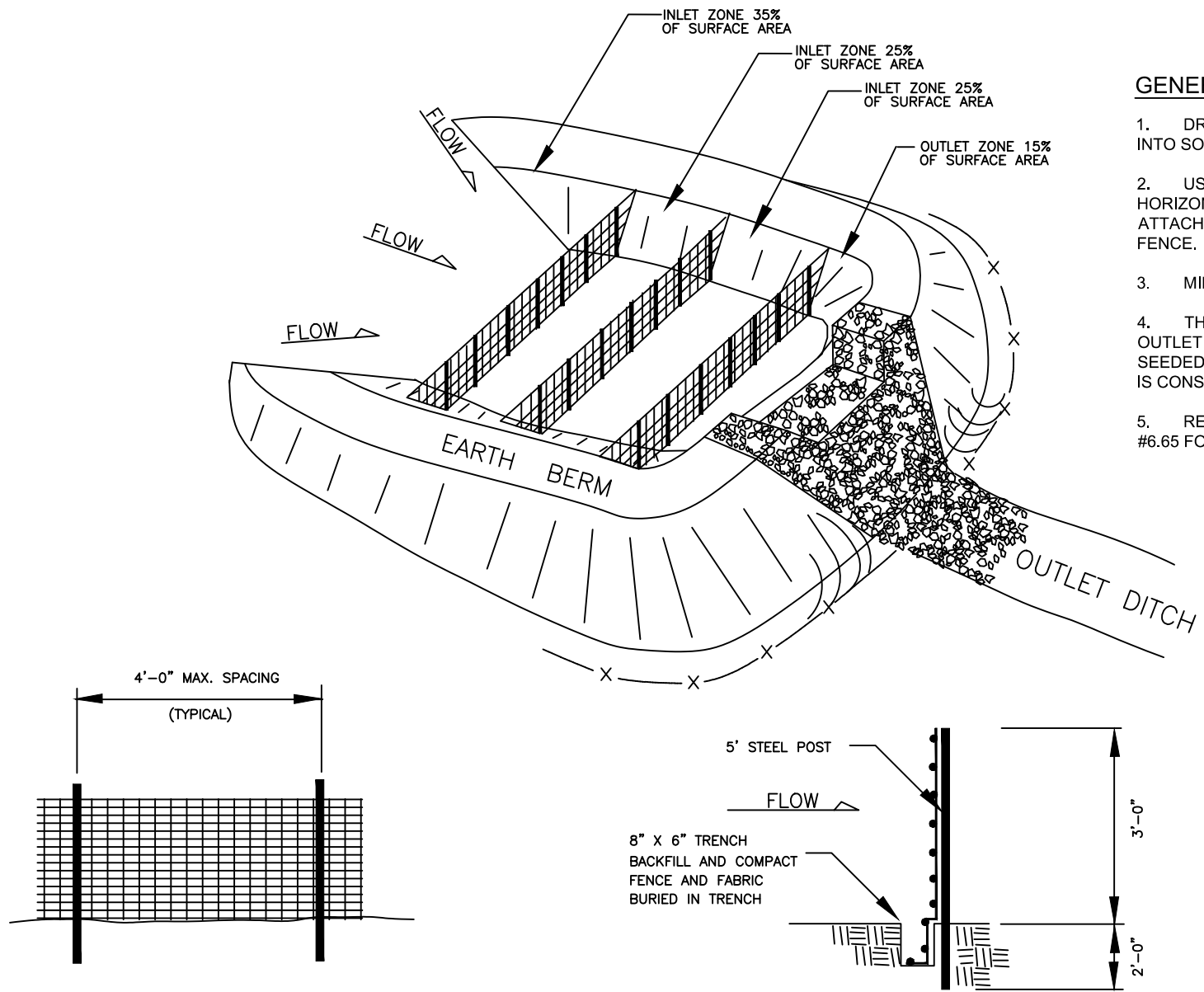

GENERAL NOTES:

- DRIVE 5' STEEL POST AT LEAST 24" INTO SOLID GROUND.
- USE STAPLES 1' APART HORIZONTALLY AND VERTICALLY TO ATTACH THE FILTER FABRIC TO THE WIRE FENCE.
- MINIMUM BAFFLE SPACING IS 10'.
- THE FLOOR OF THE BASIN IN THE OUTLET ZONE AND BERMS SHOULD BE SEEDED IMMEDIATELY AFTER THE BASIN IS CONSTRUCTED.
- REFER TO NCESCPDM SECTION #6.65 FOR ADDITIONAL SPECIFICATIONS.

BAFFLE INSTALLATION



CITY OF WILMINGTON
NORTH CAROLINA

Public Services • Engineering Division

APPROVED STORMWATER MANAGEMENT PLAN

Date: _____ Permit # _____

Signed: _____

Approved Construction Plan

Name _____ Date _____

Planning _____

Traffic _____

Fire _____



Bluewater Civil Design, PLLC
NC P-0868

PLAN REVISION	ISSUE DATE	ISSUE COMMENT
A	2-3-2015	ISSUED FOR PERMITS

PLAN REVISION	ISSUE DATE	ISSUE COMMENT
A	2-3-2015	ISSUED FOR PERMITS

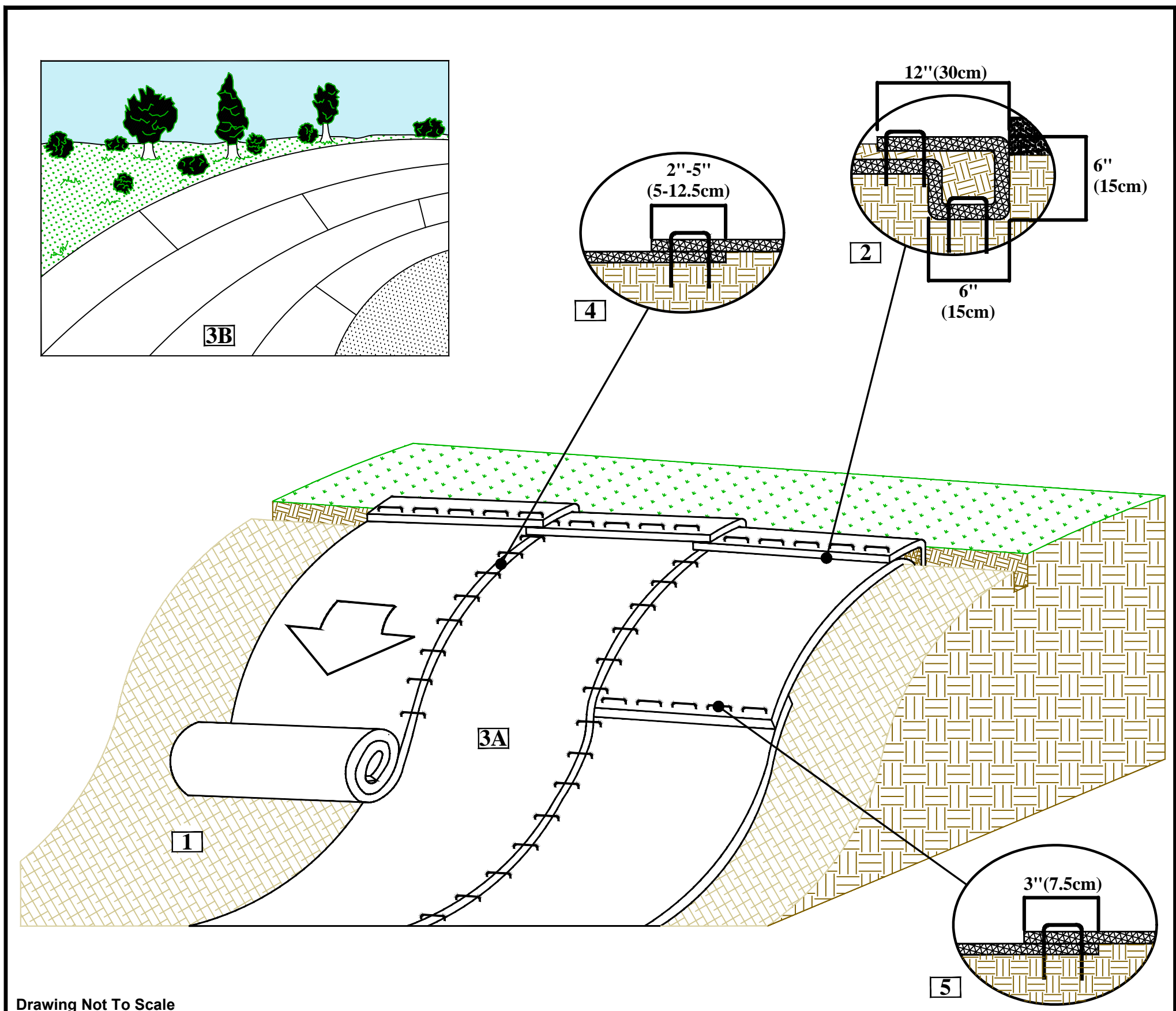

SLOPE INSTALLATION DETAIL

1. Prepare soil before installing rolled erosion control products (RECPS), including any necessary application of lime, fertilizer, and seed.
2. Begin at the top of the slope by anchoring the RECPS in a 6"(15cm) deep X 6"(15cm) wide trench with approximately 12" (30cm) of RECPS extended beyond the up-slope portion of the trench. Anchor the RECPS with a row of staples/stakes approximately 12" (30cm) apart in the bottom of the trench. Backfill and compact the trench after stapling. Apply seed to the compacted soil and fold the remaining 12"(30cm) portion of RECPS back over the seed and compacted soil. Secure RECPS over compacted soil with a row of staples/stakes spaced approximately 12"(30cm) apart across the width of the RECPS.
3. Roll the RECPS (A) down or (B) horizontally across the slope. RECPS will unroll with appropriate side against the soil surface. All RECPS must be securely fastened to soil surface by placing staples/stakes in appropriate locations as shown in the staple pattern guide.
4. The edges of parallel RECPS must be stapled with approximately 2" - 5" (5-12.5cm) overlap depending on the RECPS type.
5. Consecutive RECPS spliced down the slope must be end over end (Shingle style) with an approximate 3"(7.5cm) overlap. Staple through overlapped area, approximately 12"(30cm) apart across entire RECPS width.

Drawing Not To Scale

Tensor. NORTH AMERICAN GREEN
 5401 St. Wendel - Cynthia Rd. Poseyville, IN 47633
 PH: 800-722-2040
 www.nagreen.com

Disclaimer: The information presented herein is general design information only. For specific applications, consult an independent professional for further design guidance.

Drawn on: 3-16-11

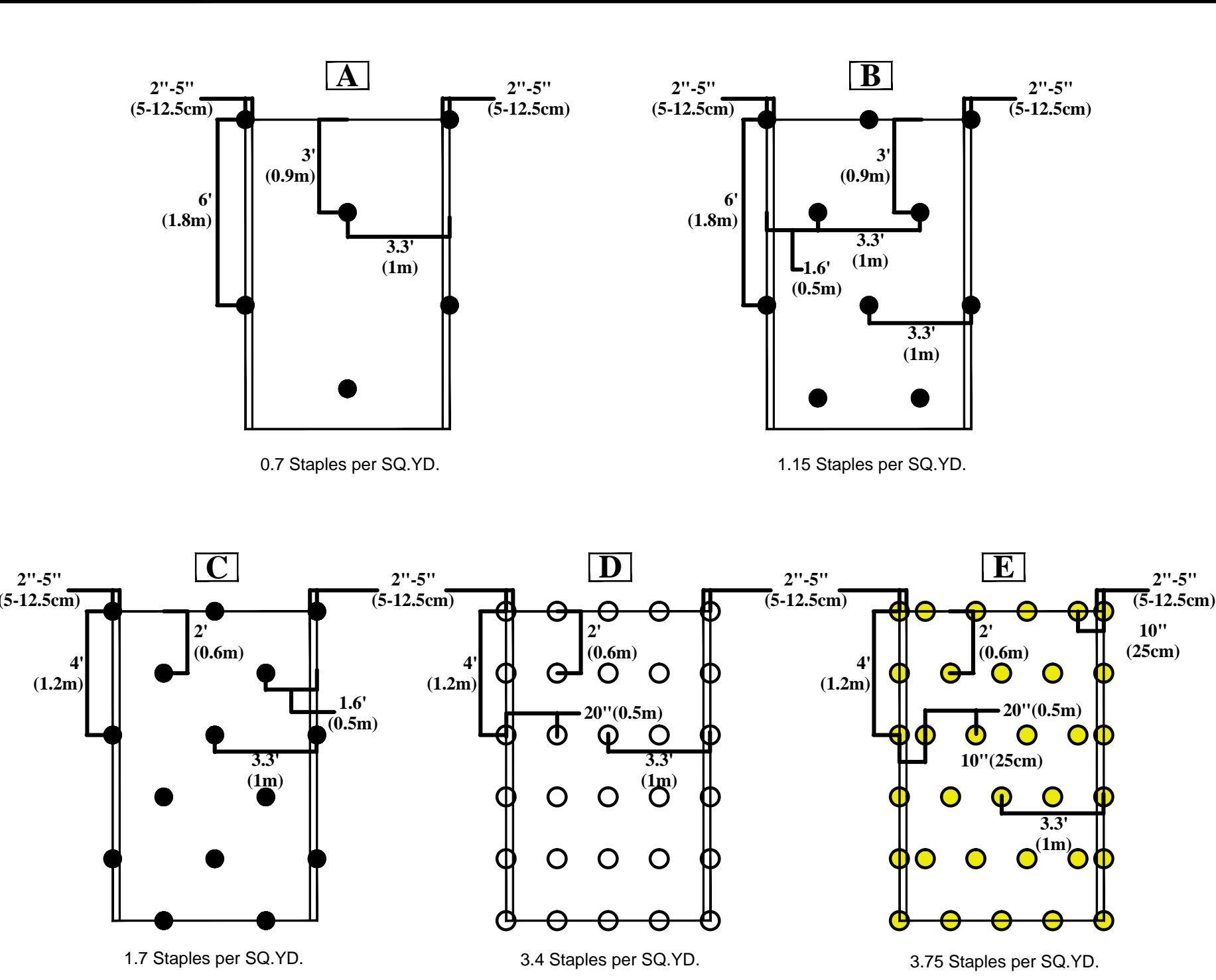
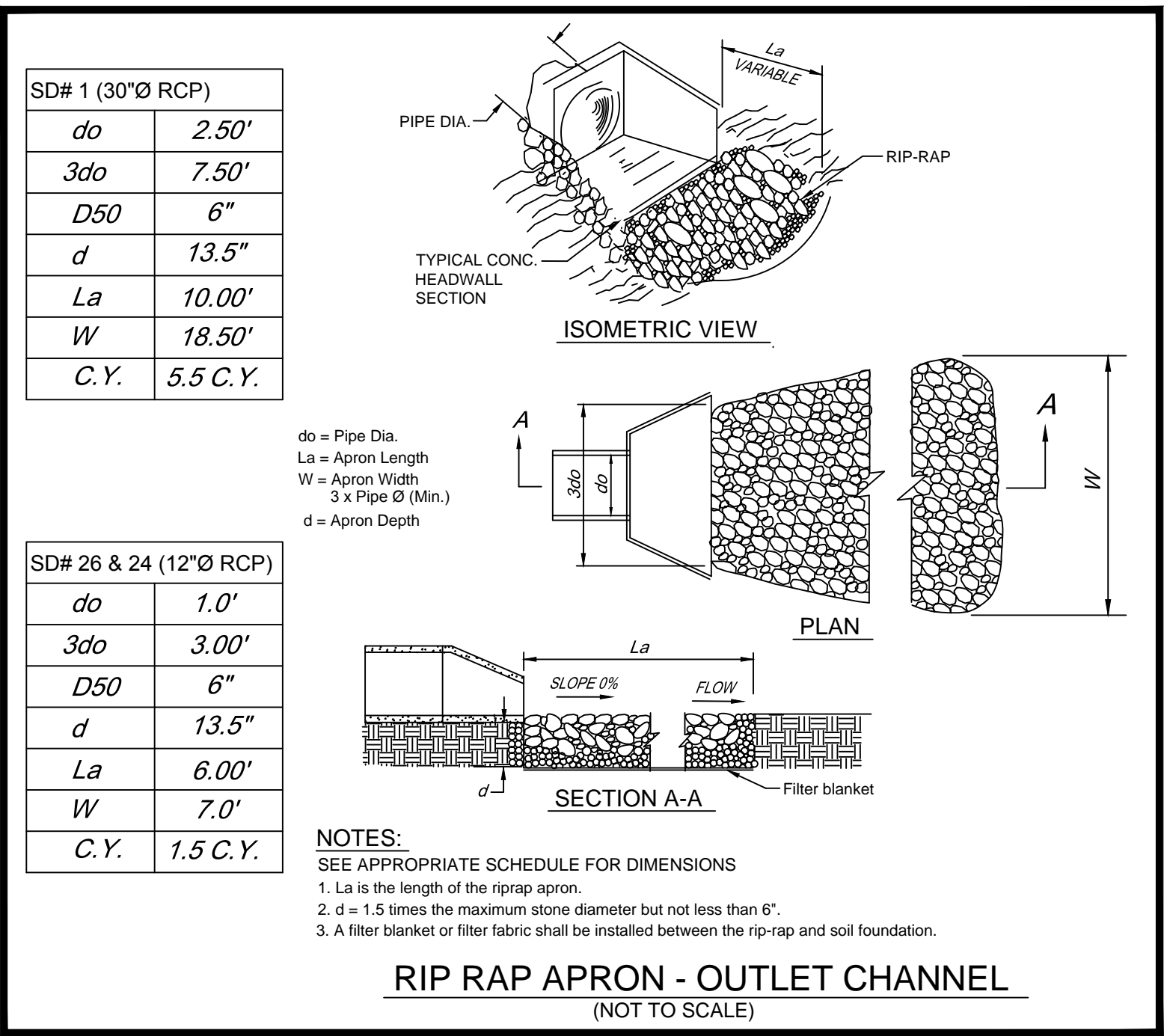

STAPLE PATTERN GUIDE

- 4:1 Slopes (A)
- 3:1 Slopes (B)
- 2:1 Slopes (C)
- 1:1 & Steeper Slopes (D)
- Medium/High Flow Channel (D)
- High Flow Channel And Shoreline (E)

NOTES:
 * Use ECMDS® for more accurate staple pattern selection.

Drawing Not To Scale

Tensor. NORTH AMERICAN GREEN
 5401 St. Wendel - Cynthia Rd. Poseyville, IN 47633
 PH: 800-722-2040
 www.nagreen.com

Disclaimer: The information presented herein is general design information only. For specific applications, consult an independent professional for further design guidance.

Drawn on: 3-16-11

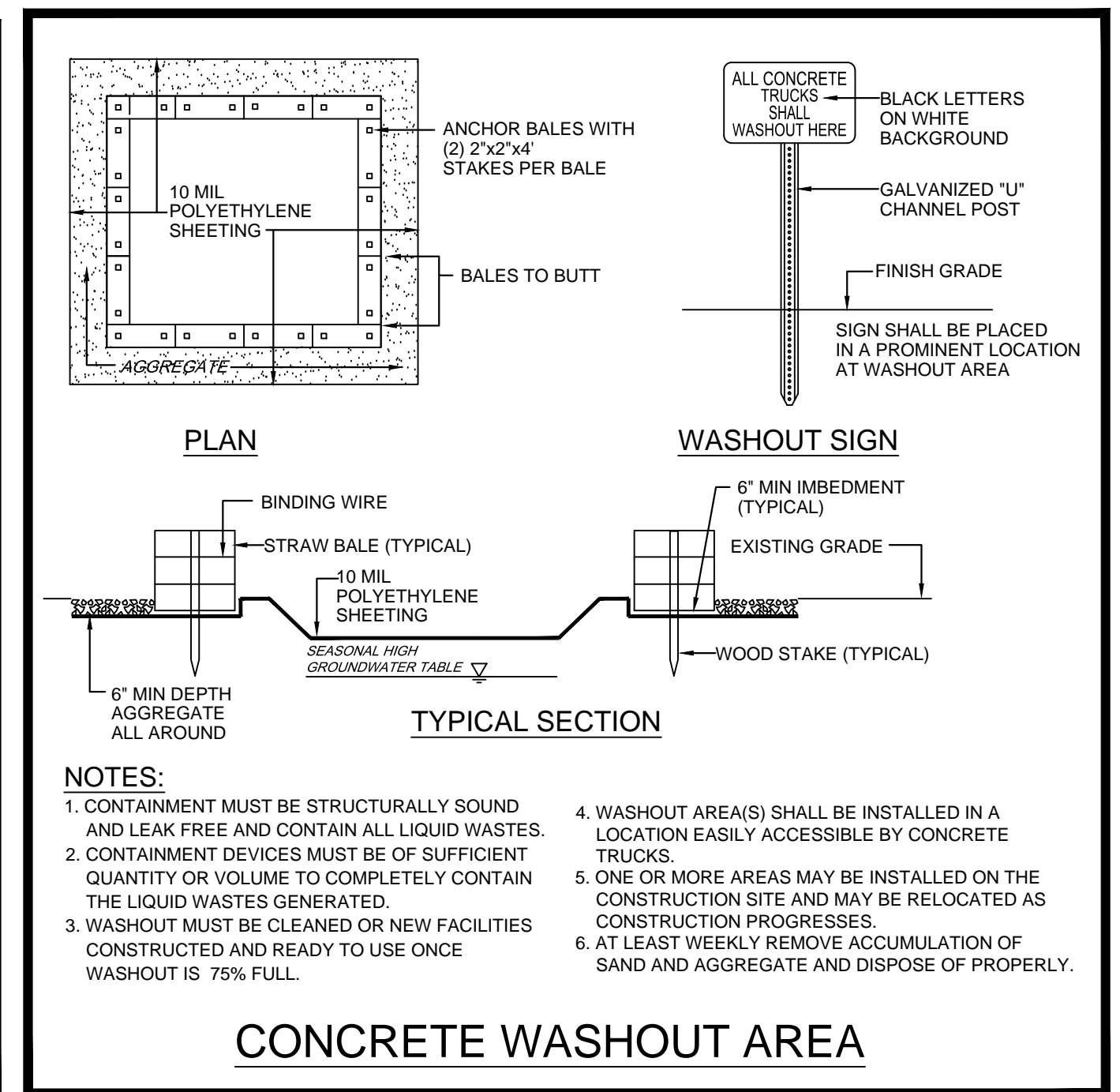
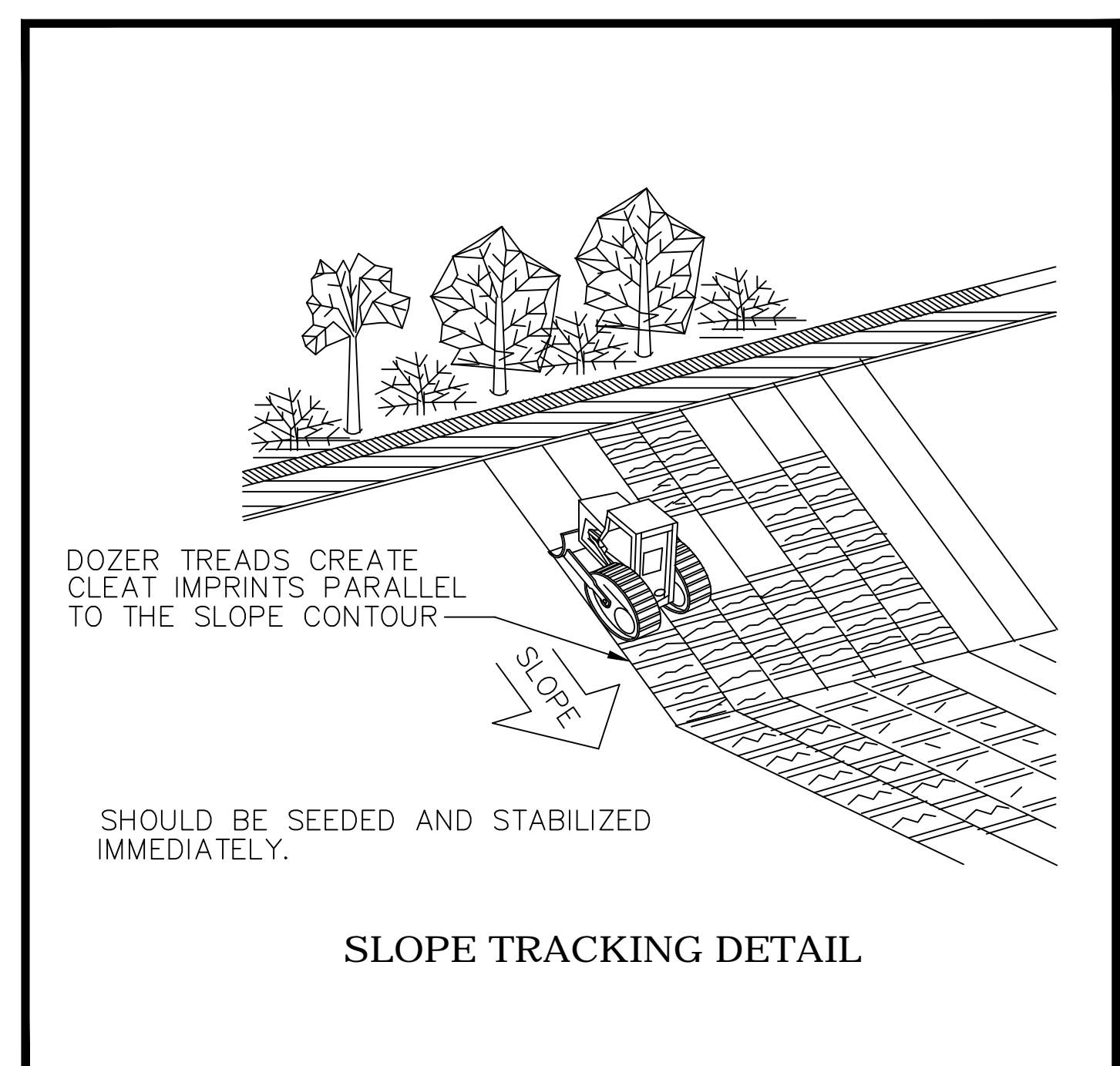

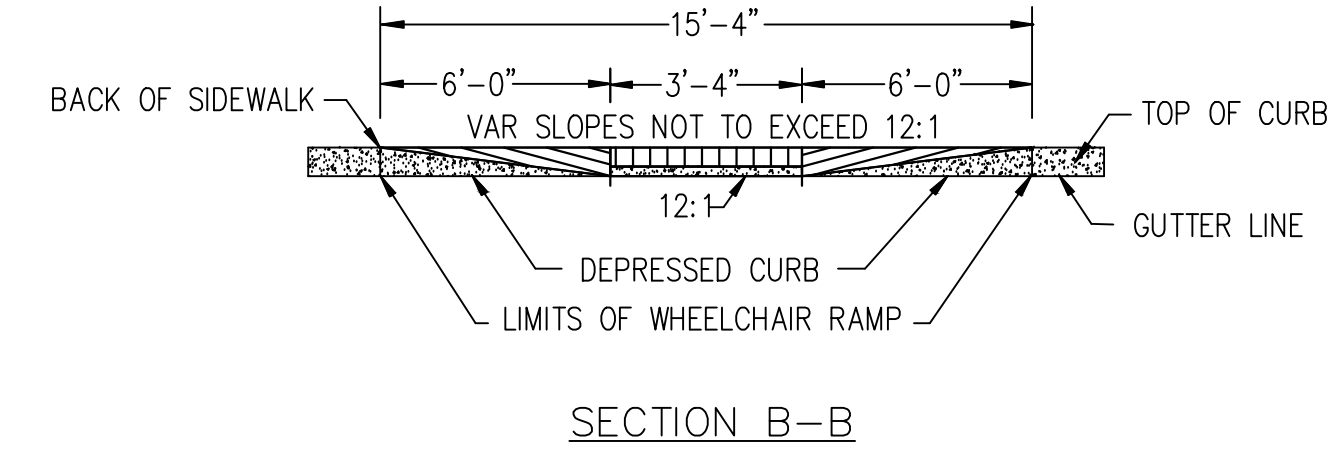
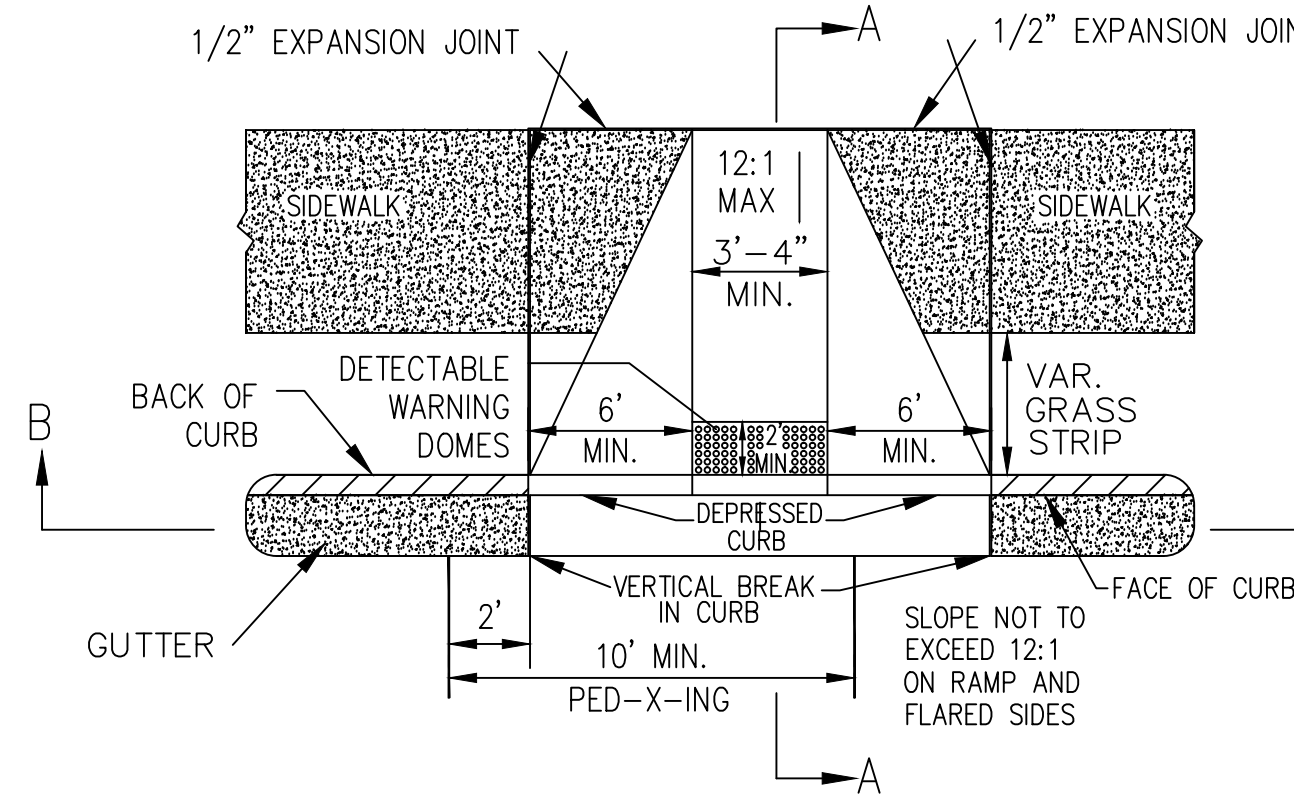
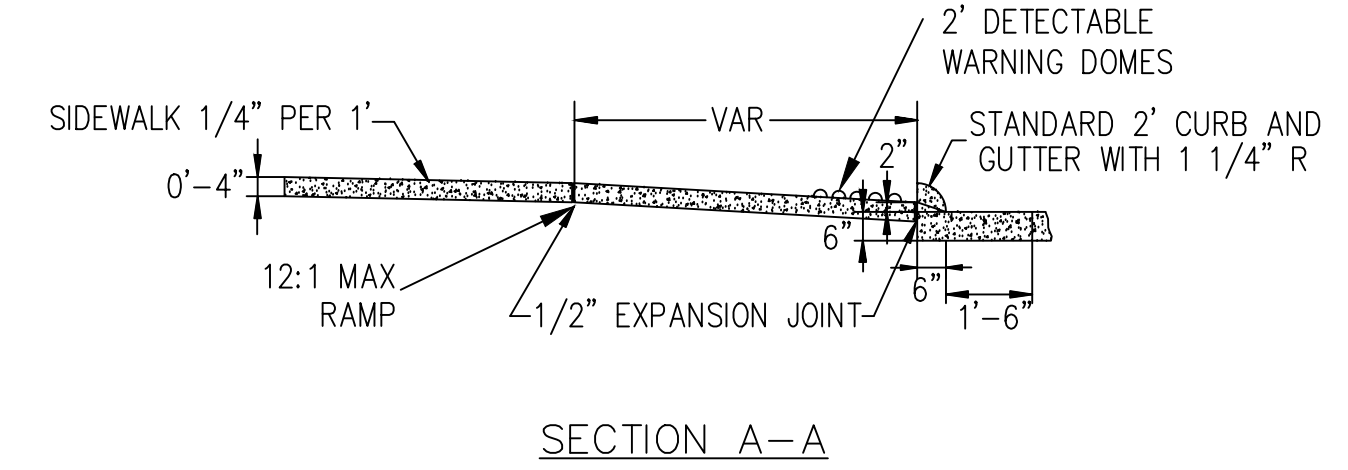
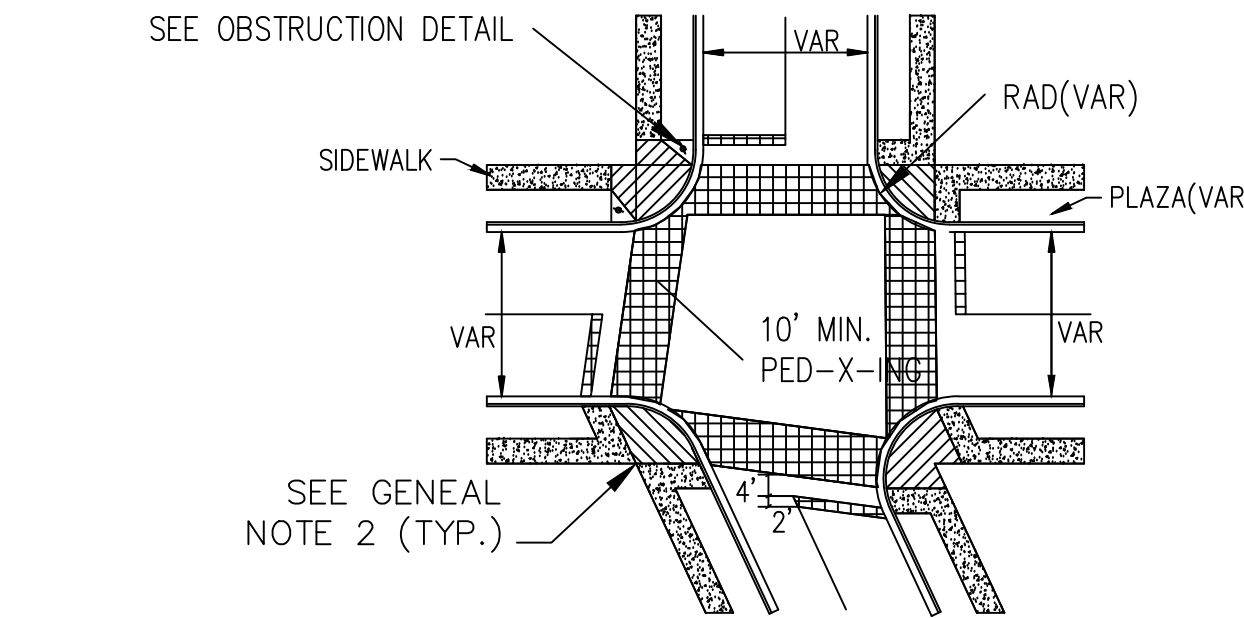
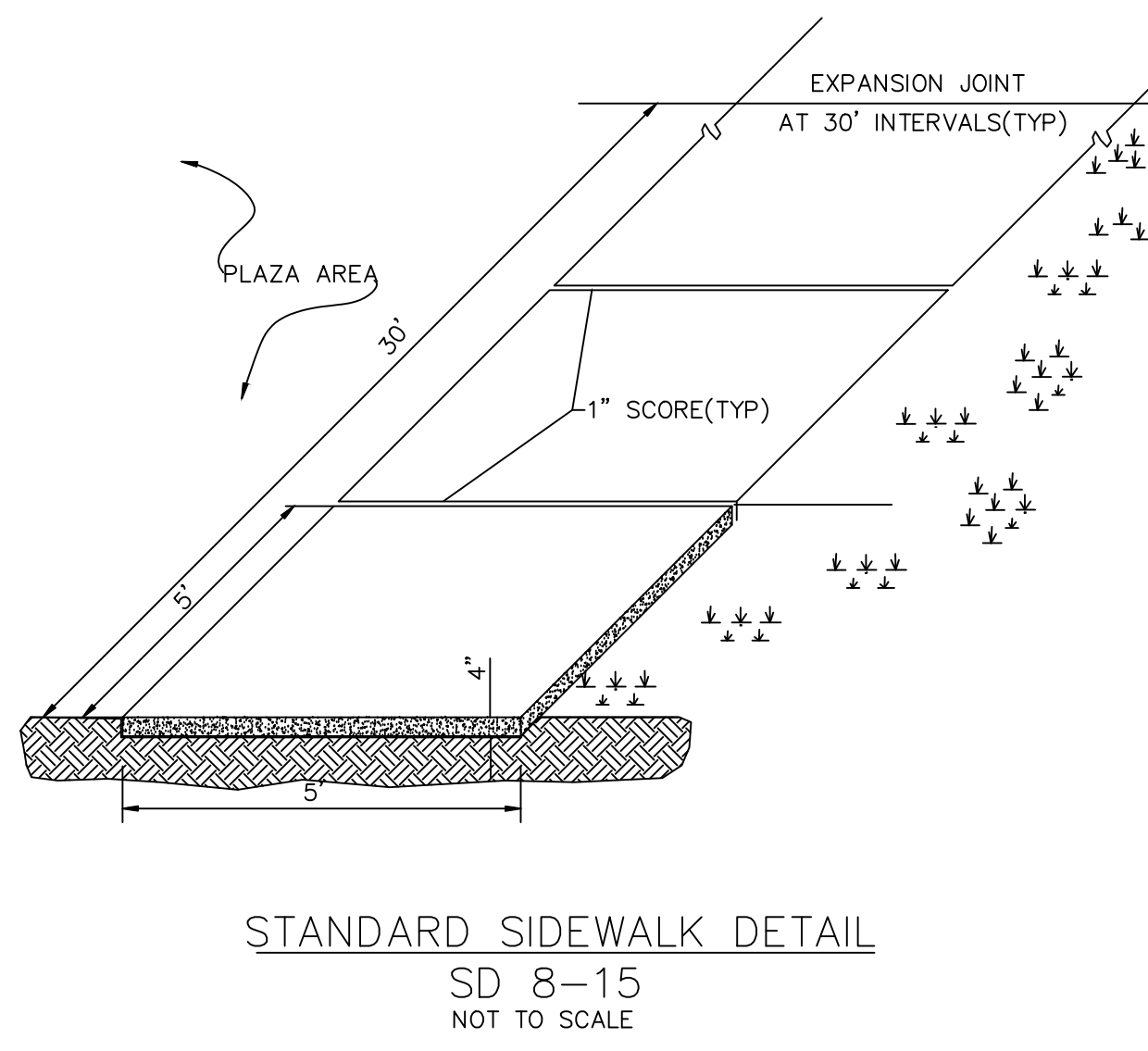
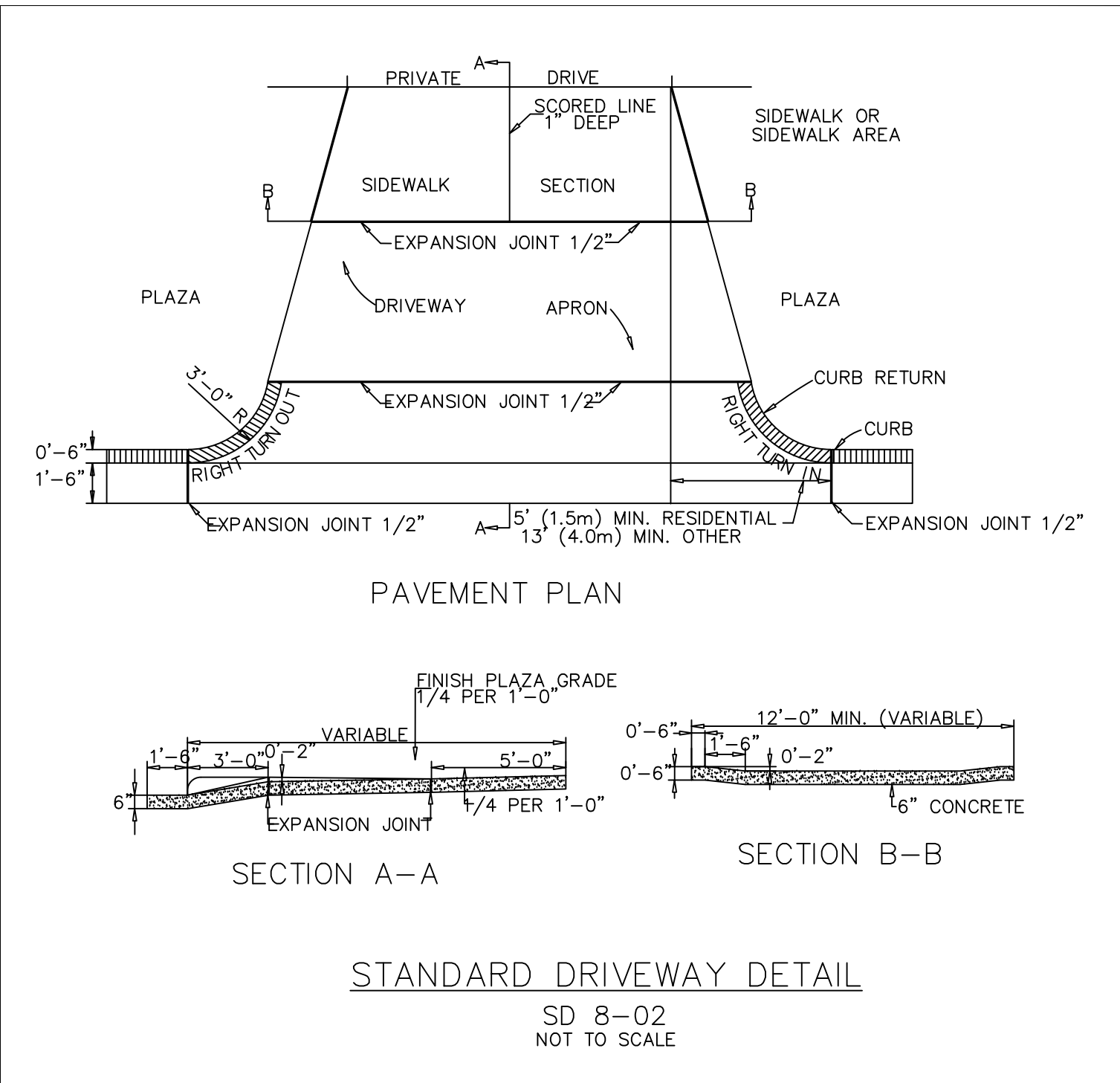

GUIDELINES FOR WHEELCHAIR RAMPS & DEPRESSED CURBS SD 8-10

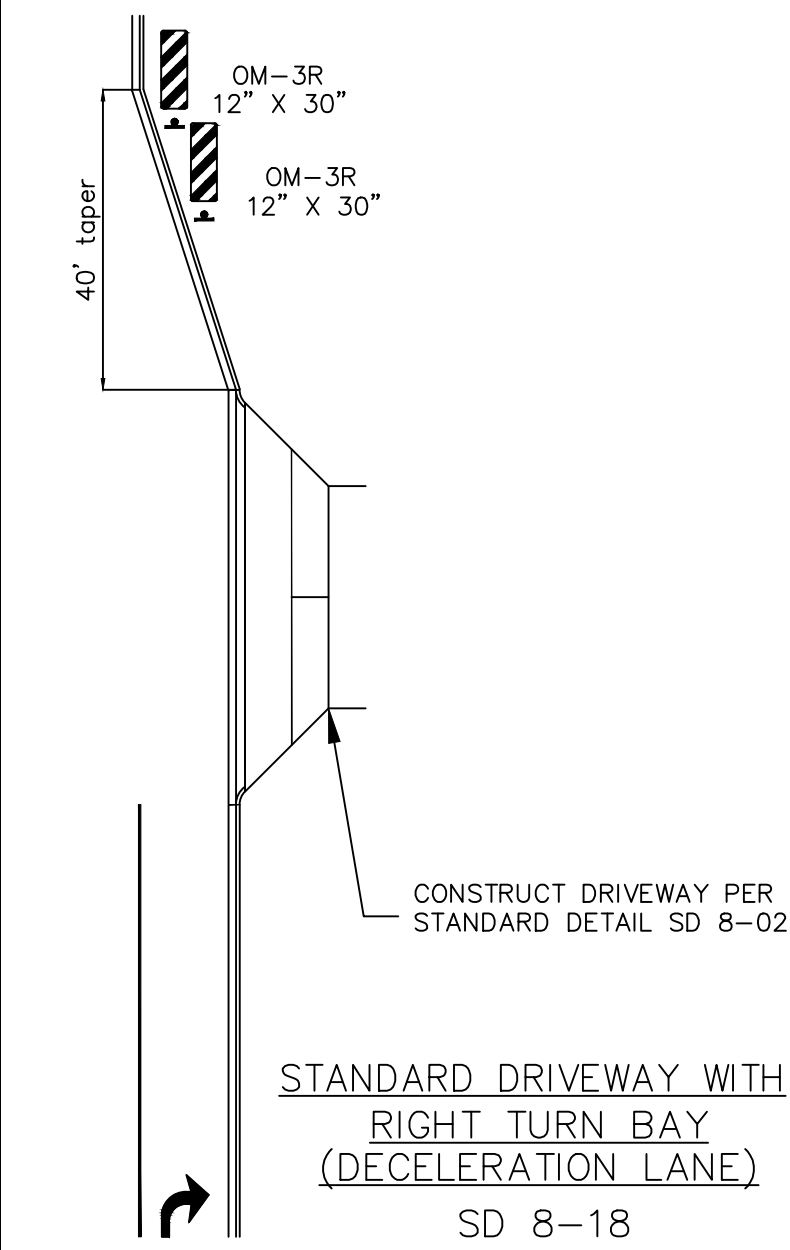

GENERAL NOTES
 1. In accordance with N.C.G.S. 136-44.14, all street curbs being constructed or reconstructed shall provide wheelchair ramps for the physically handicapped on each side of any street or road, where curbs and sidewalks are provided and at other major points of pedestrian flow.
 2. Wheelchair ramps shall be located as indicated in detail drawings; however, existing light poles, fire hydrants, drop inlets, etc. may affect placement.
 3. Curb ramps shall have detectable warnings extending the full width of the ramp and a minimum of 2-ft. in length.

CONSTRUCTION NOTES
 1. Construction shall conform with construction standards of the governing body which has jurisdiction of the particular street. concrete with the surface having a 'A' finish.
 2. Wheelchair ramps shall be constructed of Class rough, non-skid type finish.
 3. A 1/2-in. expansion joint shall be required where the concrete wheelchair ramp joins any rigid pavement or structure.
 4. In no case shall the width of a curb ramp or curb cut be less than 40-in. (3-ft., 4-in.), not including the flared sides.
 5. Transitions from ramps to walks, gutters or streets shall be flush and free of abrupt changes.
 6. The maximum slope on the curb ramp run is 1:12.
 7. The maximum cross slope of the curb ramp is 1:50.
 8. Maximum slopes of adjoining gutters, road surface immediately adjacent to the curb ramp, or accessible route shall not exceed 1:20.
 9. Any raised islands in crossings shall be cut through level with the street or have curb ramps at both sides and a level area at least 48-in. long between the curb ramps.
 10. Detectable warnings shall consist of raised truncated domes with a diameter of nominal 0.9-in., a height of nominal 0.2-in. and a center-to-center spacing of nominal 2.35-in. and shall contrast visually with adjoining surfaces, either light-on-dark, or dark-on-light.

ADDITIONAL NOTES
 1. Stop bars shall be used where it is important to indicate the point behind which vehicles are required to stop in compliance with a traffic signal, stop sign or other legal requirement.
 2. Parking shall be eliminated a minimum of 20 feet back of the pedestrian crosswalk.
 3. All pavement markings shall be in accordance with the latest edition of the Manual of Uniform Traffic Control Devices, published by the Federal Highway Administration. This document is available from the Superintendent of Documents, U.S. Government Printing Office, Washington, D.C. 20402.
 4. Curb ramps at marked crossings shall be wholly contained within the markings, excluding any flared sides.
 5. The bottom of diagonal (corner type) curb ramps at marked crossings shall have 48-in. minimum clear space within the markings.
 6. If diagonal curb ramps have flared sides, they shall have at least a 24-in. long segment of straight curb located on each side of the curb ramp and within the marked crossing.

GUIDELINES FOR WHEELCHAIR RAMPS SD 8-09

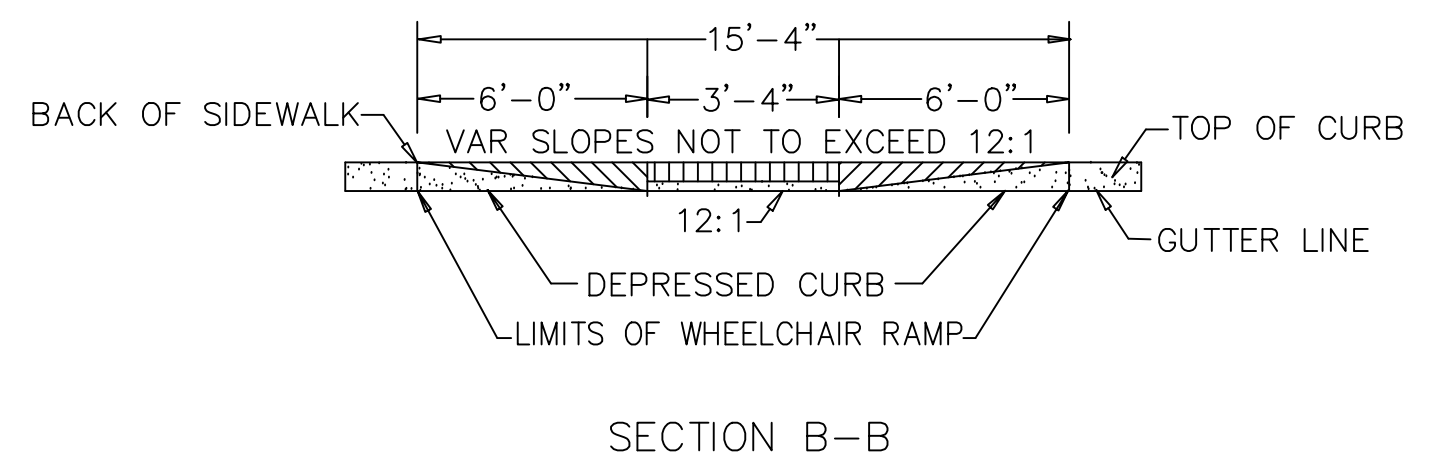
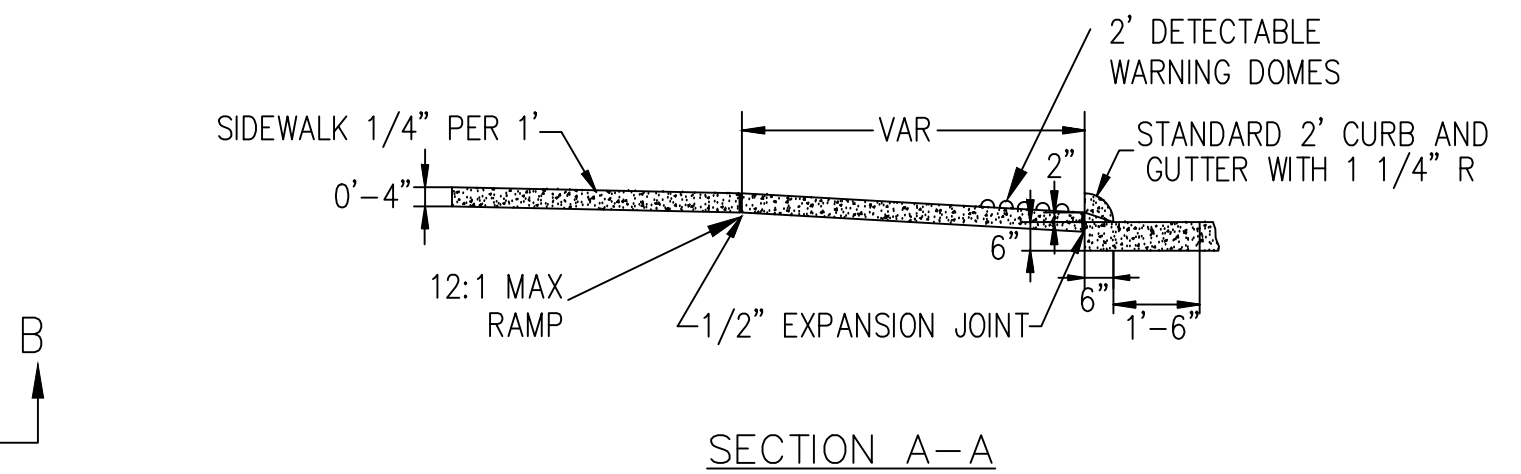
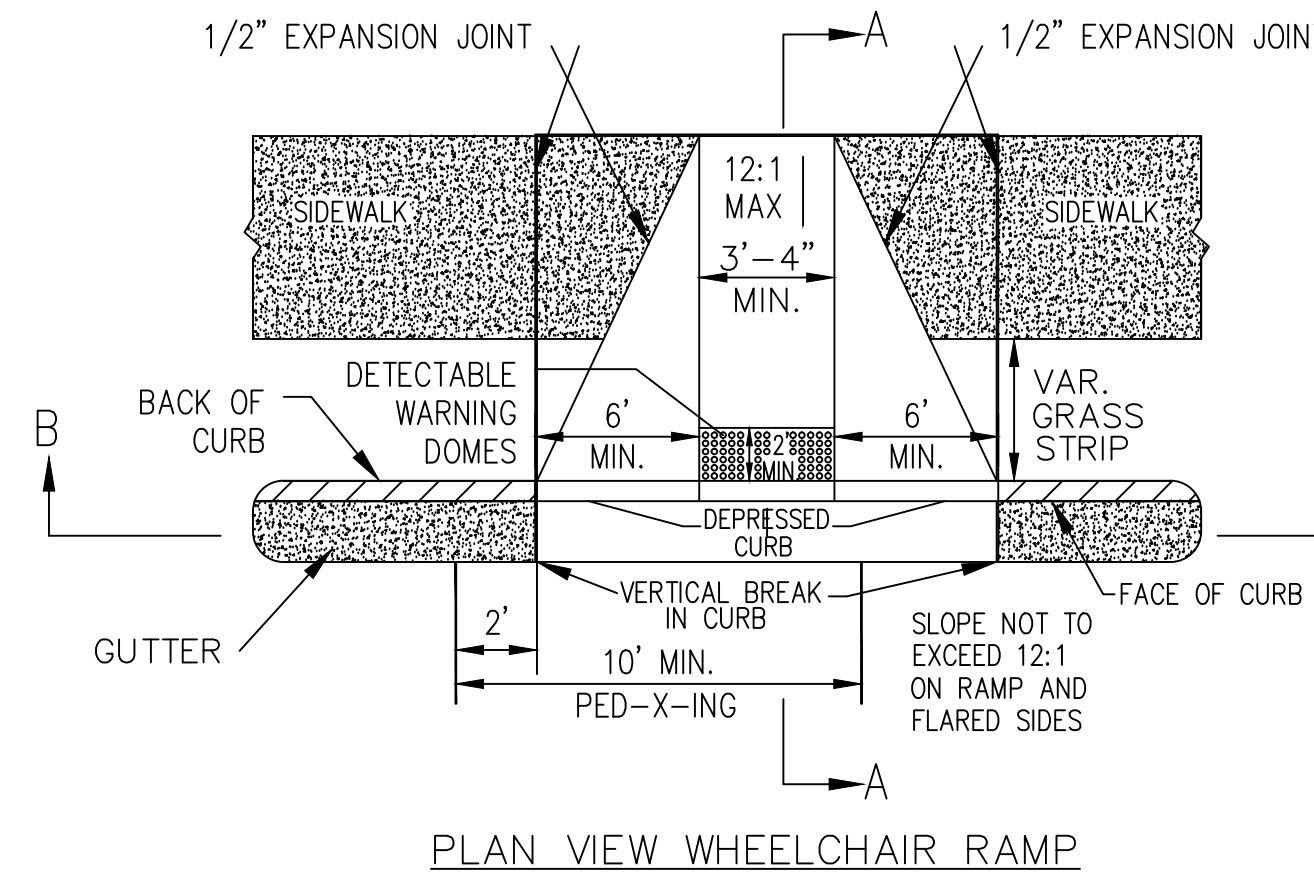
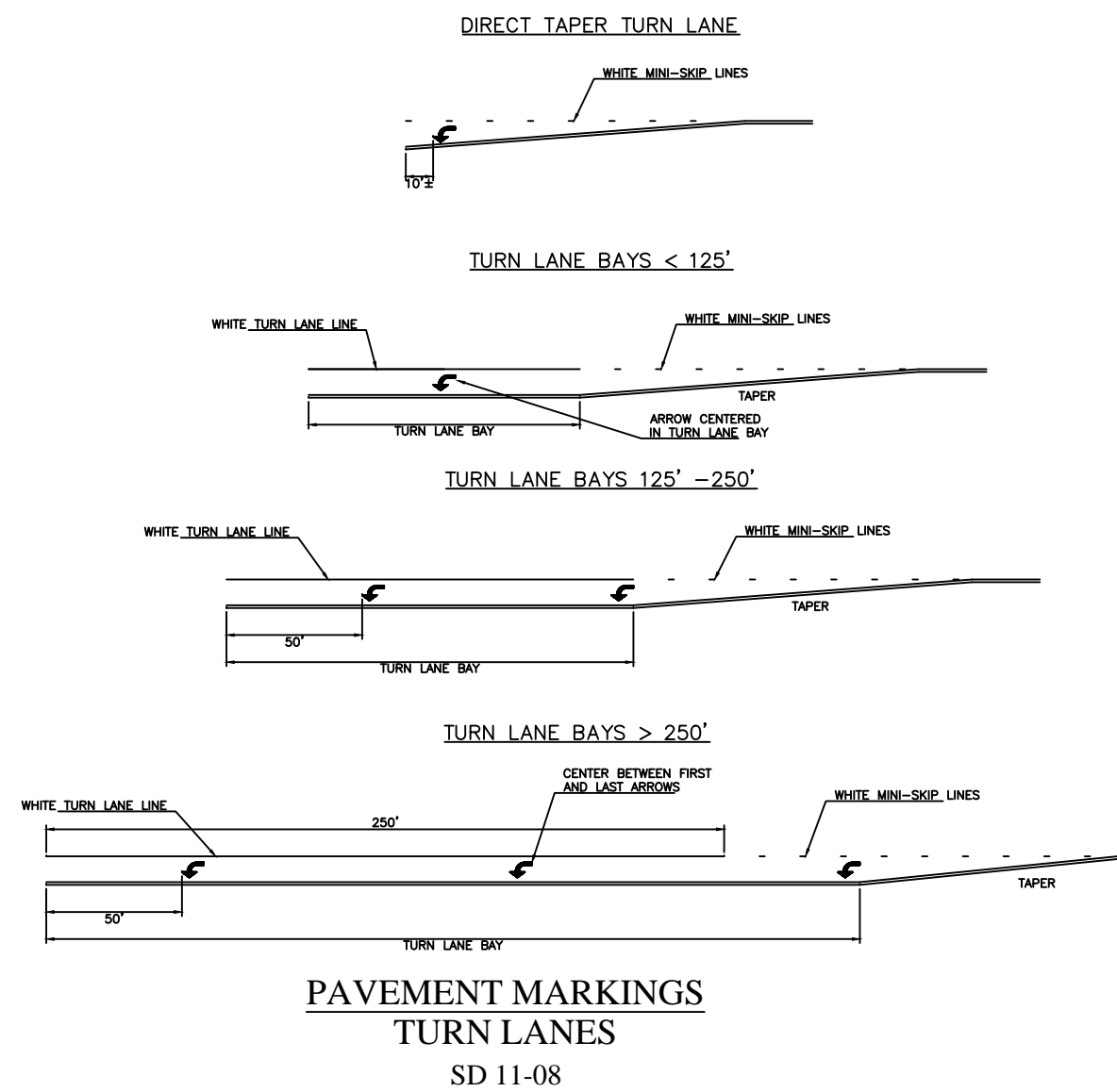
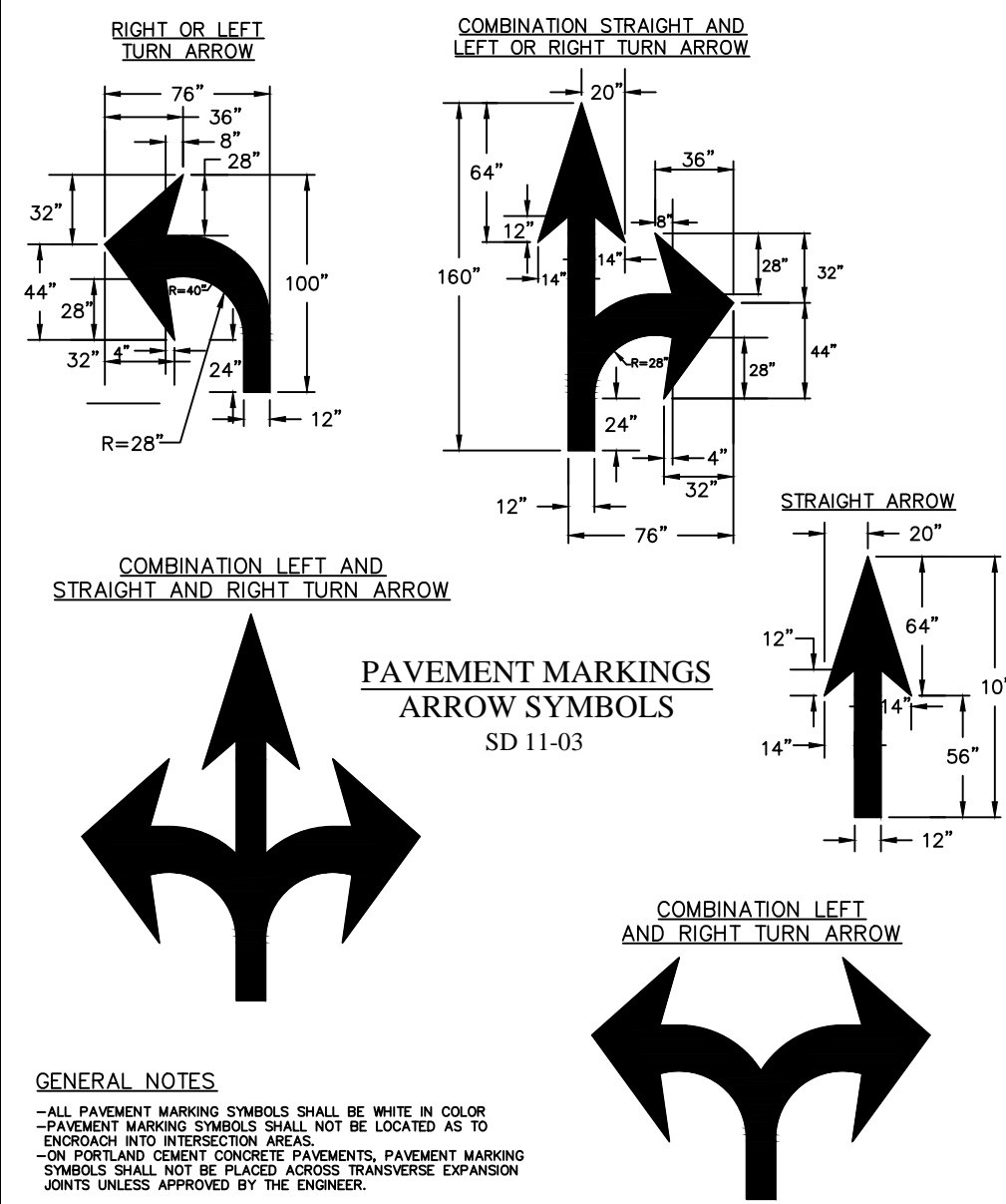

GUIDELINES FOR WHEELCHAIR RAMPS & DEPRESSED CURBS SD 8-11

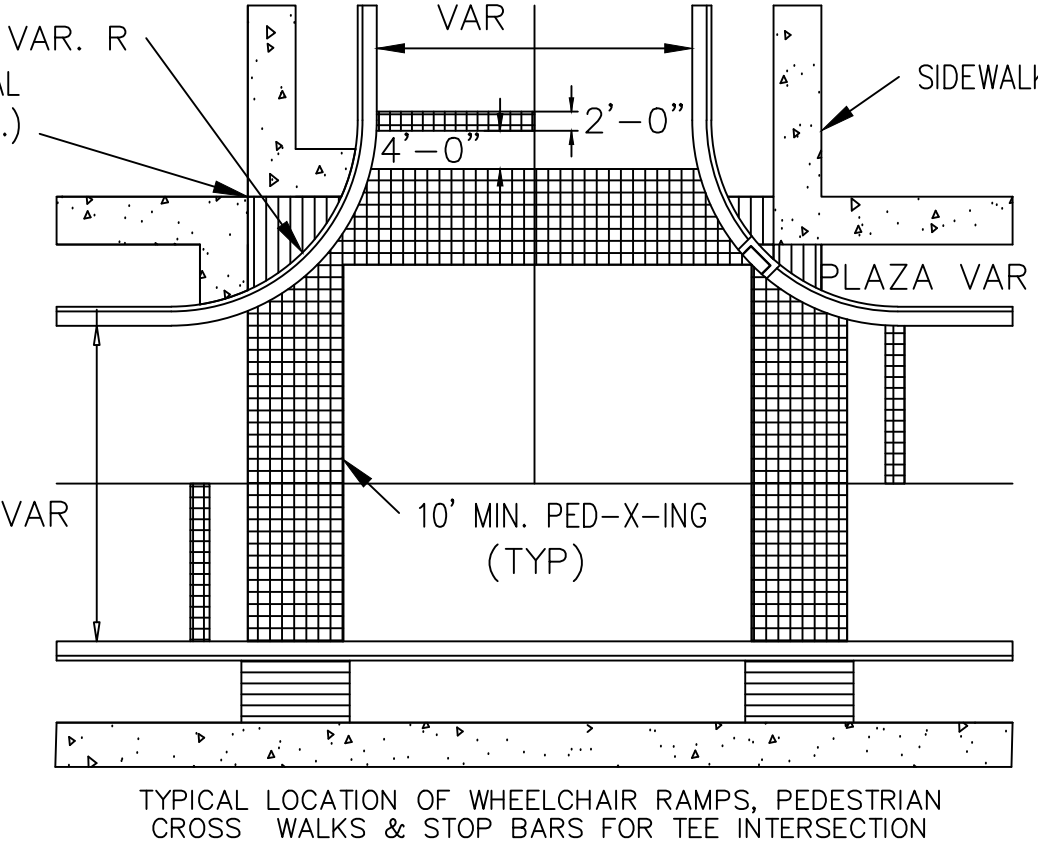

Project Number: 2014-090
 DWG Name: 2014-090 Details.dwg
 Drawing Scale: as noted
 Date of Project: 10-21-2014
 Engineer of Record:
 Jason Henderson, P.E.
 South Carolina P.E. 22806
 Georgia P.E. 63071
 North Carolina P.E. 031306
 Alabama P.E. 52054

bluewater civil design, PLLC
 bluewatercivil.com • info@bluewatercivil.com
 19 Washington Park Suite 100 • Greenville, SC 29601

Certificates of Authorization:
 SC C04212 - GA PEF005865
 NC P0868 - AL CA4065E

BRAGG ROAD DEV. COMPANY, LLC
 Bragg Drive
 Wilmington, NC

Approved Construction Plan
 Name: _____
 Date: _____
 Planning: _____
 Traffic: _____
 Fire: _____

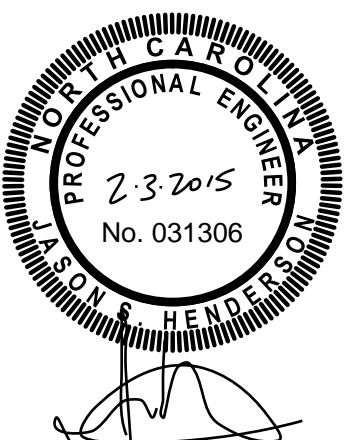

PLAN REVISION	ISSUE DATE	ISSUE COMMENT
A	2-3-2015	ISSUED FOR PERMITS

CITY OF WILMINGTON
 NORTH CAROLINA
 Public Services • Engineering Division
 APPROVED STORMWATER MANAGEMENT PLAN
 Date: _____ Permit # _____
 Signed: _____

NOTES & DETAILS
C506

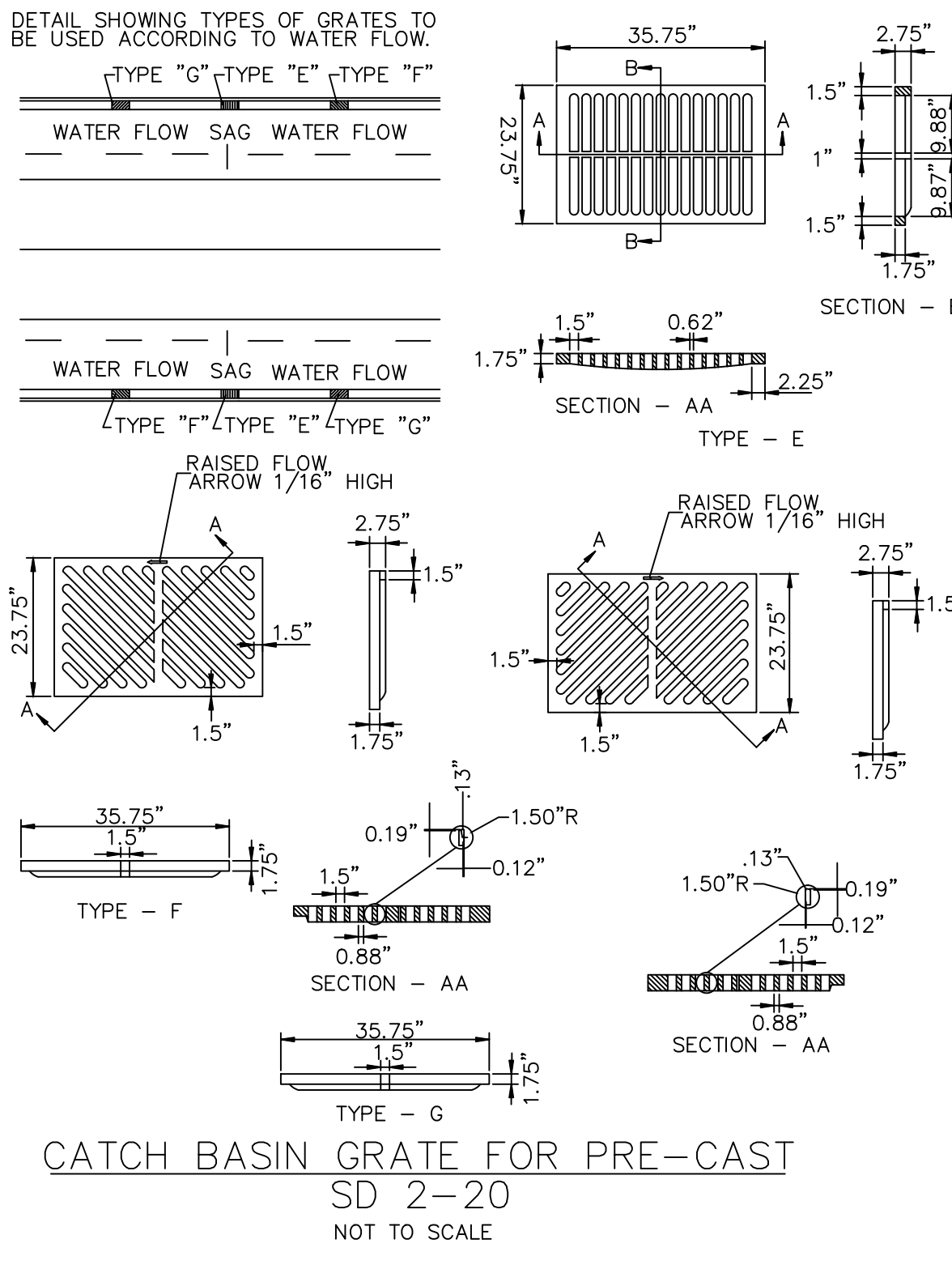
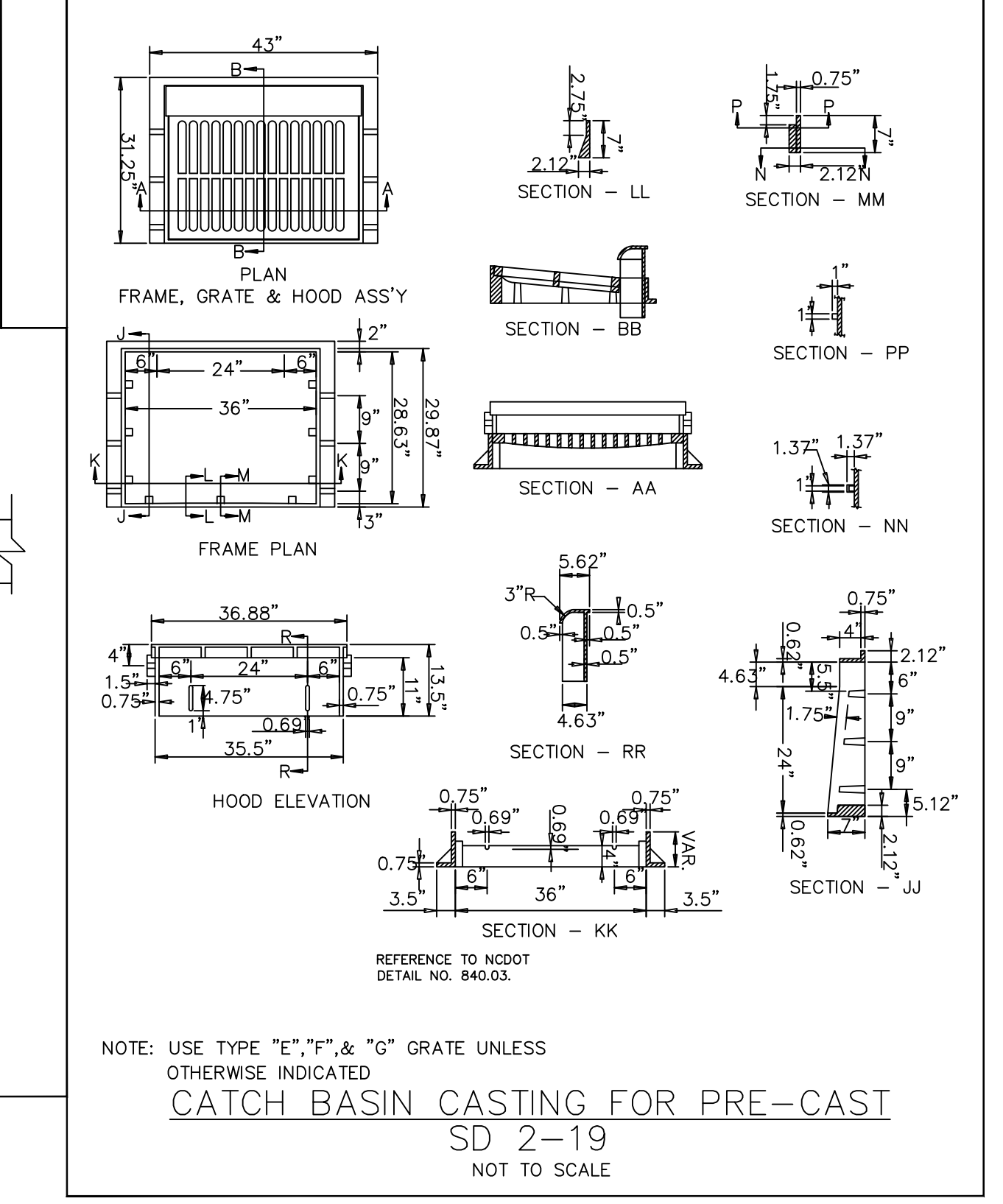
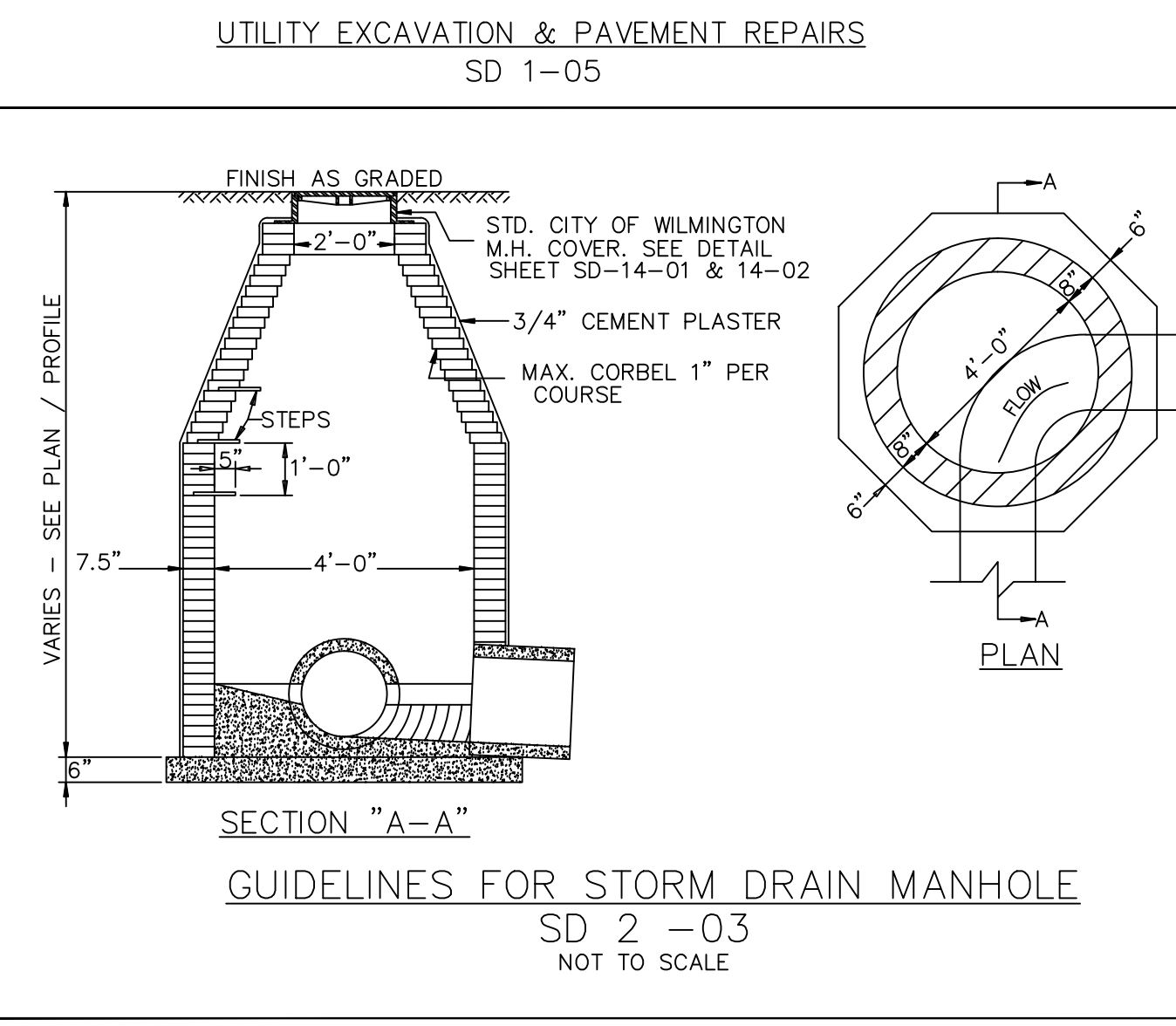
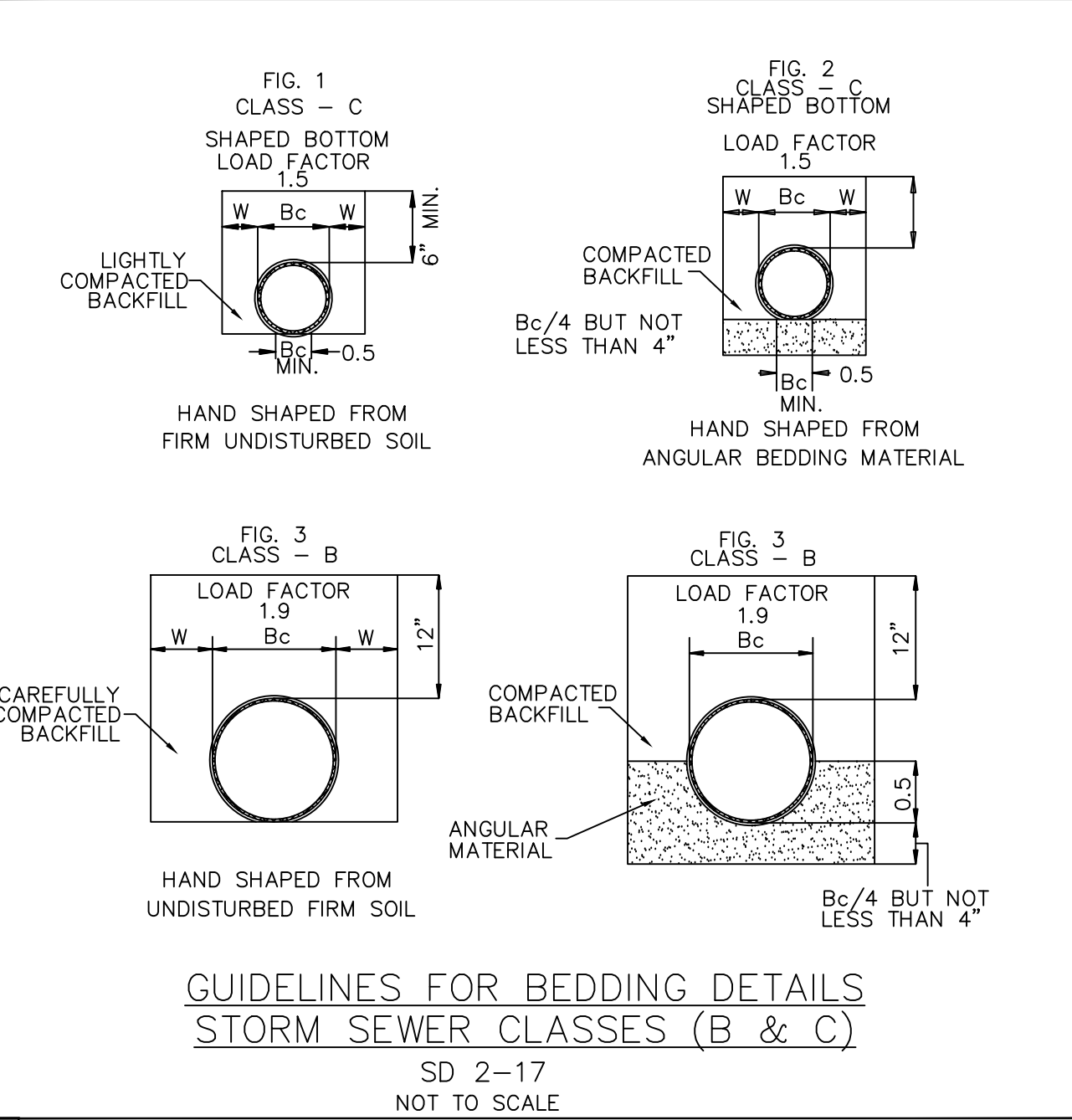
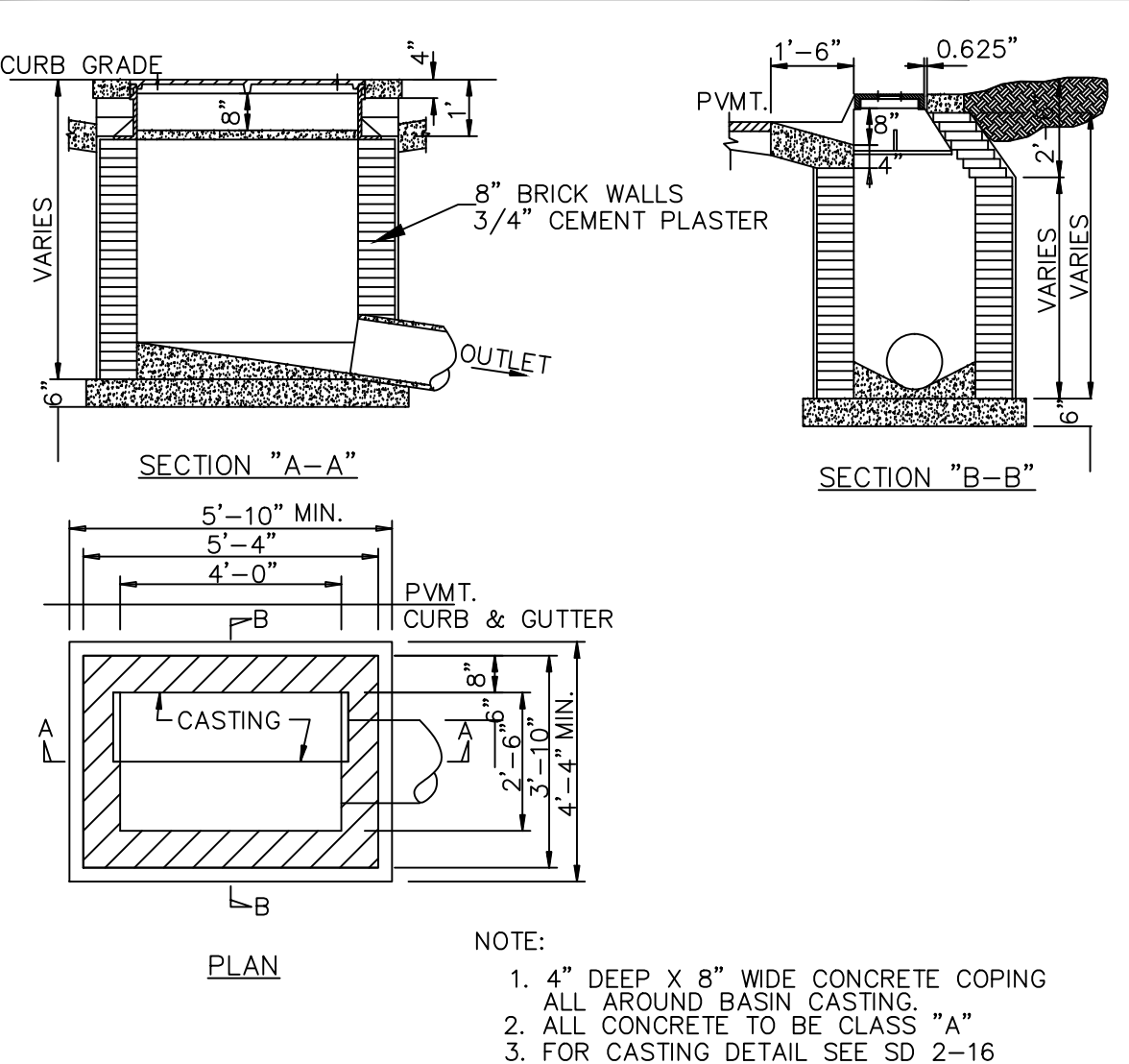
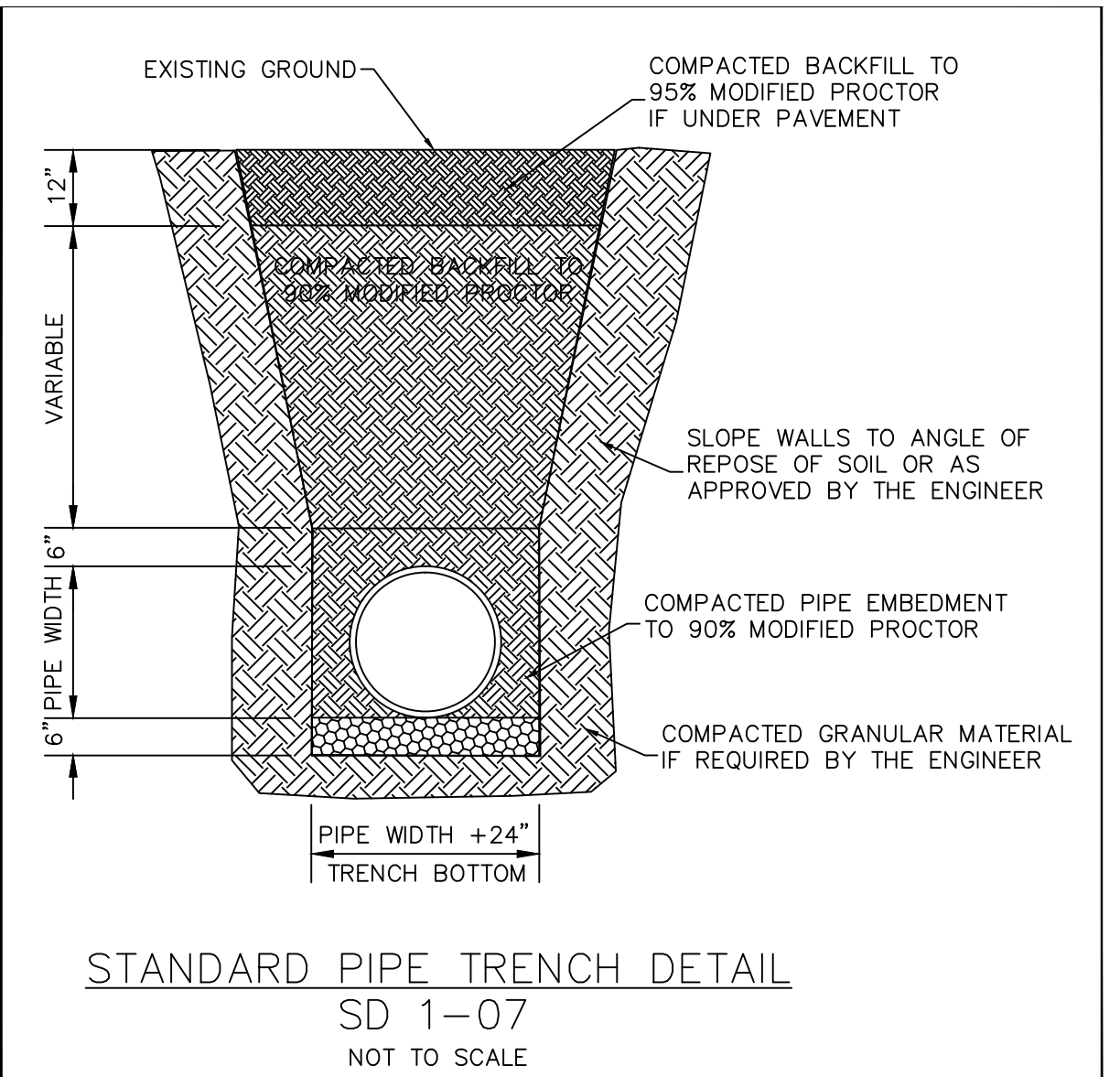
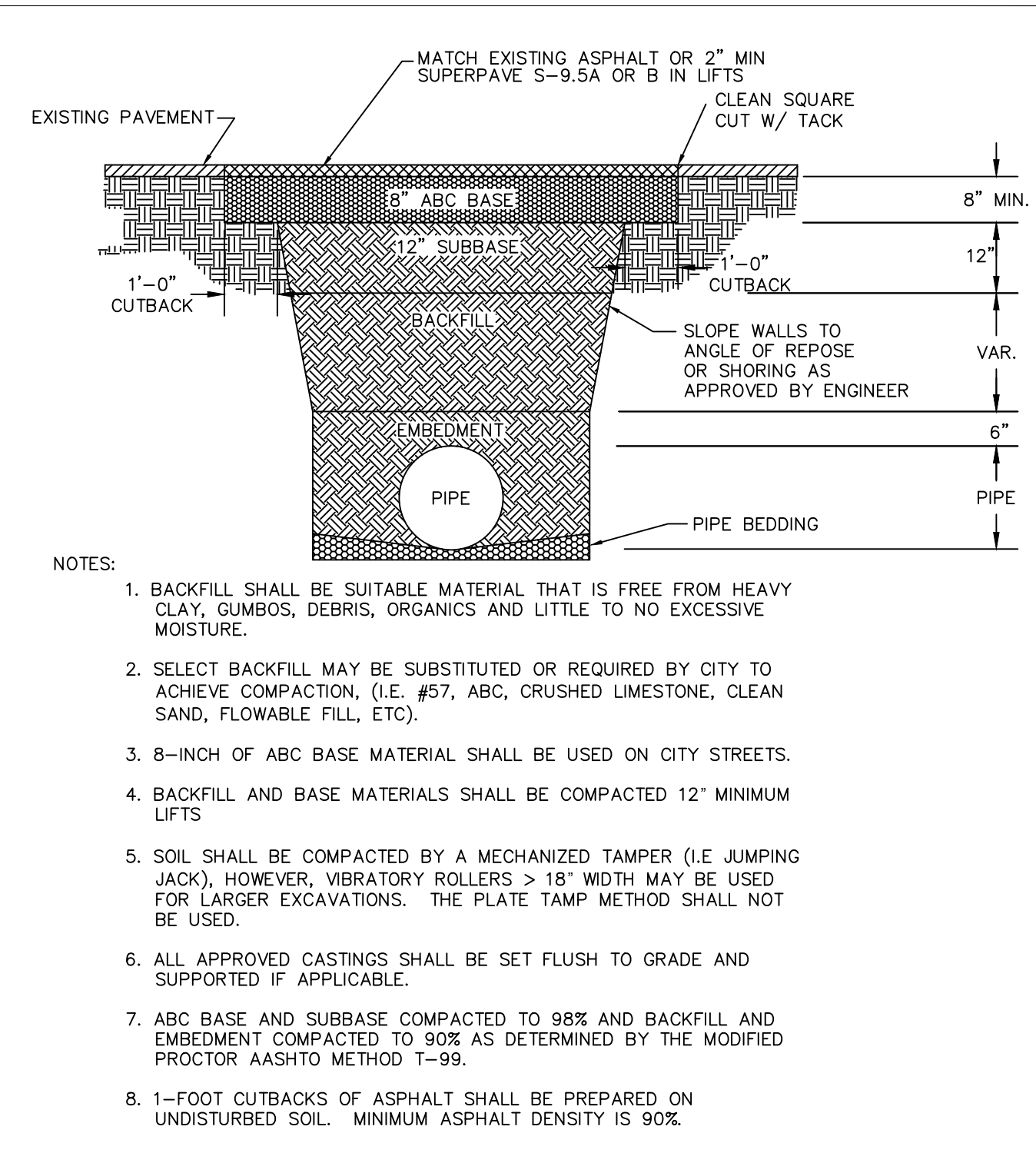
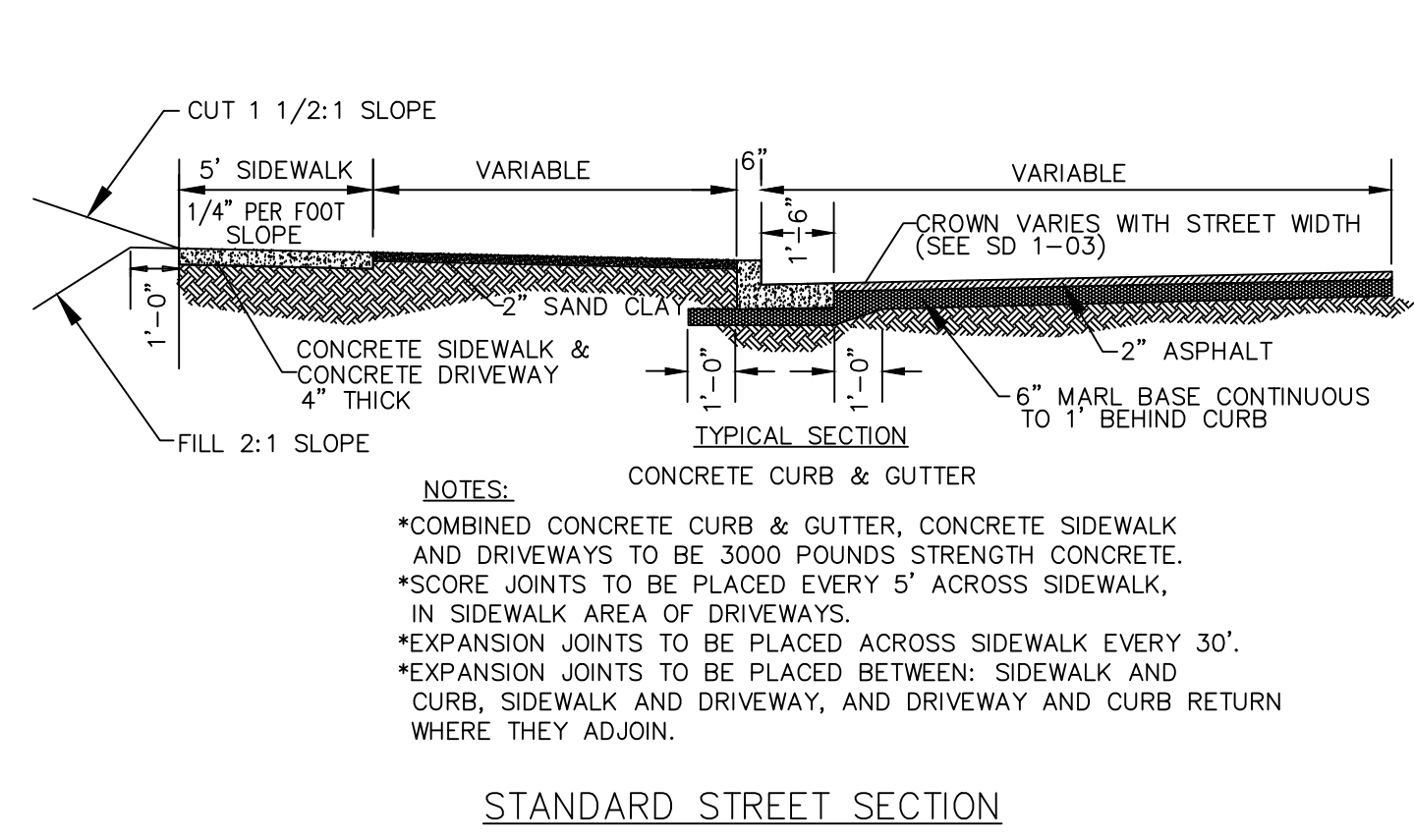
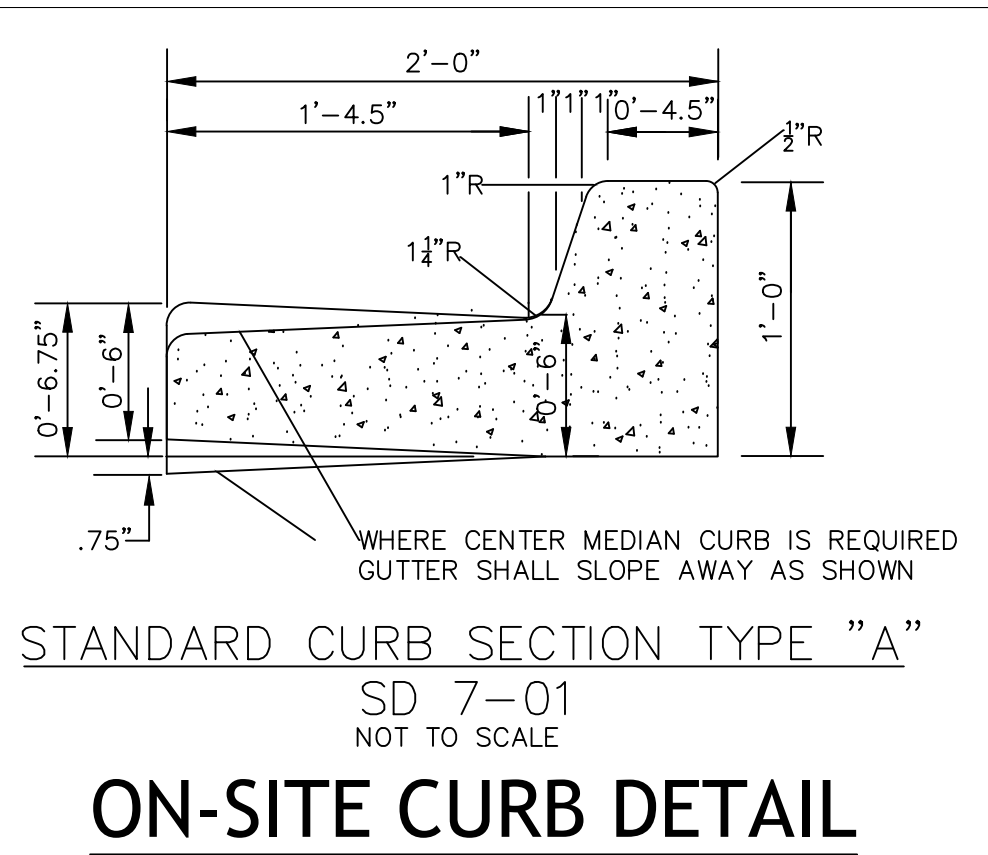

Project Number: 2014-090
 DWG Name: 2014-090 Details.dwg
 Drawing Scale: AS NOTED
 Date of Project: 10-21-2014
 Engineer of Record:
 Jason Henderson, P.E.
 South Carolina P.E. 22388
 Georgia P.E. 62071
 North Carolina P.E. 031306
 Alabama P.E. 32054

blue WATER
 civil design, PLLC
 bluewatercivil.com • info@bluewatercivil.com
 19 Washington Park Suite 100 • Greenville, SC 29601
 www.bluewatercivil.com • info@bluewatercivil.com

BRAGG ROAD DEV. COMPANY, LLC
 Bragg Drive
 Wilmington, NC

Certificates of Authorization:
 SC 04212 - GA PEF005865
 NC P0868 - AL CA4065E

Approved Construction Plan
 Name: _____
 Date: _____
 Planning: _____
 Traffic: _____
 Fire: _____

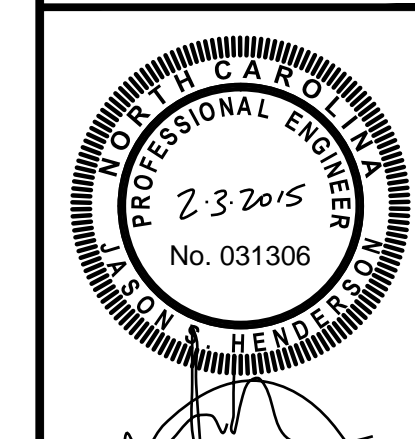

Bluewater Civil Design, PLLC
 NC-P-0868

PLAN REVISION	ISSUE DATE	ISSUE COMMENT
A	2-3-2015	ISSUED FOR PERMITS

WILMINGTON
 NORTH CAROLINA
 Public Services • Engineering Division
 APPROVED STORMWATER MANAGEMENT PLAN
 Date: _____ Permit # _____
 Signed: _____

NOTES & DETAILS

C507

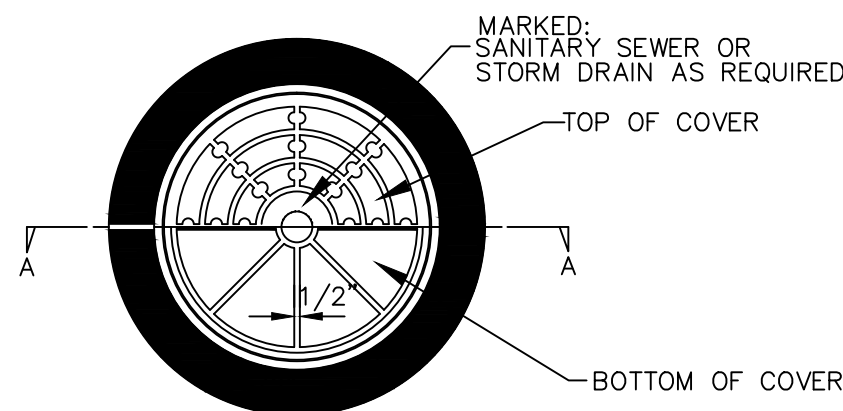

PLAN

NOTE:
RING & COVER CONTACT SURFACES SHALL BE MACHINED SO AS TO INSURE EVEN BEARING OF COVER ON RING

MINIMUM WEIGHTS:
RING 190 LBS.
COVER 120 LBS.

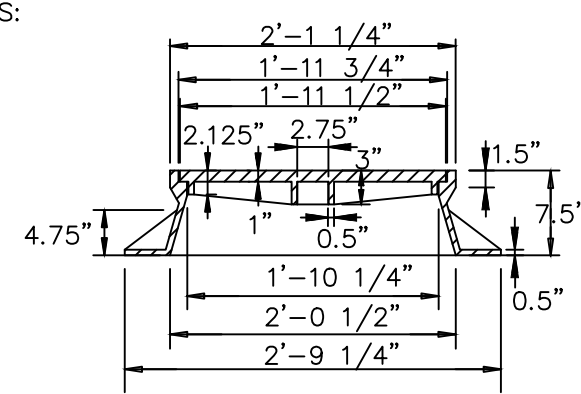

SECTION "A-A"

STANDARD MANHOLE RING AND COVER

SD 14-01

NOT TO SCALE

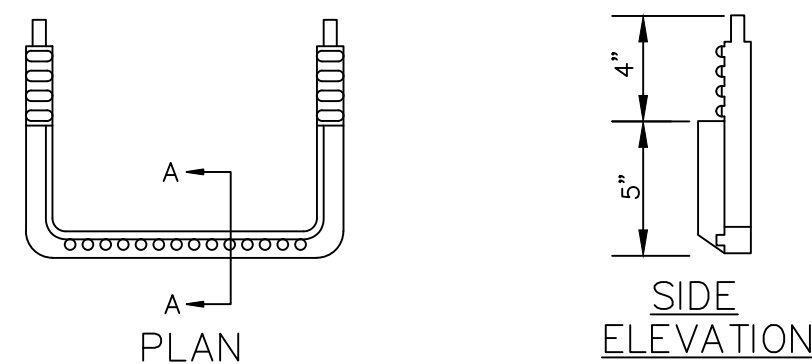

PLAN SIDE ELEVATION

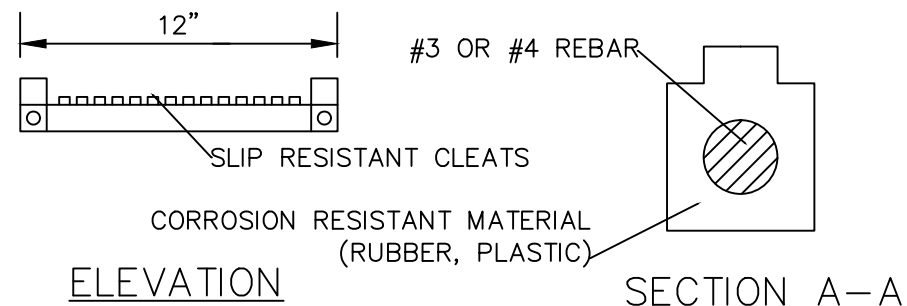

ELEVATION SECTION A-A

STANDARD SLIP RESISTANT MANHOLE STEP

SD 14-10

NOT TO SCALE

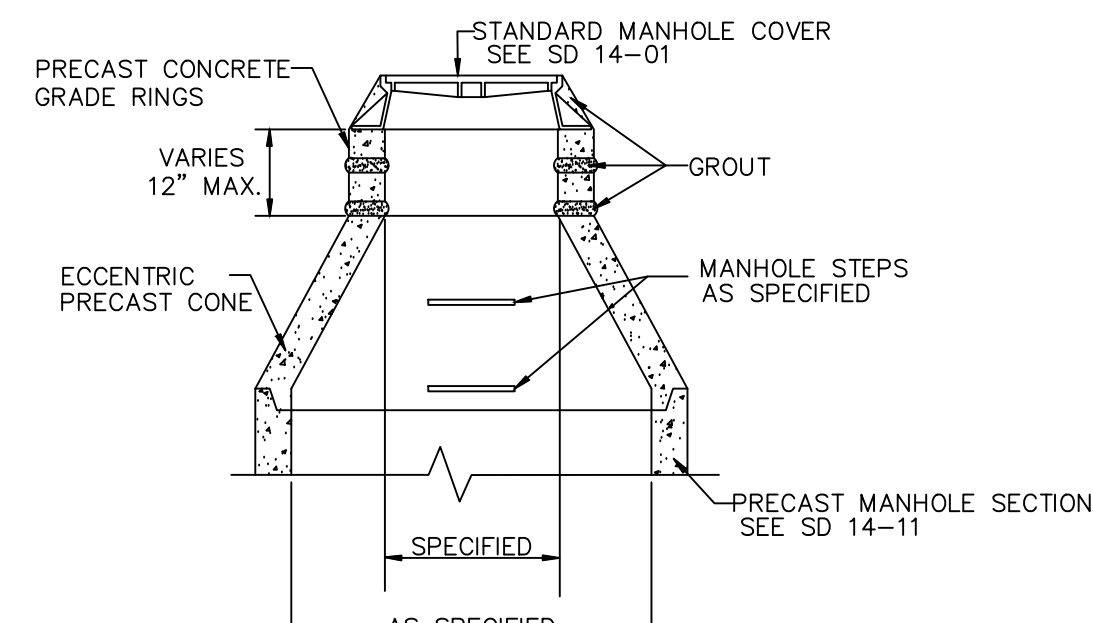

PRECAST MANHOLE RING EXTENSION

SD 14-12

NOT TO SCALE

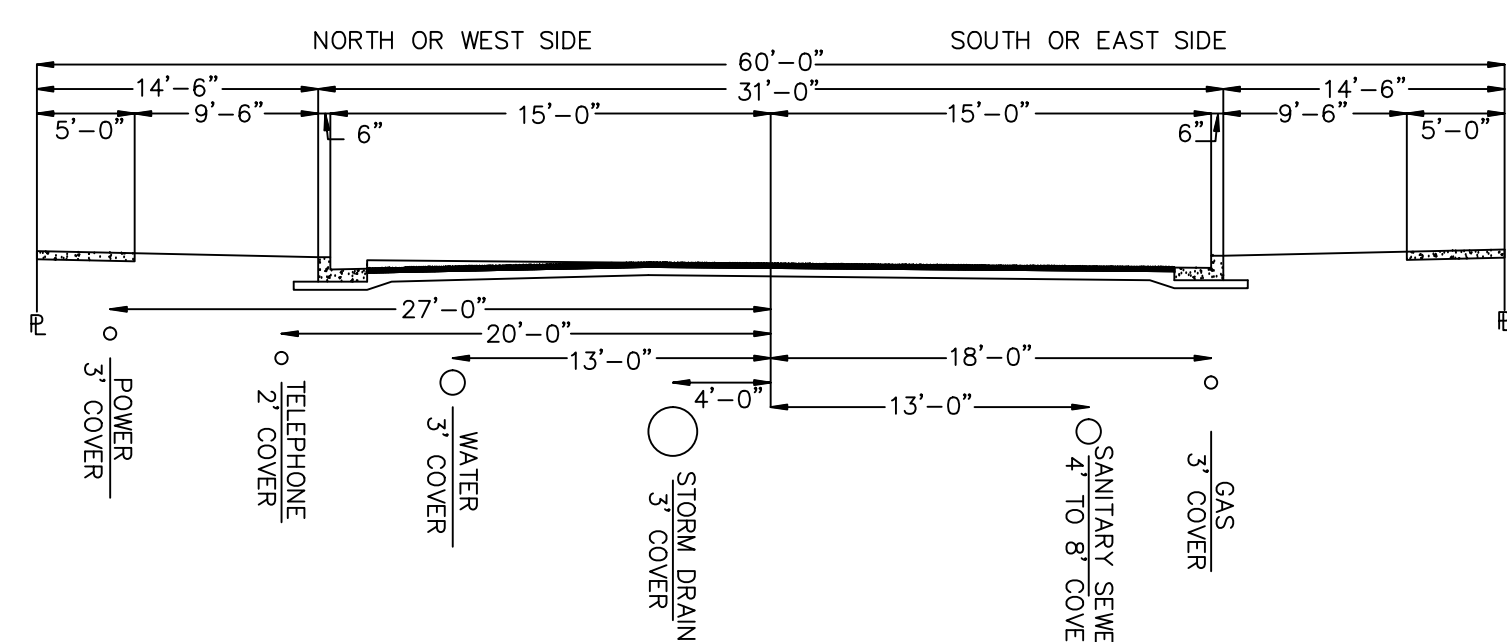

NOTE:
WHEN POSSIBLE FLUSH MOUNTED OR BELOW GROUND DISTRIBUTION OR JUNCTION BOXES TO BE USED BY UTILITIES.

STANDARD UTILITY LOCATION

SD 15-05

NOT TO SCALE

NOTE:
THE CRITICAL ROOT ZONE (CRZ) OF A TREE'S ROOTS LAY. 85% OF MOST TREE ROOTS ARE FOUND IN THE TOP 24" OF THE SOIL AND SUPPLY THE MAJORITY OF NUTRIENTS AND WATER. GENERALLY, ROOTS SPREAD OUT 2-3X THE HEIGHT OF THE TREE.

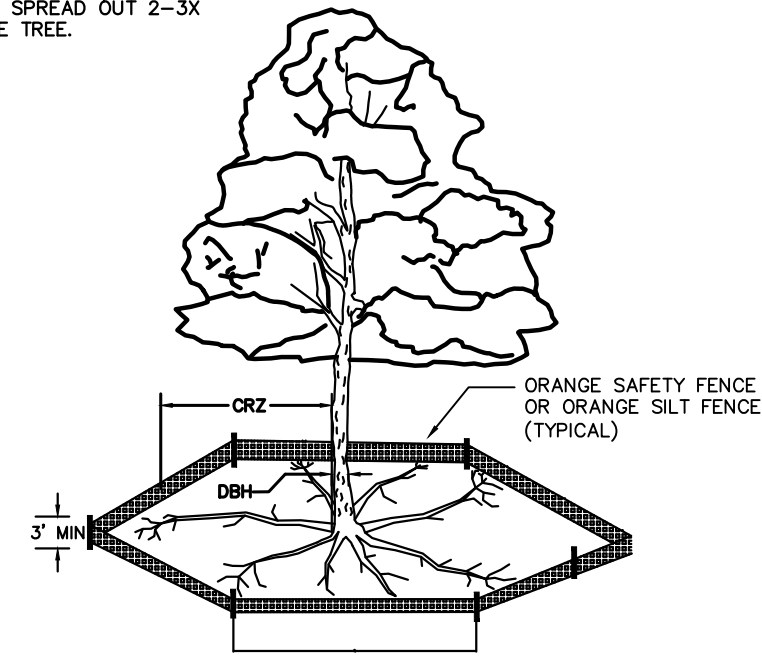

NOTES:
1. PROTECT CRITICAL ROOT ZONE (CRZ) OF TREES PRIOR TO CONSTRUCTION. CLEARLY MARK THE TREES AND ERECT A PROTECTIVE BARRIER AT THE CRZ. BARRIER SHALL BE MAINTAINED UNTIL CONSTRUCTION IS COMPLETE.
2. CRZ RADIUS IS 1 FT PER INCH OF TREE DIAMETER AT BREAST HEIGHT (DBH).
3. WHERE SIDEWALKS AND PATHWAYS PASS WITHIN CRZ, EXTRA CARE SHALL BE TAKEN TO AVOID DAMAGE TO THE ROOTS. ALTERNATE CONSTRUCTION METHODS, SUCH AS A REINFORCED SIDEWALK, SHALL BE IMPLEMENTED AS NECESSARY.
4. FOR ALL TREES, CUTTING OF LARGE STRUCTURAL ROOTS LOCATED NEAR THE BASE OF THE TRUNK IS PROHIBITED. DO NOT COMPACT SOIL BENEATH TREES. NO VEHICLE SHALL BE ALLOWED TO PARK UNDER TREES. NO HEAVY MATERIALS SHALL BE STORED BENEATH TREES. DAMAGING THE BARK WITH LAWNMOWERS, CONSTRUCTION EQUIPMENT, OR ANYTHING ELSE IS PROHIBITED. CONTRACTOR SHALL REPAIR DAMAGE TO TREES.
5. FAILING TO INSTALL OR MAINTAIN PROTECTION MEASURES MAY RESULT IN A STOP WORK ORDER AND FINE OF \$500/DAY. DISTURBANCE OTHER THAN THAT ALLOWED ON THE APPROVED PLAN WILL REQUIRE OWNER TO POST A LETTER OF CREDIT FOR 3 YRS FOR TREE MITIGATION.

DATE: NOV. 2011	DRAWN BY: JSR	CITY OF WILMINGTON ENGINEERING	SD 15-09
CHECKED BY: BDM, P.E.	SCALE: NOT TO SCALE	PO BOX 1810 WILMINGTON, NC 28402 (910) 341-7807	SHEET 1 of 2

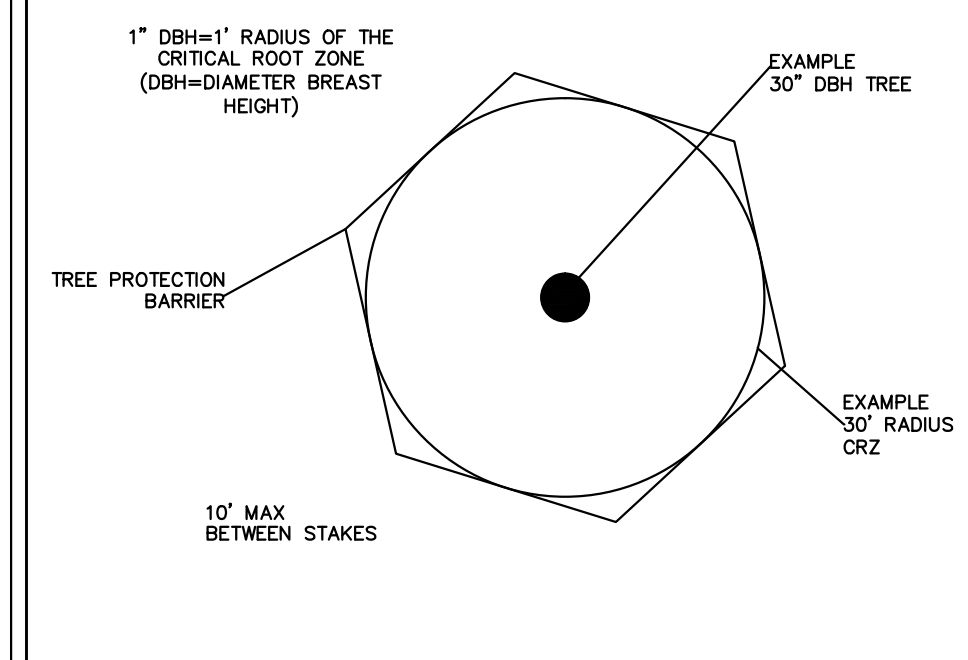

NOTE: DRAWINGS ARE NOT TO SCALE. USE AS A GUIDE FOR DETERMINING MINIMUM CRZ.

DATE: NOV. 2011	DRAWN BY: JSR	CITY OF WILMINGTON ENGINEERING	SD 15-09
CHECKED BY: BDM, P.E.	SCALE: NOT TO SCALE	PO BOX 1810 WILMINGTON, NC 28402 (910) 341-7807	SHEET 2 of 2

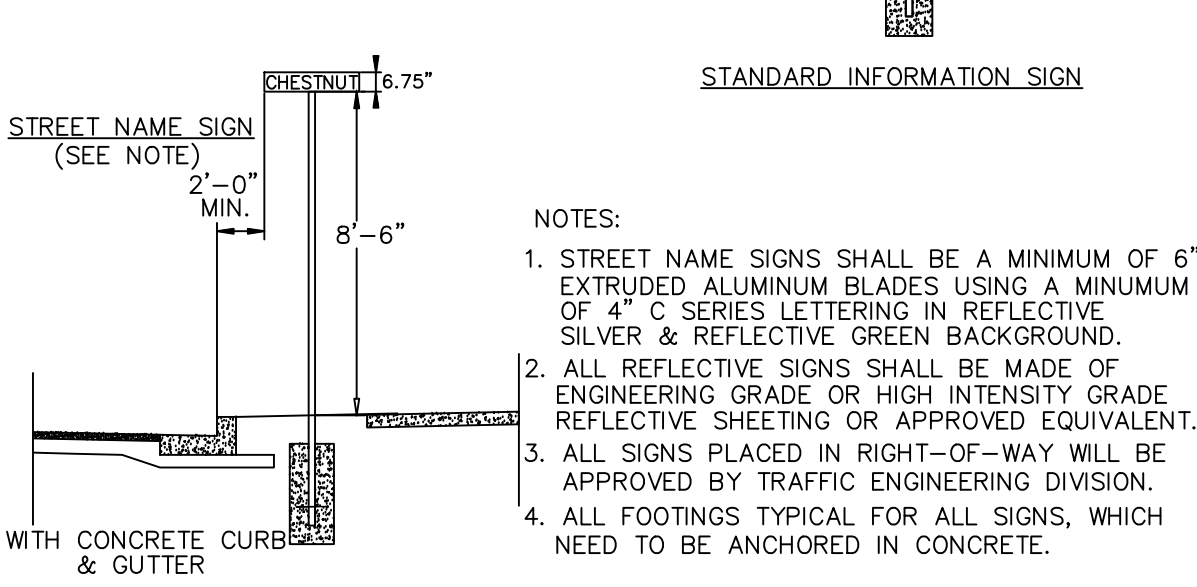
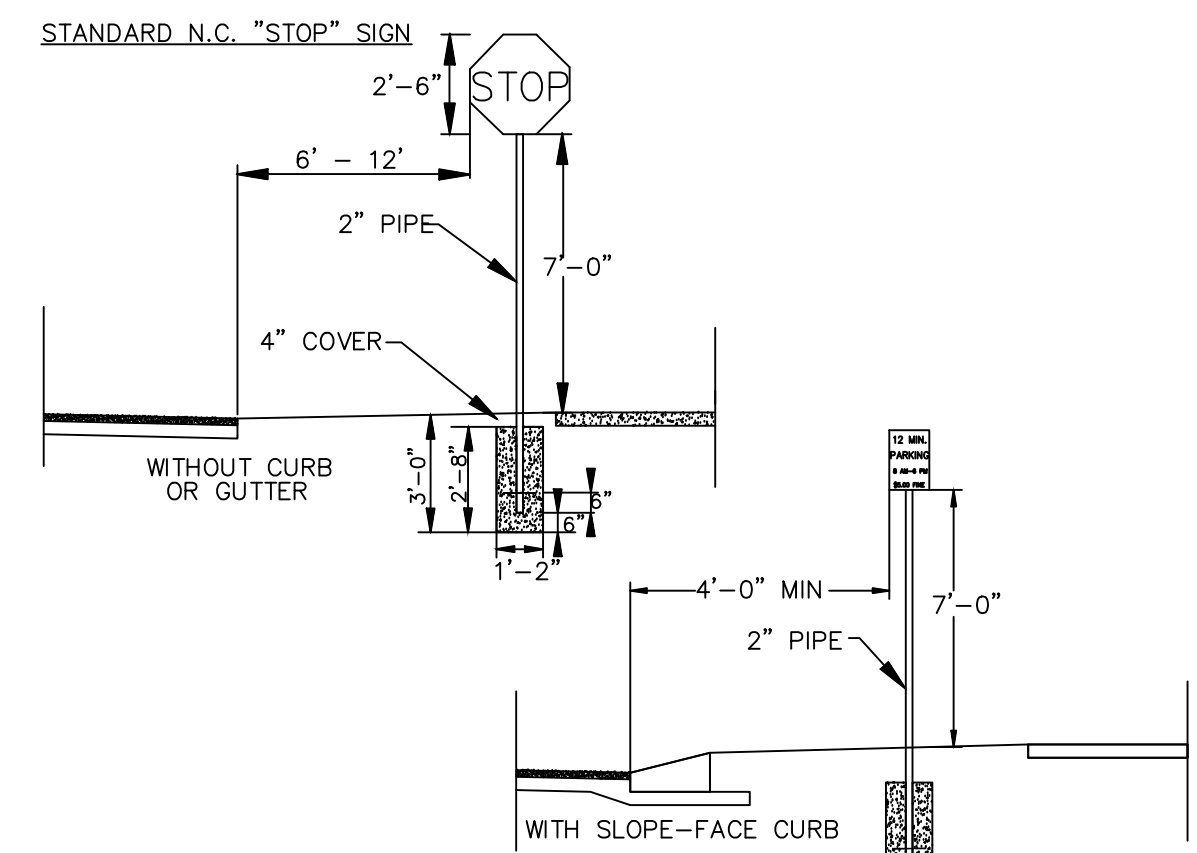

NOTES:
1. STREET NAME SIGNS SHALL BE A MINIMUM OF 6" EXTRUDED ALUMINUM BLADES USING A MINIMUM OF 4" C SERIES LETTERING IN REFLECTIVE SILVER & REFLECTIVE GREEN BACKGROUND.
2. ALL REFLECTIVE SIGNS SHALL BE MADE OF ENGINEERING GRADE OR HIGH INTENSITY GRADE REFLECTIVE SHEETING OR APPROVED EQUIVALENT.
3. ALL SIGNS PLACED IN RIGHT-OF-WAY WILL BE APPROVED BY TRAFFIC ENGINEERING DIVISION.
4. ALL FOOTINGS TYPICAL FOR ALL SIGNS, WHICH NEED TO BE ANCHORED IN CONCRETE.

STANDARD SIGN INSTALLATION LOCATION

SD 15-03

NOT TO SCALE

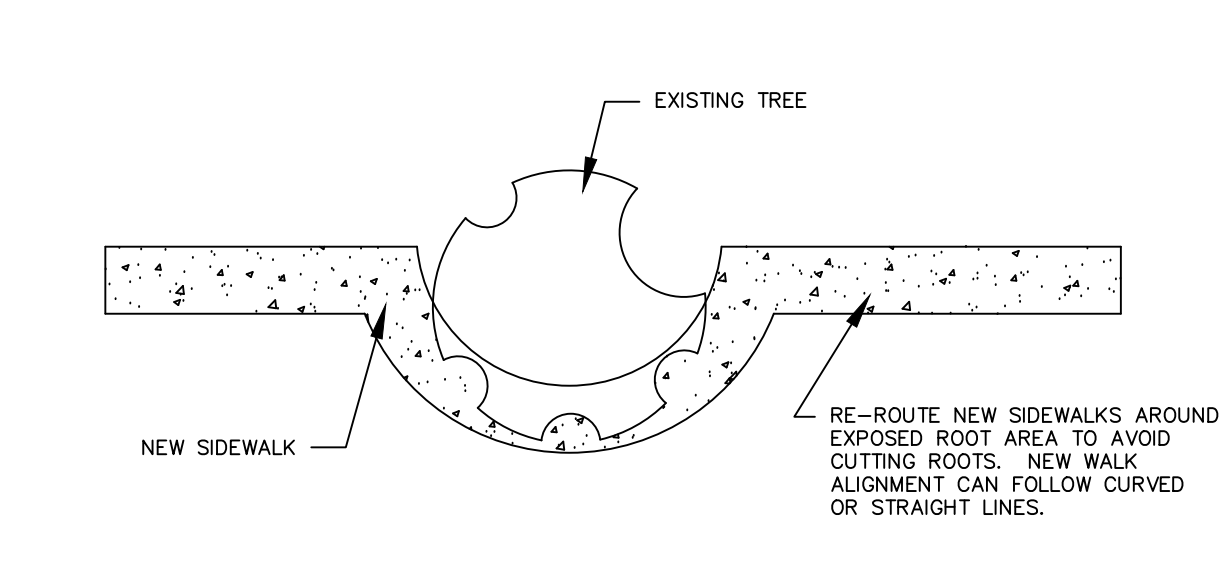
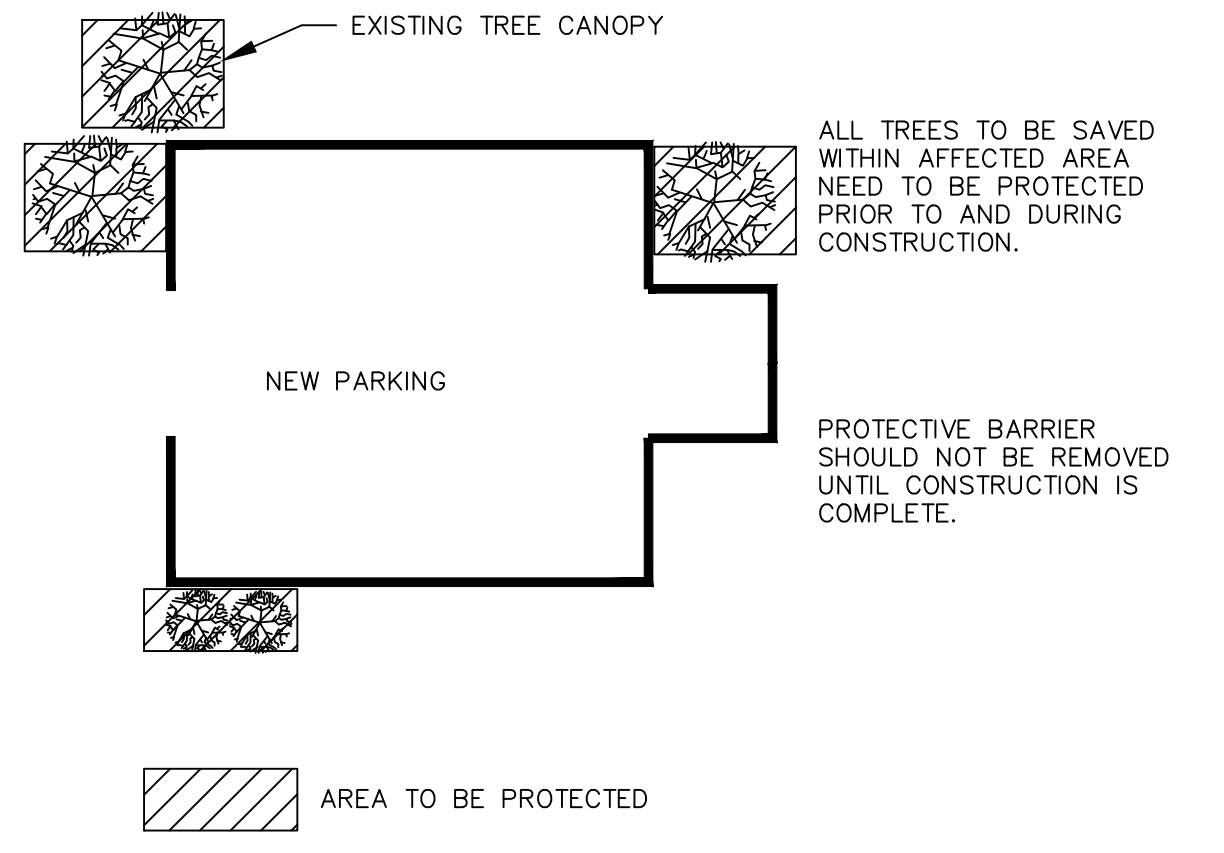

EXISTING TREE PROTECTIVE BARRIERS

SD 15-15

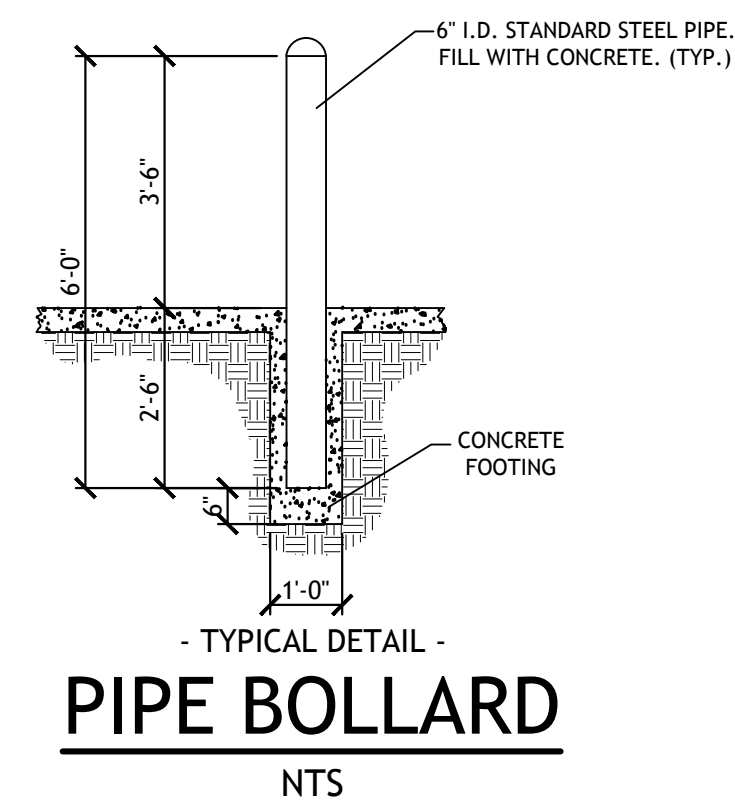

- TYPICAL DETAIL -
PIPE BOLLARD
NTS

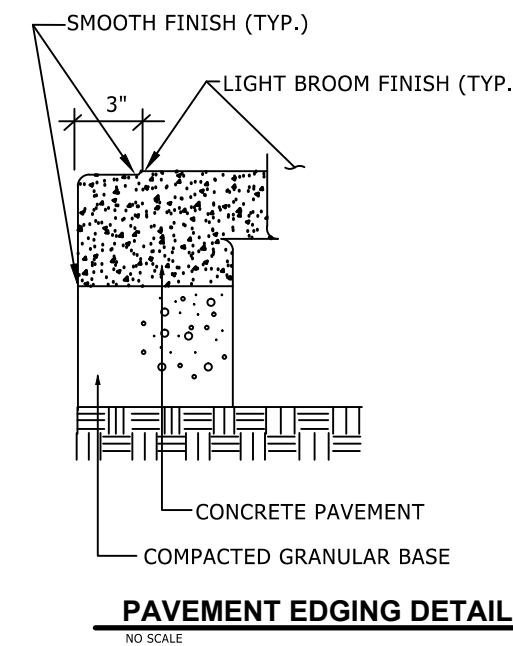

PAVEMENT EDGING DETAIL
NO SCALE

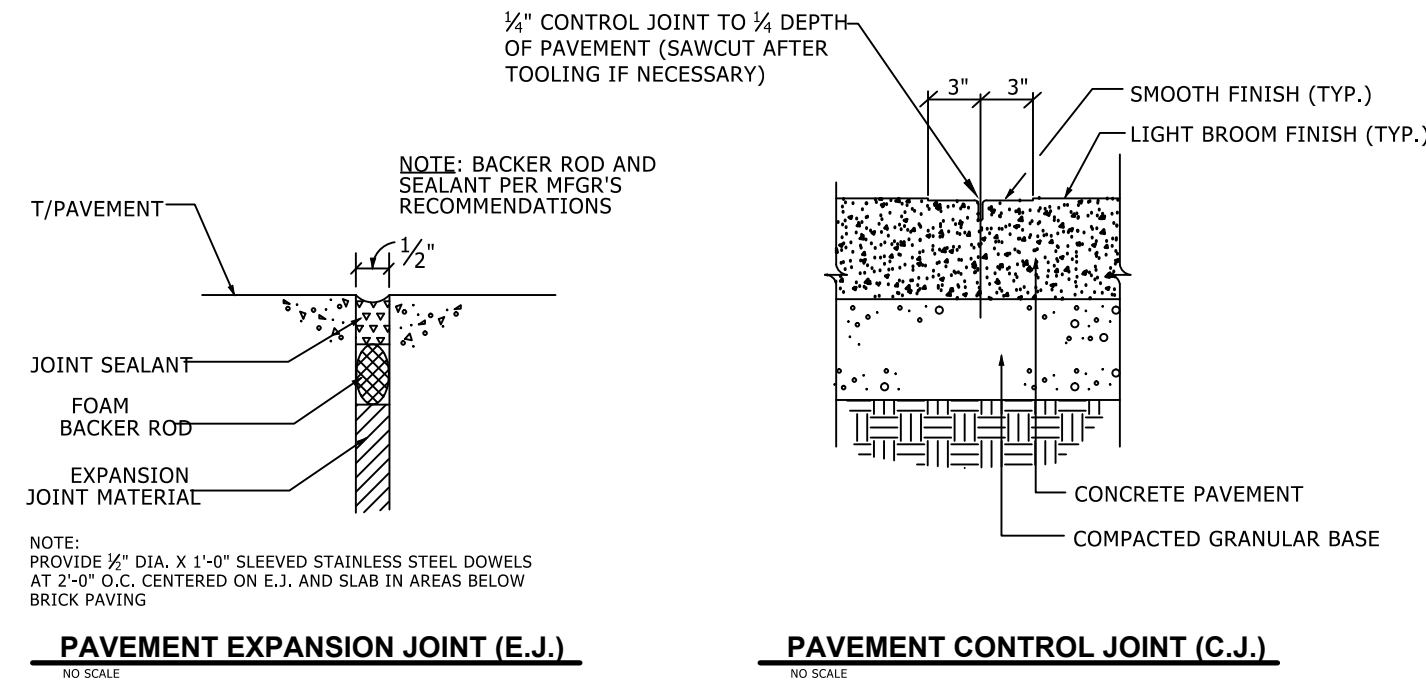

PAVEMENT CONTROL JOINT (C.J.)
NO SCALE

- TYPICAL DETAIL -
CONCRETE SIDEWALK FINISHES (ON-SITE)
NTS

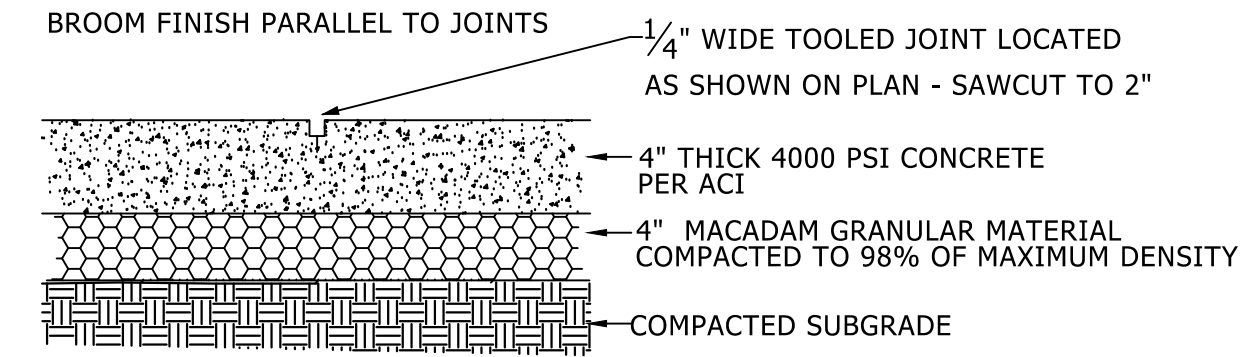

NOTES:
EXPANSION JOINTS SHALL BE INSTALLED SUCH THAT NO SINGLE DIMENSION EXCEEDS 40 FT AND ALSO AREA BETWEEN EXPANSION JOINTS NOT TO EXCEED 250 SQ.FT. SEAL ALL EXPANSION JOINTS.
1/2" EXPANSION PAPER SHALL BE PLACED AT ALL LOCATIONS THAT NEW SIDEWALK ABUTS CONCRETE CURB, EXISTING SIDEWALK, LIGHTPOLE BASES AND RETAINING WALLS.
SEAL ALL EXPANSION JOINTS.
SNAP-CAP EXPANSION JOINT STRIPS CAN BE USED ON ALL EXPANSION JOINTS.

- TYPICAL DETAIL -
CONCRETE SIDEWALK (ON-SITE)
NTS

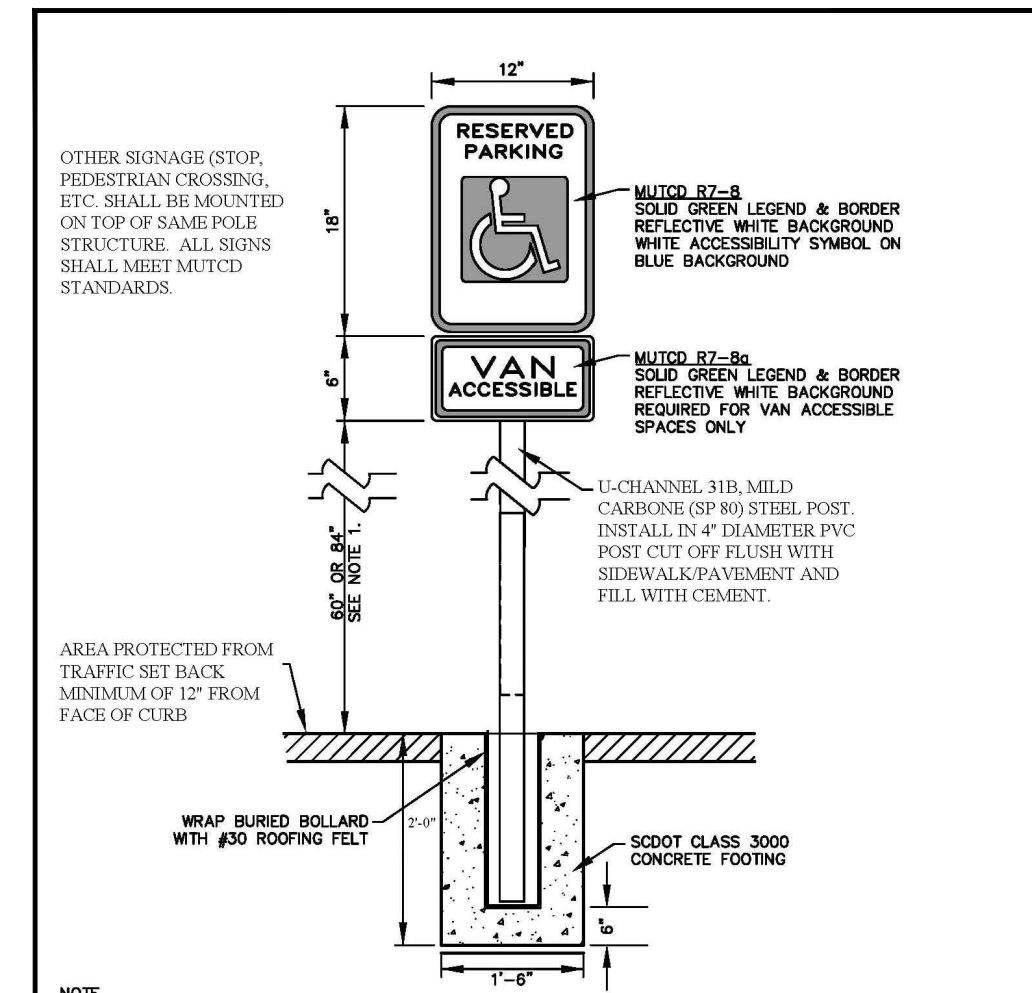

NOTE:
1. 12" x 18" ACCESSIBILITY SIGN (87-8) SHALL BE MOUNTED 7" FROM FINISH GRADE TO BOTTOM EDGE OF SIGN FACE. MOUNTING HEIGHT MAY BE REDUCED TO 5" IF PLACED IN A LANDSCAPE AREA IN WHICH PEDESTRIANS ARE NOT EXPECTED TO USE.
2. BOLLARD MAY BE OMITTED IF INSTALLED IN LANDSCAPE AREAS. WHEN INSTALLED IN LANDSCAPE AREAS, MOUNTING POST SHALL BE DESIGN A MINIMUM OF 3" BELOW FINISH GRADE. ALTERNATE MOUNTING POSTS MUST BE APPROVED BY THE CITY ENGINEER PRIOR TO CONSTRUCTION.
3. SIGNAGE SHALL BE INSTALLED IN FRONT OF EACH ACCESSIBLE SPACE, CENTERED ON THE WIDTH OF THE SPACE.
4. REFER TO AMERICANS WITH DISABILITIES ACT AND ARCHITECTURAL BARRIERS ACT ACCESSIBILITY GUIDELINES (ADAAG), LATEST EDITION, FOR REQUIRED NUMBER OF ACCESSIBLE SPACES. PER ADAAG, ONE VAN ACCESSIBLE SPACE SHALL BE PROVIDED, MINIMUM, WITH ADDITIONAL VAN ACCESSIBLE SPACES PER ADAAG REQUIREMENTS.
5. ALL SIGNAGE SHALL BE ENGINEER GRADE, .080 ALUMINUM REFLECTIVE SIGN MEETING THE REQUIREMENTS OF THE MUTCD AND ADAAG.

- TYPICAL DETAIL -
A.D.A. SIGNAGE (ON SITE)
NTS

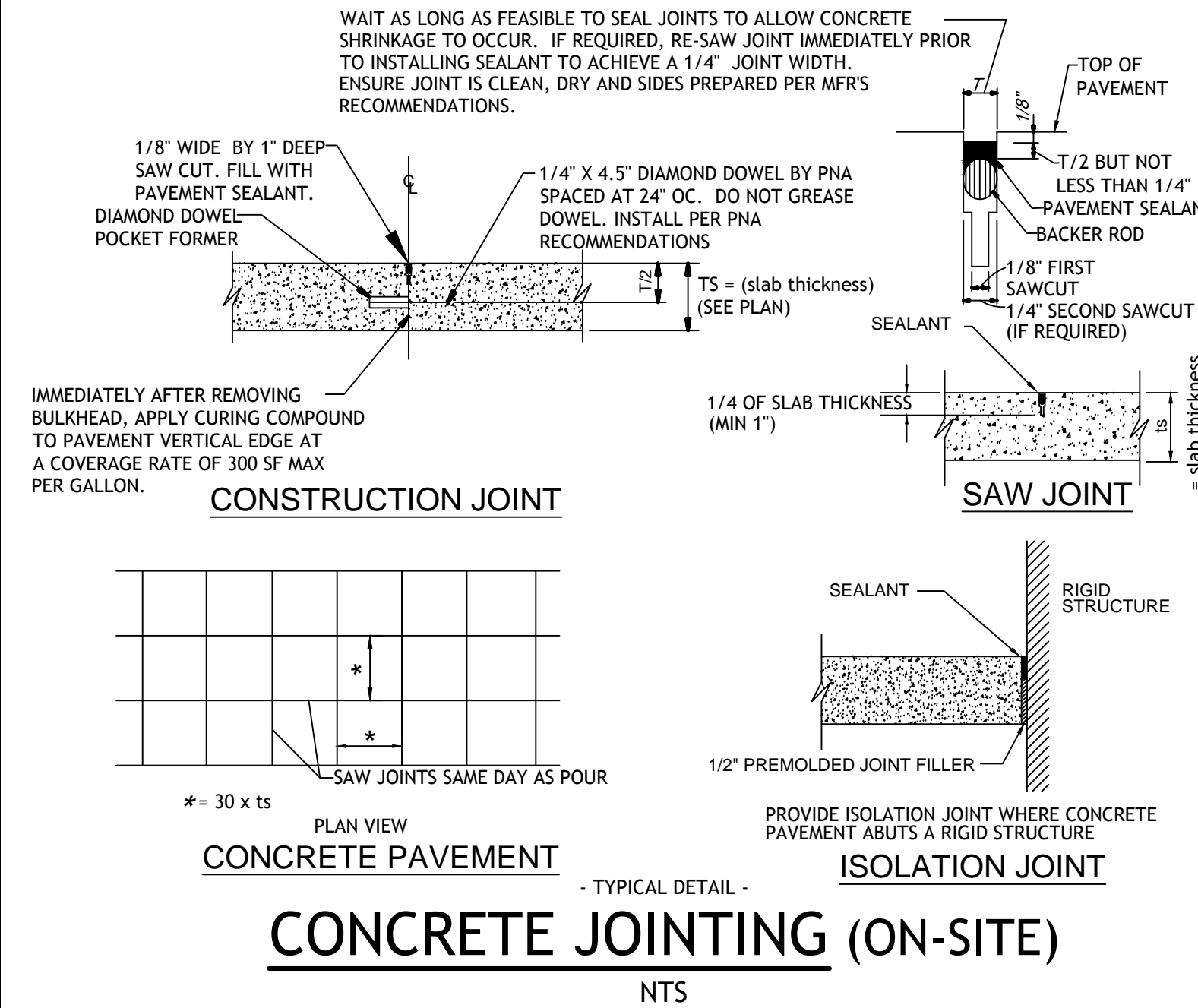

- TYPICAL DETAIL -
CONCRETE JOINTING (ON-SITE)
NTS

Approved Construction Plan
Name _____ Date _____
Planning _____ Traffic _____ Fire _____



Bluewater Civil Design, PLLC
NC-P-0868

PLAN REVISION	ISSUE DATE	ISSUE COMMENT
A	2-3-2015	ISSUED FOR PERMITS

STATE OF NORTH CAROLINA DEPT. OF TRANSPORTATION DIVISION OF HIGHWAYS RALEIGH, N.C.

ENGLISH STANDARD DRAWING FOR PROPOSED CURB AND GUTTER

CURB RAMP

ISOMETRIC VIEW

SECTION A-A

SECTION B-B

PLAN VIEW

W	A	MIN. W	X	B
6"	0.0'	5.8"	5.8'	0.0'
8"	0.0'	7.8"	7.8'	0.0'
10"	0.0'	9.8"	9.8'	0.0'
12"	0.0'	11.8"	11.8'	0.0'
14"	0.0'	13.8"	13.8'	0.0'
16"	0.0'	15.8"	15.8'	0.0'
18"	0.0'	17.8"	17.8'	0.0'
20"	0.0'	19.8"	19.8'	0.0'
22"	0.0'	21.8"	21.8'	0.0'
24"	0.0'	23.8"	23.8'	0.0'

DETECTABLE WARNING DOMES

848.05

STATE OF NORTH CAROLINA DEPT. OF TRANSPORTATION DIVISION OF HIGHWAYS RALEIGH, N.C.

ENGLISH STANDARD DRAWING FOR PROPOSED CURB AND GUTTER

CURB RAMP

DETAIL SHOWING TYPICAL LOCATION OF CURB RAMP, PEDESTRIAN CROSSWALKS AND STOP LINES FOR TEE INTERSECTIONS

DETAIL SHOWING TYPICAL LOCATION OF CURB RAMP, PEDESTRIAN CROSSWALKS AND STOP LINES

848.05

STATE OF NORTH CAROLINA DEPT. OF TRANSPORTATION DIVISION OF HIGHWAYS RALEIGH, N.C.

ENGLISH STANDARD DRAWING FOR CURB RAMPS

NOTES:

- CONSTRUCT THE RAMP SURFACE TO BE STABLE, FIRM, AND SLIP RESISTANT. CONSTRUCT THE CURB RAMP TYPE AS SHOWN IN THE PAVEMENT MARKING PLANS OR AS DIRECTED BY THE ENGINEER.
- LOCATE CURB RAMPS AND PLACE PEDESTRIAN CROSSWALK MARKINGS AS SHOWN IN THE PAVEMENT MARKING PLANS. WHEN FIELD ADJUSTMENTS REQUIRE MOVING CURB RAMPS OR MARKINGS AS SHOWN, CONTACT THE SIGNING AND DELINEATION UNIT OR LOCATE AS DIRECTED BY THE ENGINEER.
- COORDINATE THE CURB RAMP AND THE PEDESTRIAN CROSSWALK MARKINGS SO A 4'x4' CLEAR SPACE AT THE BASE OF THE CURB RAMP WILL FALL WITHIN THE PEDESTRIAN CROSSWALK LINES.
- SET BACK DISTANCE FROM INSIDE CROSSWALK MARKING TO NEAREST EDGE OF TRAVEL LANE IS 4' MINIMUM.
- REFER TO THE PAVEMENT MARKING PLANS FOR STOP BAR LOCATIONS AT SIGNALIZED INTERSECTIONS. IF A PAVEMENT MARKING PLAN IS NOT PROVIDED, CONTACT THE SIGNAL DESIGN SECTION FOR THE STOP BAR LOCATIONS OR LOCATE AS DIRECTED BY THE ENGINEER.
- TERMINATE PARKING A MINIMUM OF 20' BACK OF A PEDESTRIAN CROSSWALK.
- CONSTRUCT CURB RAMPS A MINIMUM OF 4' WIDE.
- CONSTRUCT THE RUNNING SLOPE OF THE RAMP 0.33% MAXIMUM.
- ALLOWABLE CROSS SLOPE ON SIDEWALKS AND CURB RAMPS WILL BE 2% MAXIMUM.
- CONSTRUCT THE SIDE FLARE SLOPE A MAXIMUM OF 10% MEASURED ALONG THE CURB LINE.
- CONSTRUCT THE COUNTER SLOPE OF THE GUTTER OR STREET AT THE BASE OF THE CURB RAMP A MAXIMUM OF 5% AND MAINTAIN A SMOOTH TRANSITION.
- CONSTRUCT LANDINGS FOR SIDEWALK A MINIMUM OF 4'x4' WITH A MAXIMUM SLOPE OF 2% IN ANY DIRECTION. CONSTRUCT LANDINGS FOR MEDIAN ISLANDS A MINIMUM OF 5'x5' WITH A MAXIMUM SLOPE OF 2% IN ANY DIRECTION.
- TO USE A MEDIAN ISLAND AS A PEDESTRIAN REFUGE AREA, MEDIAN ISLANDS WILL BE A MINIMUM OF 6' WIDE. CONSTRUCT MEDIAN ISLANDS TO PROVIDE PASSAGE OVER OR THROUGH THE ISLAND.
- SMALL CHANNELIZATION ISLANDS THAT CAN NOT PROVIDE A 5'x5' LANDING AT THE TOP OF A RAMPS, WILL BE CUT THROUGH LEVEL WITH THE SURFACE STREET.
- CURB RAMPS WITH RETURNED CURBS MAY BE USED ONLY WHERE PEDESTRIANS WOULD NOT NORMALLY WALK ACROSS THE RAMP. THE ADJACENT SURFACE IS PLANTING OR OTHER NON-WALKING SURFACE OR THE SIDE APPROACH IS SUBSTANTIALLY OBSTRUCTED.
- PLACE A 1/2" EXPANSION JOINT WHERE THE CONCRETE CURB RAMP JOINS THE CURB AS SHOWN IN ROADWAY STANDARD DRAWING 848.01
- PLACE ALL PEDESTRIAN PUSH BUTTON ACTUATORS AND CROSSING SIGNALS AS SHOWN IN THE PLANS OR AS SHOWN IN THE MUTCD.
- CURB RAMPS THROUGH MEDIAN ISLANDS, SINGLE RAMPS AT DUAL CROSSWALKS OR LIMITED R/W SITUATIONS, WILL BE HANDLED BY SPECIAL DETAILS. CONTACT THE CONTRACT STANDARDS AND DEVELOPMENT UNIT FOR THE DETAILS OR FOR A SPECIAL DESIGN.

848.05

STATE OF NORTH CAROLINA DEPT. OF TRANSPORTATION DIVISION OF HIGHWAYS RALEIGH, N.C.

ENGLISH STANDARD DRAWING FOR METHOD OF PIPE INSTALLATION

FLEXIBLE PIPE

PIPE IN TRENCH

PIPE ABOVE GROUND

848.05

STATE OF NORTH CAROLINA DEPT. OF TRANSPORTATION DIVISION OF HIGHWAYS RALEIGH, N.C.

ENGLISH STANDARD DRAWING FOR METHOD OF PIPE INSTALLATION

RIGID PIPE

PIPE IN TRENCH

PIPE ABOVE GROUND

848.05

STATE OF NORTH CAROLINA DEPT. OF TRANSPORTATION DIVISION OF HIGHWAYS RALEIGH, N.C.

ENGLISH STANDARD DRAWING FOR PAVEMENT MARKINGS

LINE TYPES AND OFFSETS

CONTINUOUS LINES

10'-30'/SP SKIP LINE

2'-6'/SP MINI-SKIP LINE

3'-3'/SP MINI-SKIP LINE

3'-9'/SP MINI-SKIP LINE

848.05

Project Number: 2014-090
DWG Name: 2014-090 Details.dwg
Drawing Scale: AS NOTED
Date of Project: 10-21-2014
Engineer of Record: Jason Henderson, P.E.
South Carolina PEF 2258
Georgia PEF 62071
North Carolina PEF 03136
Alabama PEF 32054
www.bluewatercivil.com • info@bluewatercivil.com
19 Washington Park Suite 100 • Greenville, SC 29601

BRAGG ROAD DEV. COMPANY, LLC
Bragg Drive
Wilmington, NC

Approved Construction Plan
Name _____
Date _____
Planning _____
Traffic _____
Fire _____

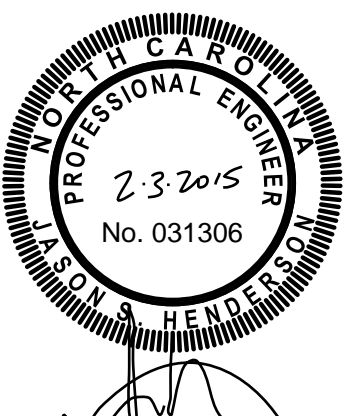

Bluewater Civil Design, PLLC
NCP-0868

PLAN REVISION	ISSUE DATE	ISSUE COMMENT
A	2-3-2015	ISSUED FOR PERMITS

NOTES & DETAILS

APPROVED STORMWATER MANAGEMENT PLAN

Date: _____ Permit # _____

Signed: _____

C511

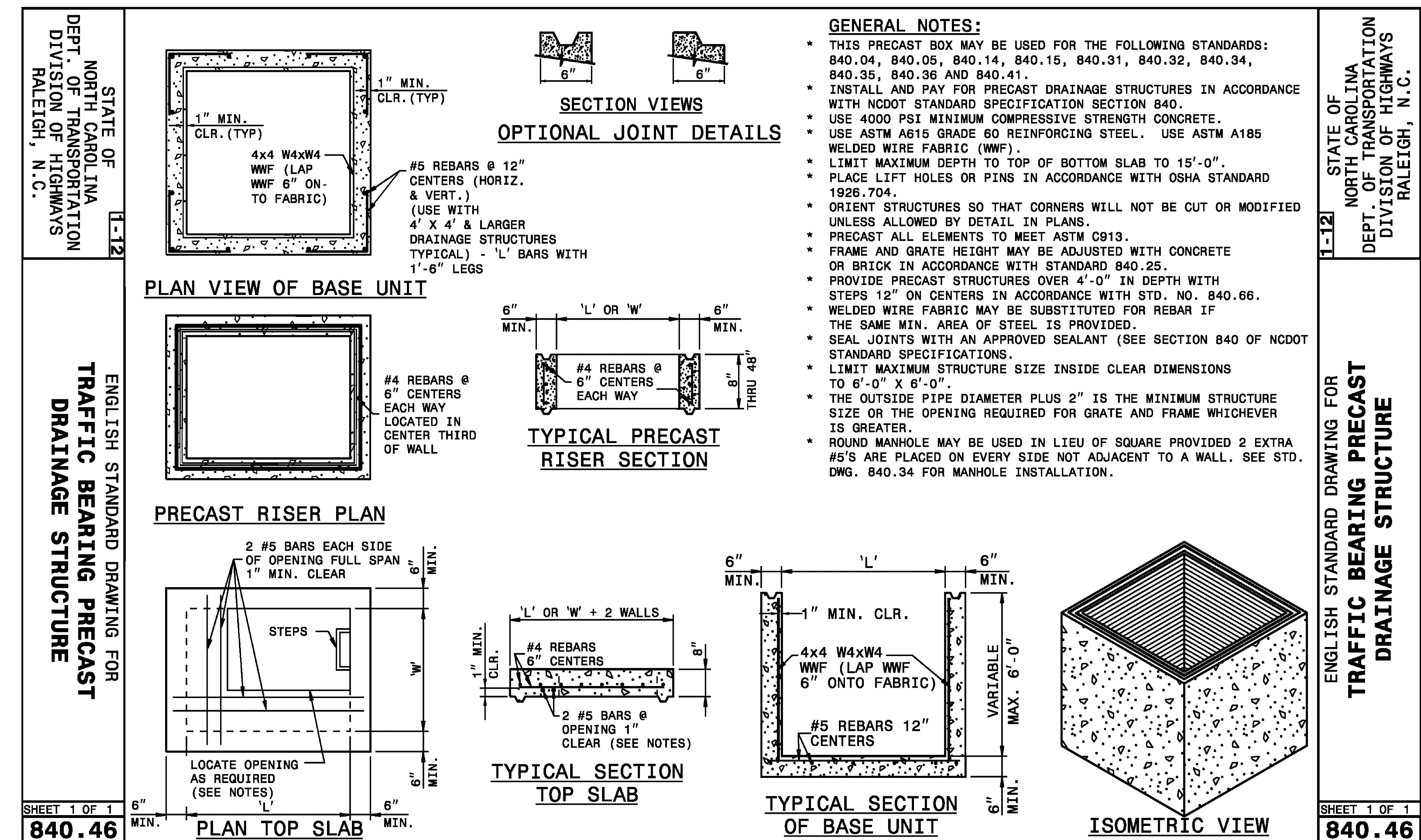
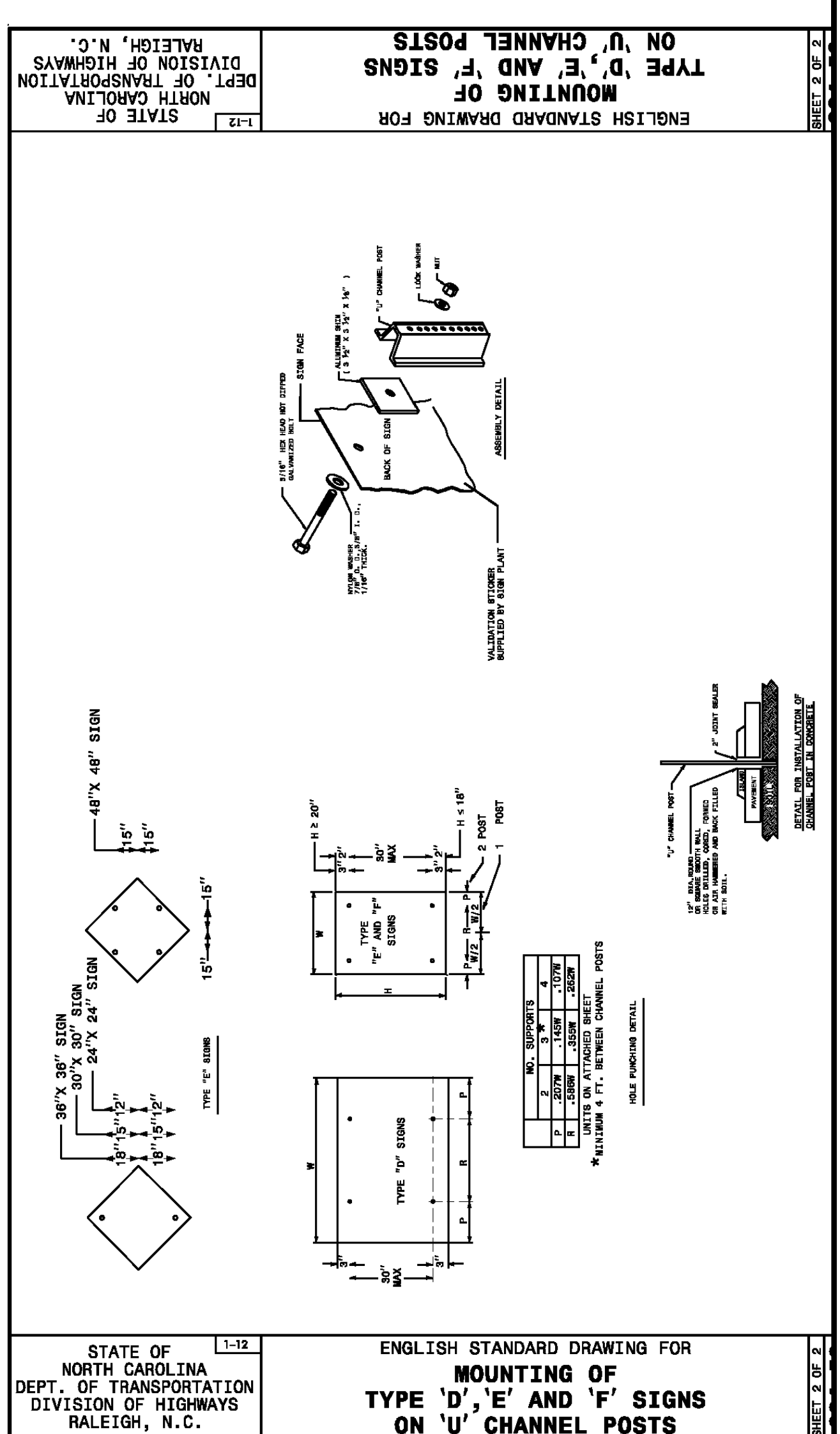
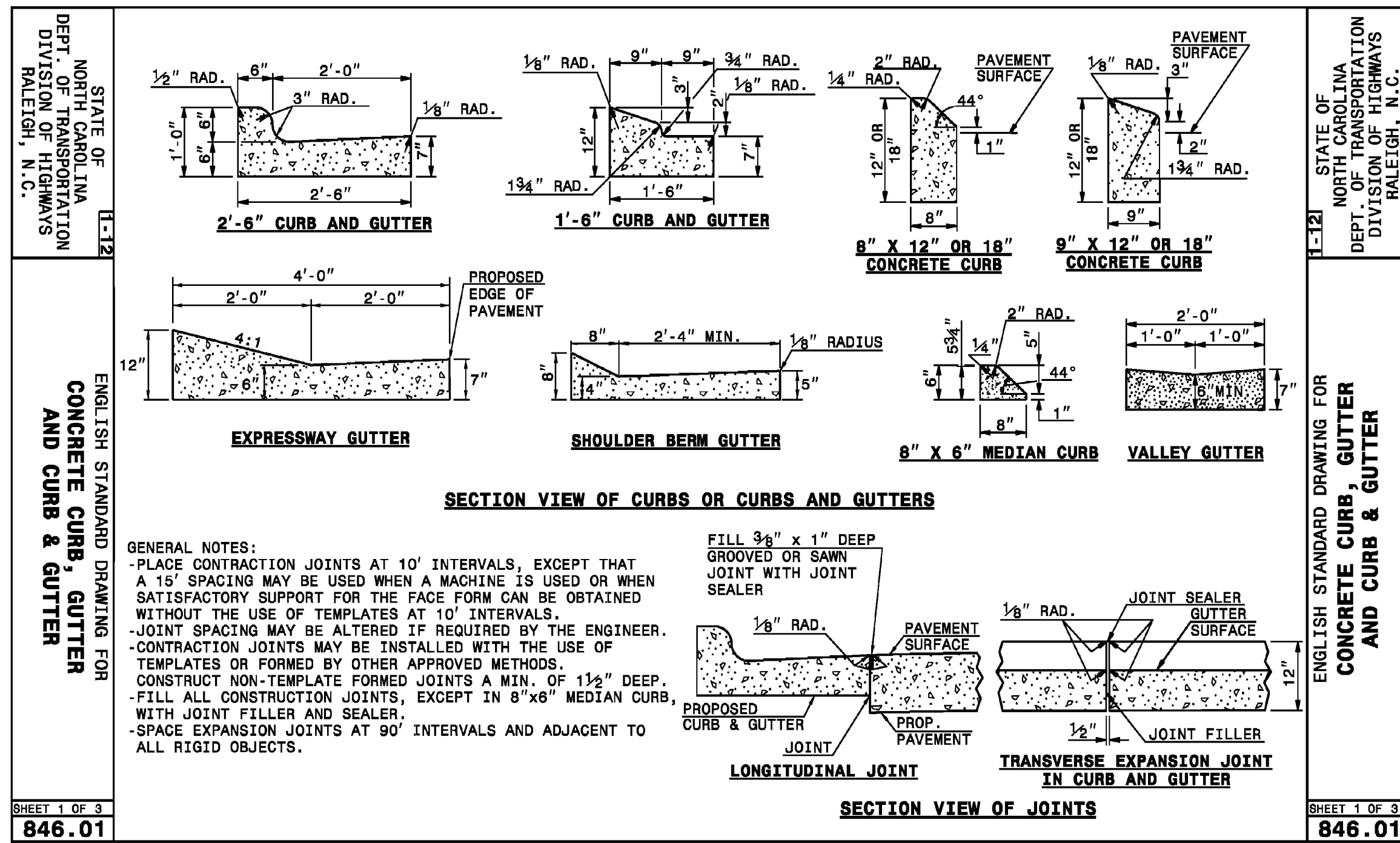
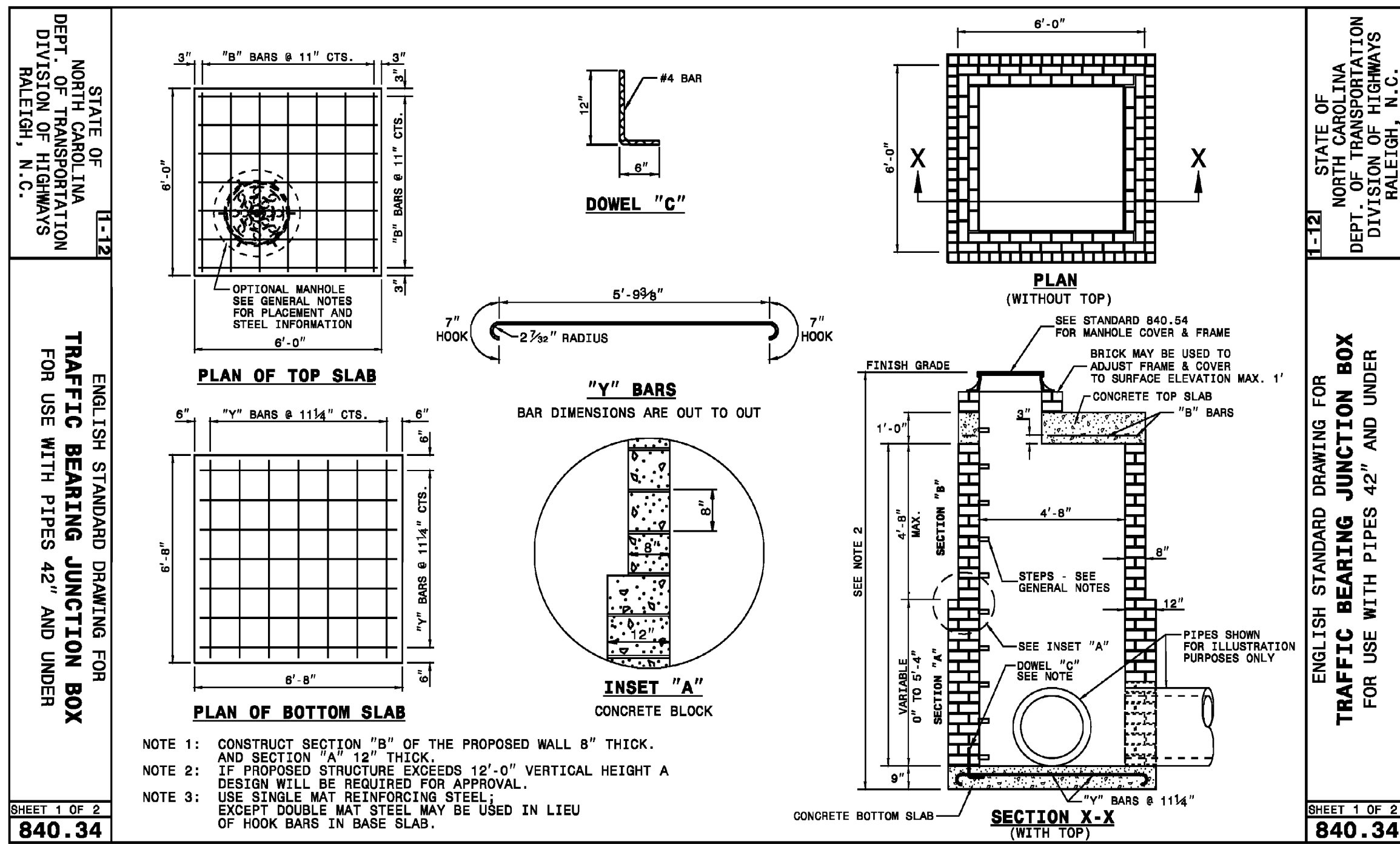

Project Number: 2014-090
 DWG Name: 2014-090 Details.dwg
 Drawing Scale: AS NOTED
 Date of Project: 10-21-2014
 Engineer of Record:
 Jason Henderson, P.E.
 South Carolina P.E. 22806
 Georgia P.E. 62071
 North Carolina P.E. 031306
 Alabama P.E. 32054

bluewater civil design, PLLC
 bluewatercivil.com • info@bluewatercivil.com
 19 Washington Park Suite 100 • Greenville, SC 29601

Certificates of Authorization:
 SC C04212 - GA PEF005865
 NC P0868 - AL CA40656

BRAGG ROAD DEV. COMPANY, LLC
 Bragg Drive
 Wilmington, NC

Approved Construction Plan
 Name: _____ Date: _____
 Planning: _____ Traffic: _____
 Fire: _____

PROFESSIONAL ENGINEER
 JASON HENDERSON
 No. 031306

Bluewater Civil Design, PLLC
 NC P-0868

REVISION	ISSUE DATE	ISSUE COMMENT
A	2-3-2015	ISSUED FOR PERMITS

NOTES & DETAILS

C513

Signed: _____

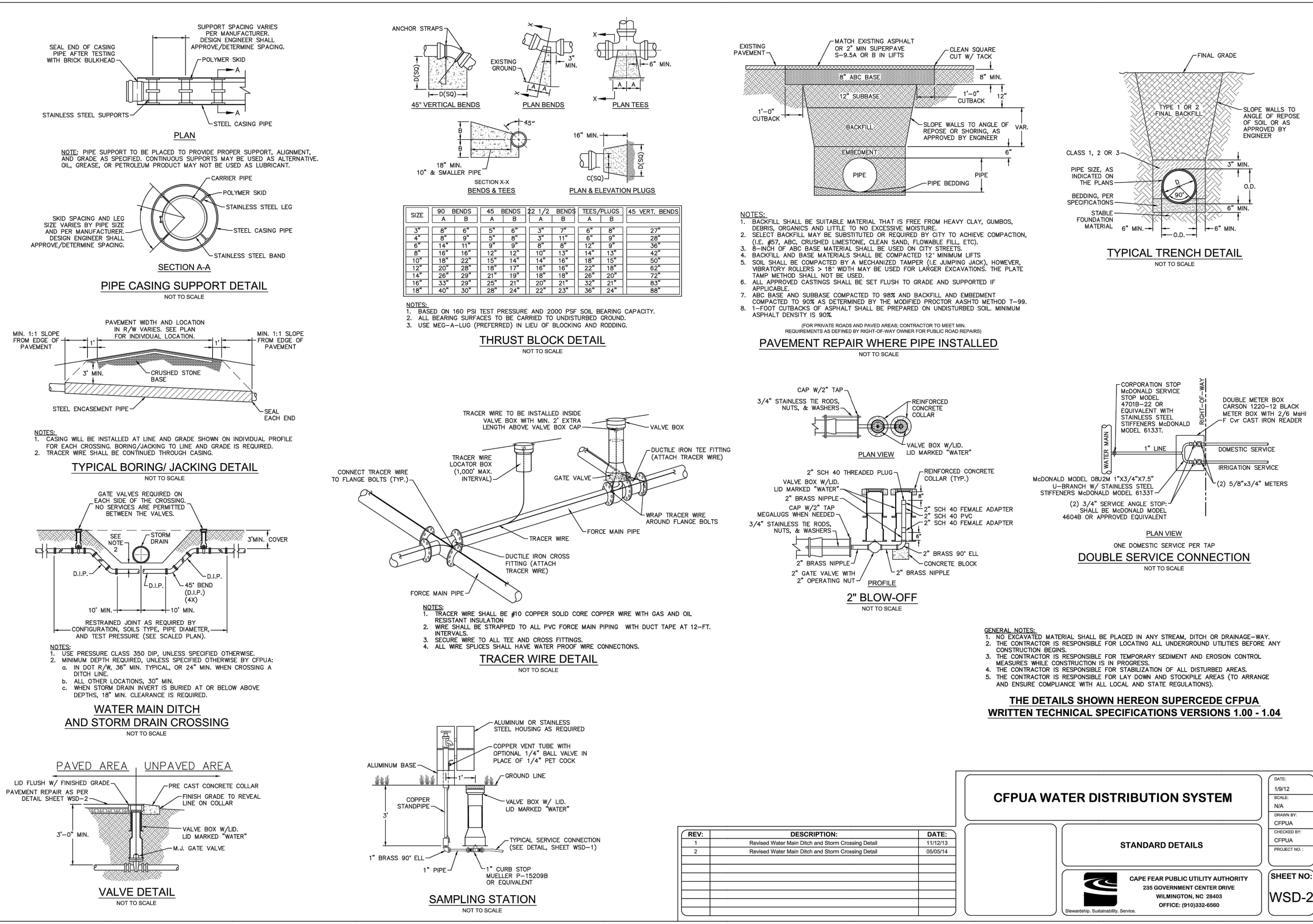
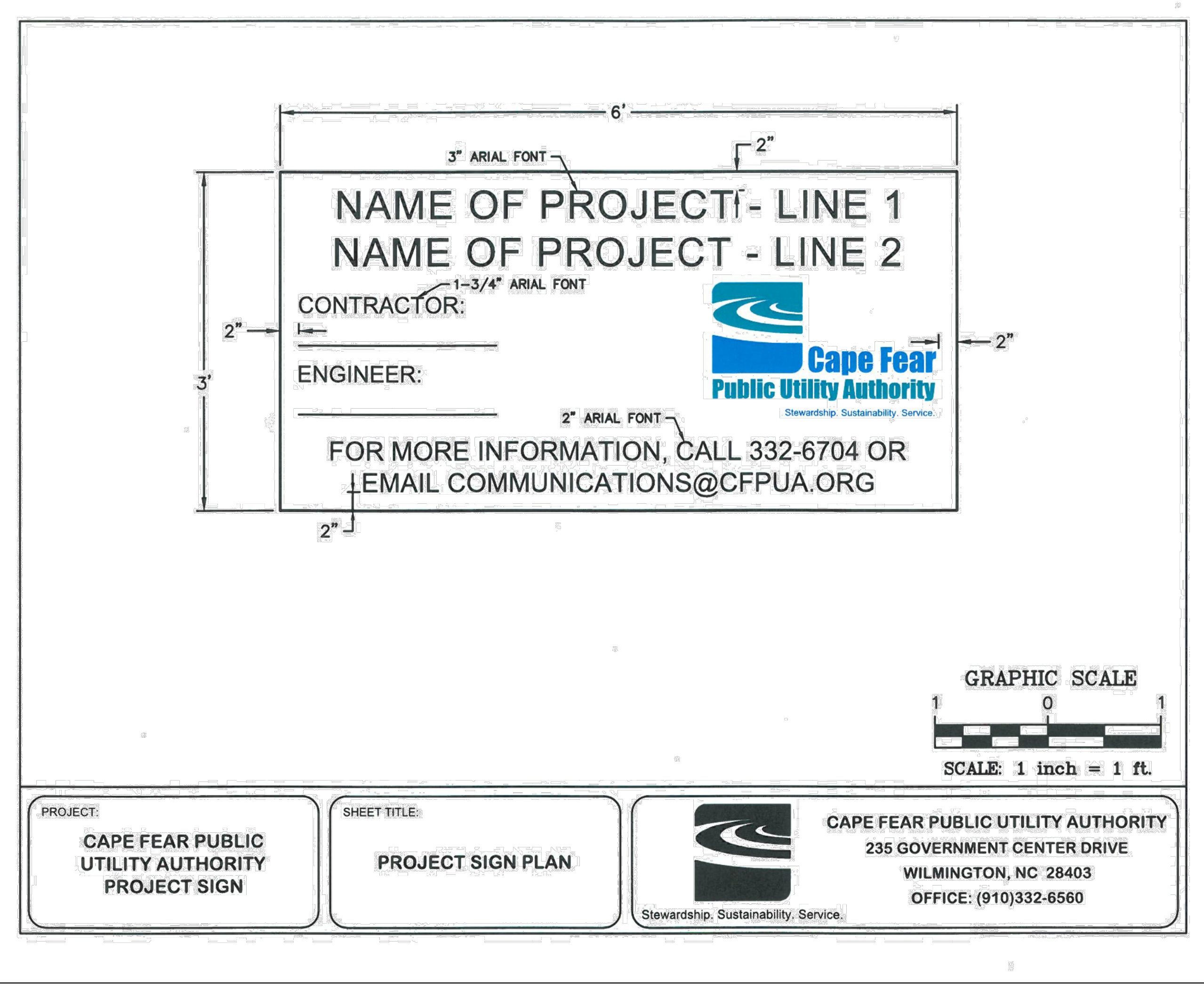
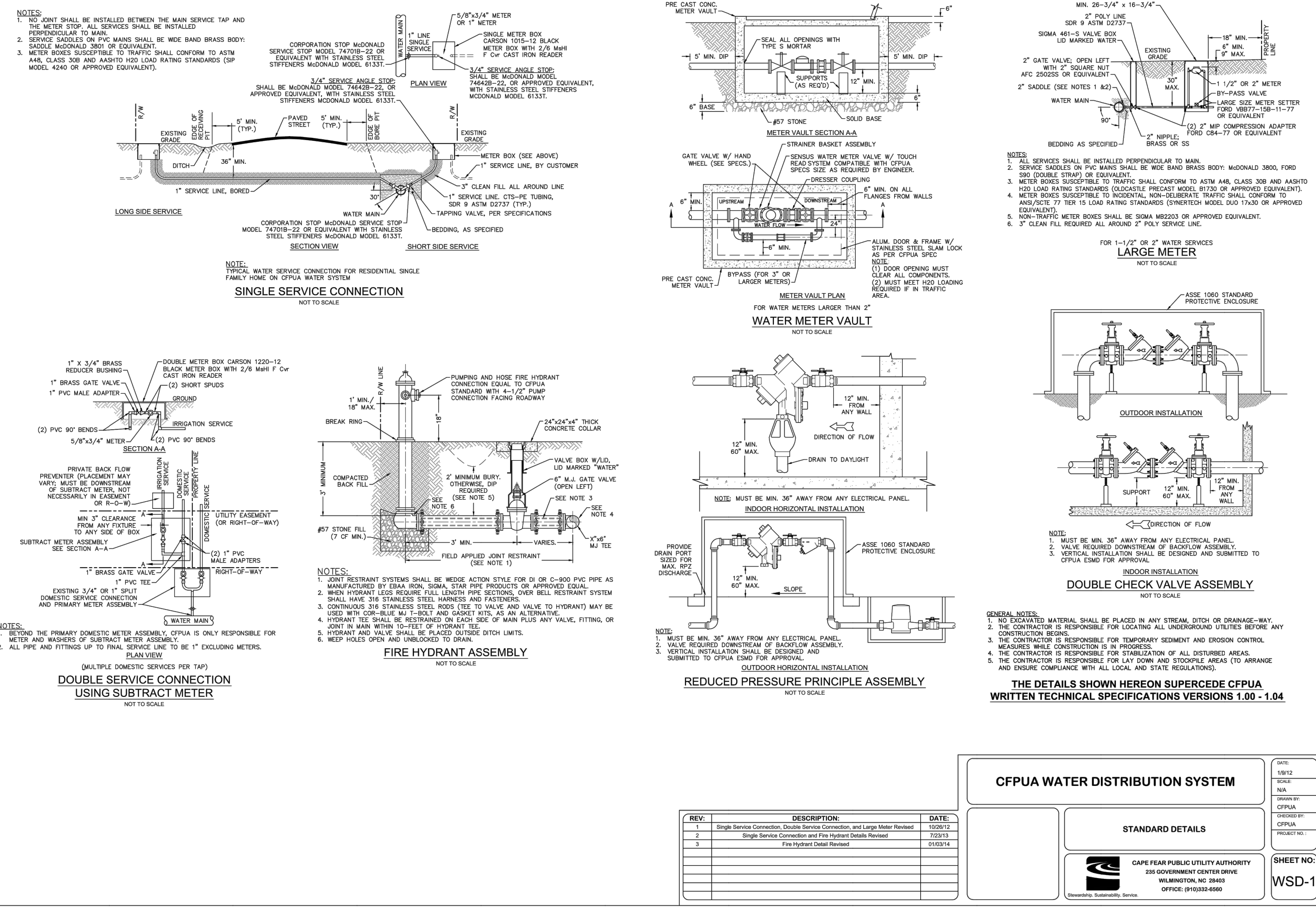

Project Number: 2014-090
DWG Name: 2014-090 Details.dwg
Drawing Scale: as noted
Date of Project: 10-21-2014
Engineer of Record: Jason Henderson, P.E.
South Carolina P.E. 22406
Georgia P.E. 62071
North Carolina P.E. 031306
Alabama P.E. 32054

bluewater civil design, PLLC
bluewatercivil.com • info@bluewatercivil.com
19 Washington Park Suite 100 • Greenville, SC 29601
www.bluewatercivil.com

Certificates of Authorization:
SC 02412 - GA PEF005865
NC P0688 - AL CA4065E

BRAGG ROAD DEV. COMPANY, LLC
Bragg Drive
Wilmington, NC

Approved Construction Plan
Name: _____
Date: _____
Planning: _____
Traffic: _____
Fire: _____

PROFESSIONAL ENGINEER
JASON HENDERSON
No. 031306
2-3-2015

Bluewater Civil Design, PLLC
NC-P-0868

PLAN REVISION	ISSUE DATE	ISSUE COMMENT
A	2-3-2015	ISSUED FOR PERMITS

NOTES & DETAILS

C514

Date: _____ Permit # _____
Signed: _____

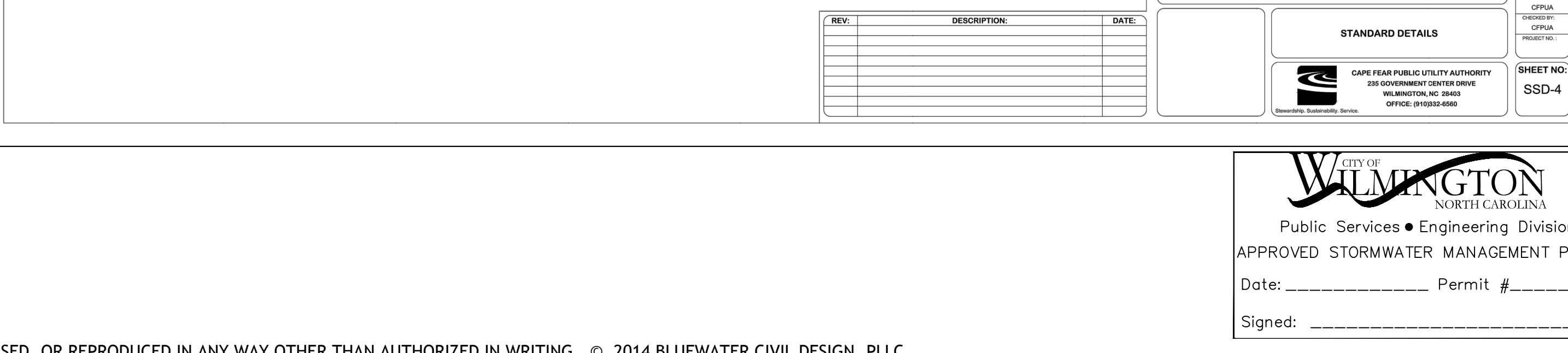
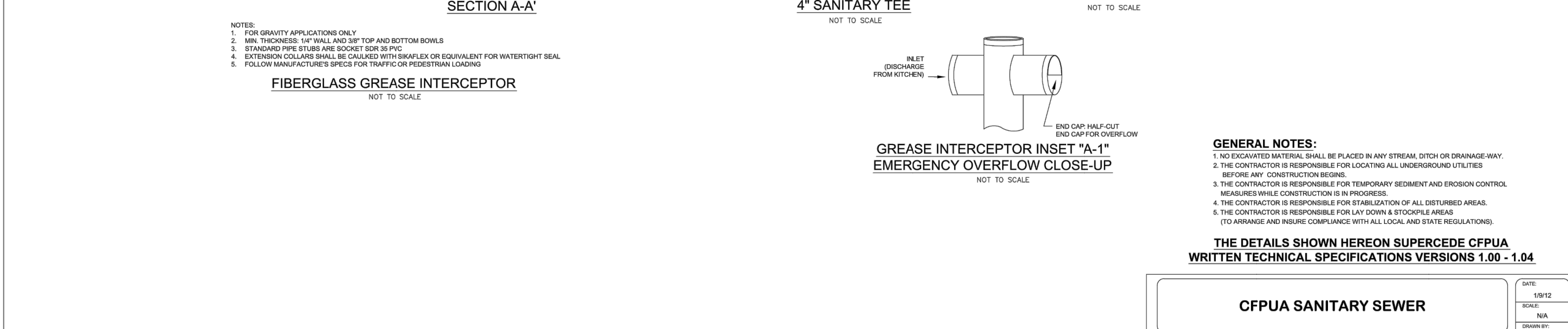
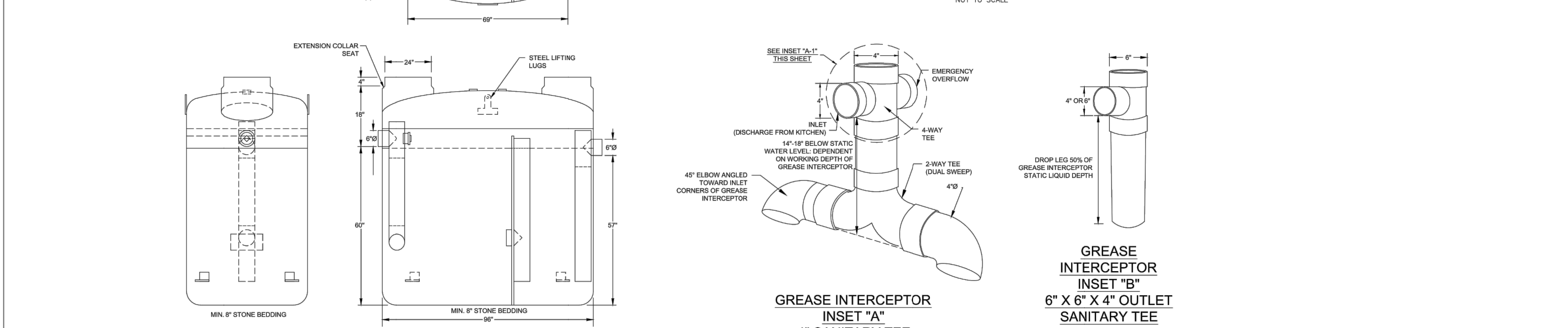
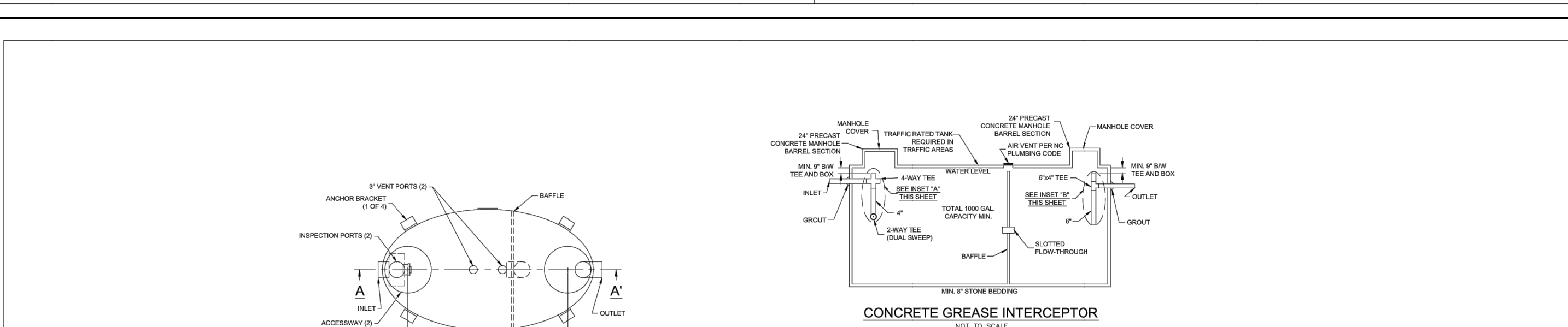
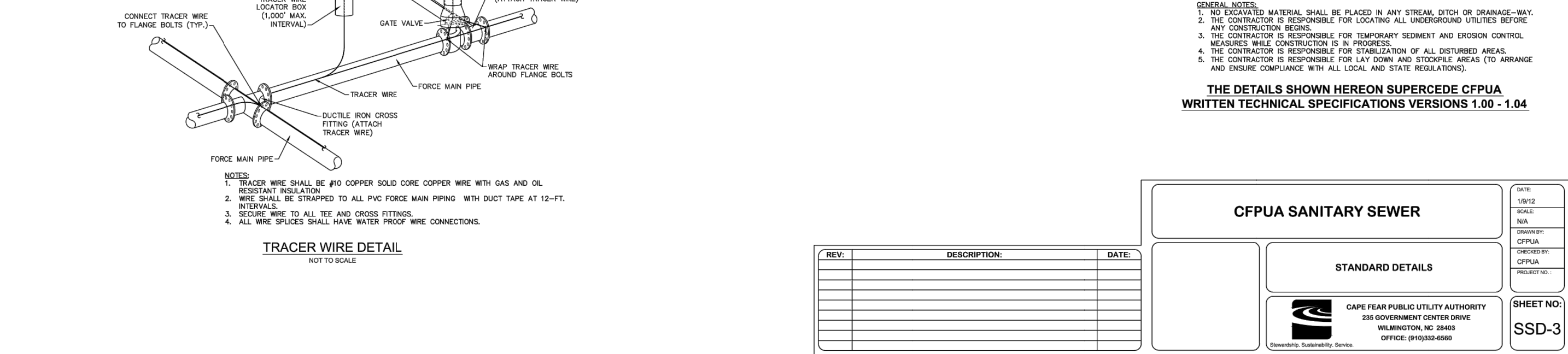
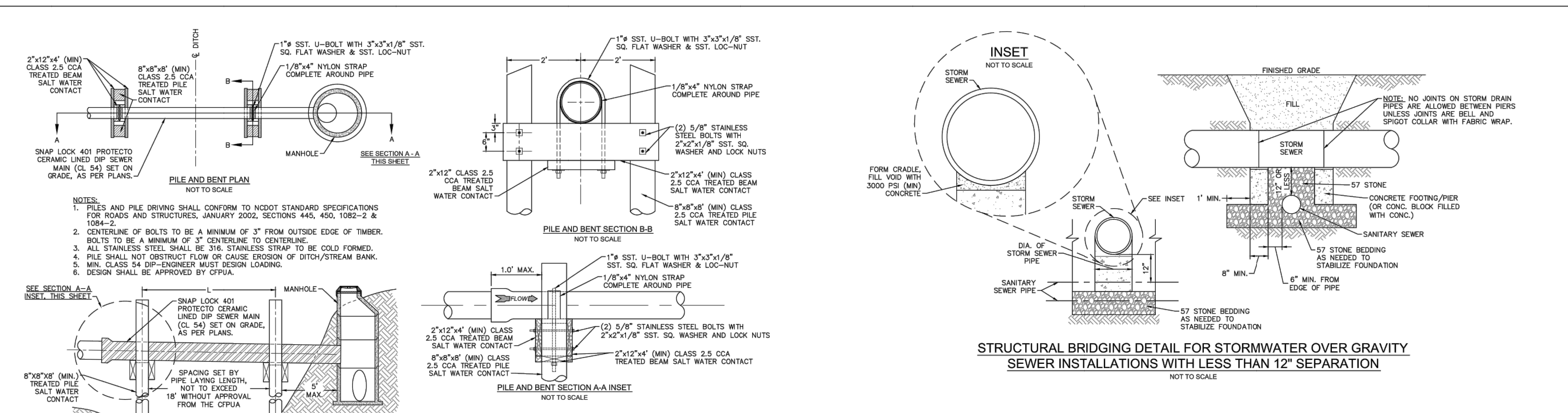
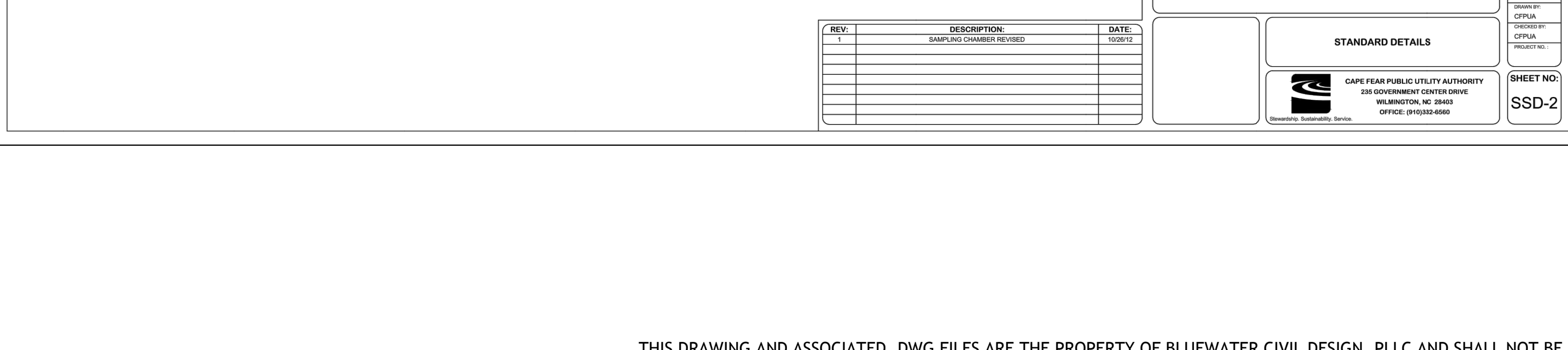
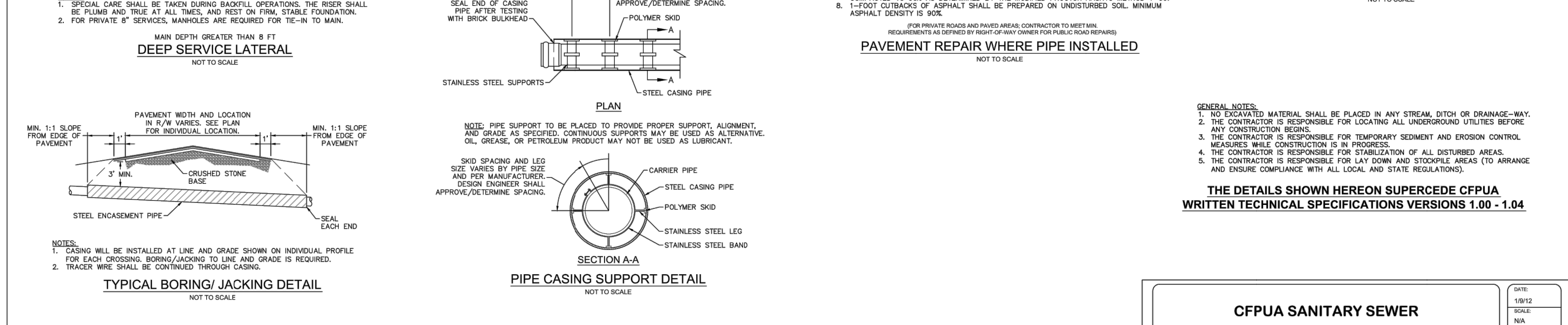
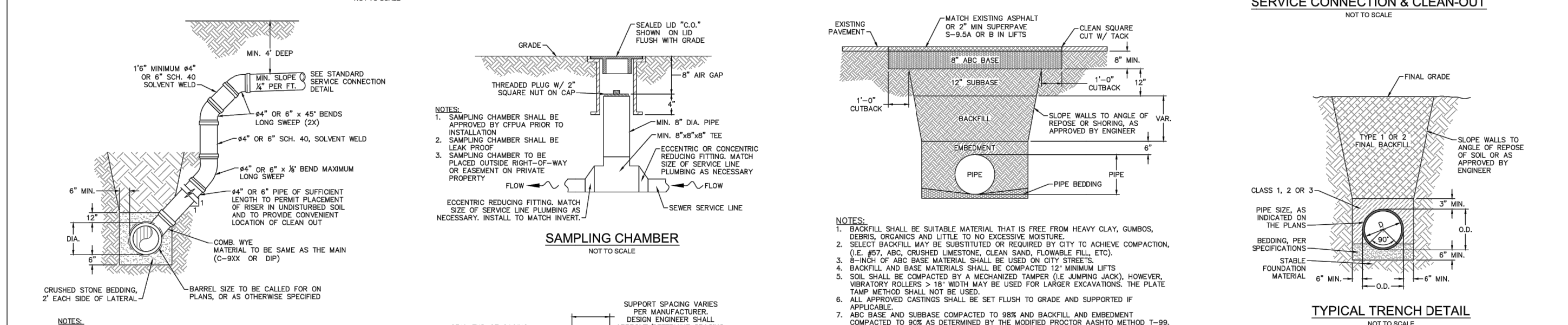
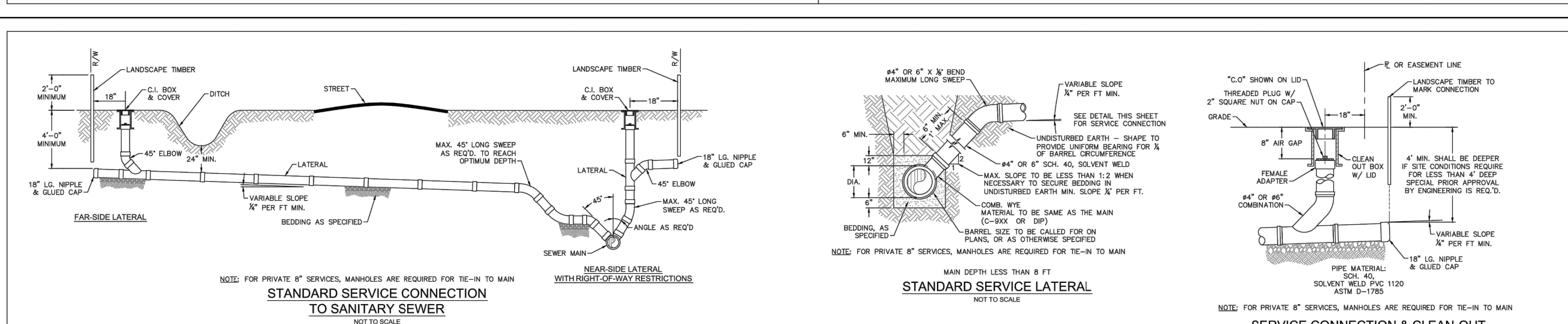
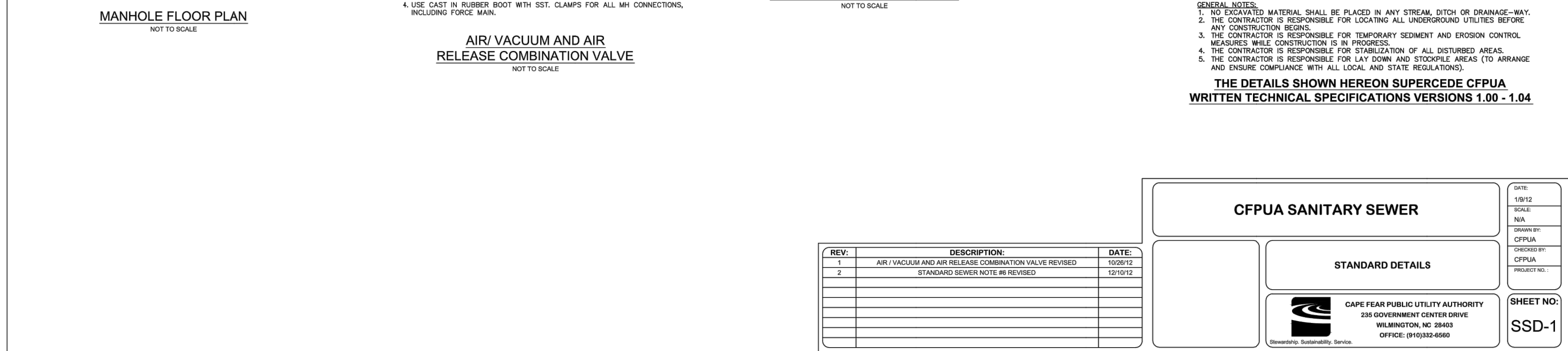
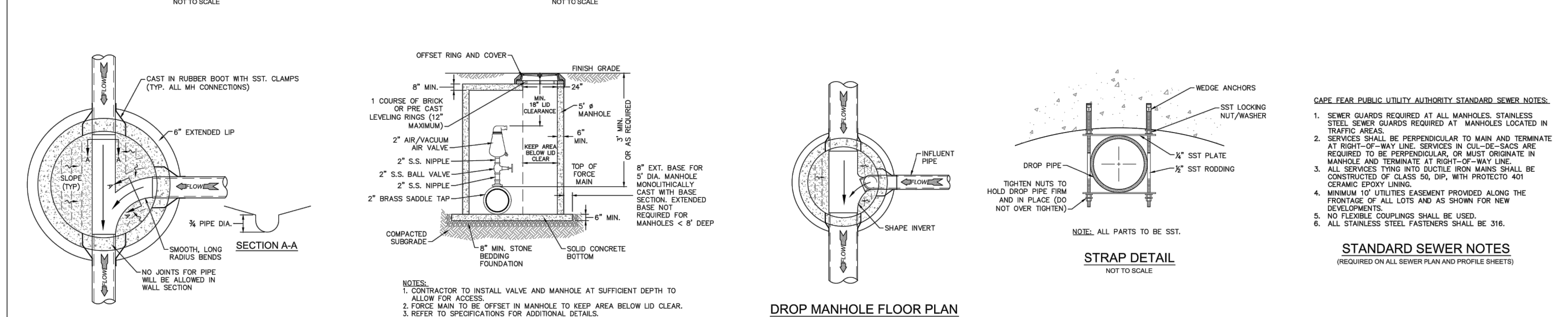
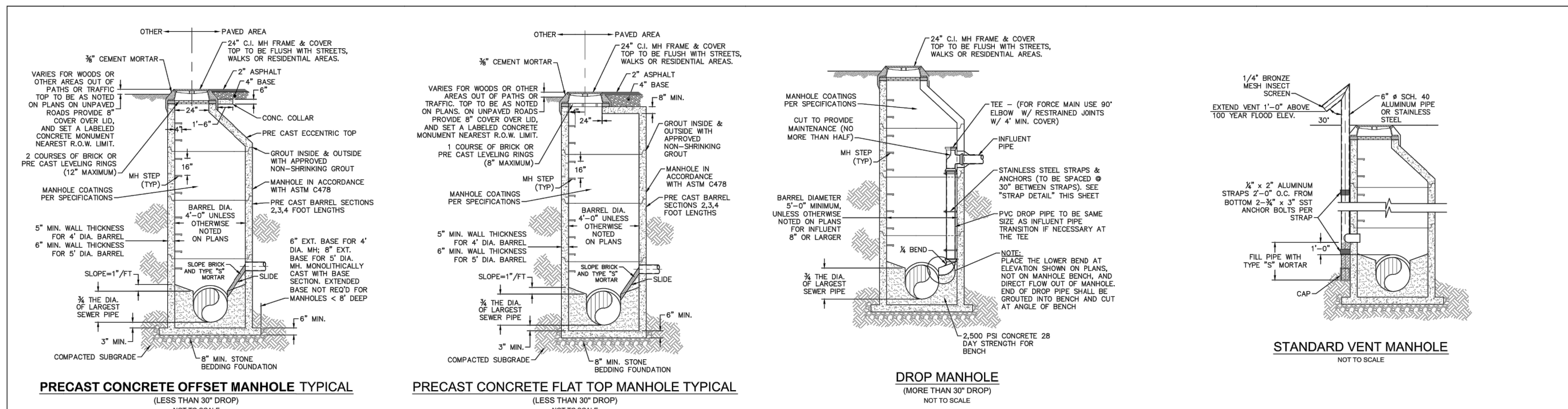

Project Number: 2014-090
 DWG Name: 2014-090 Details.dwg
 Drawing Scale: as noted
 Date of Project: 10-21-2014
 Engineer of Record:
 Jason Henderson, P.E.
 South Carolina PE# 22406
 Georgia PE# 020711
 North Carolina PE# 031306
 Alabama PE# 32054

bluewater
 civil design, PLLC
 bluewater civil design, PLLC
 19 Washington Park Suite 100 • Greenville, SC 29601
 www.bluewatercivil.com • info@bluewatercivil.com

Certificates of Authorization:
 SC 00412 - GA PE#005865
 NC 0668 - AL CA0656

BRAGG ROAD DEV. COMPANY, LLC
 Bragg Drive
 Wilmington, NC

Approved Construction Plan
 Name: _____
 Date: _____
 Planning: _____
 Traffic: _____
 Fire: _____

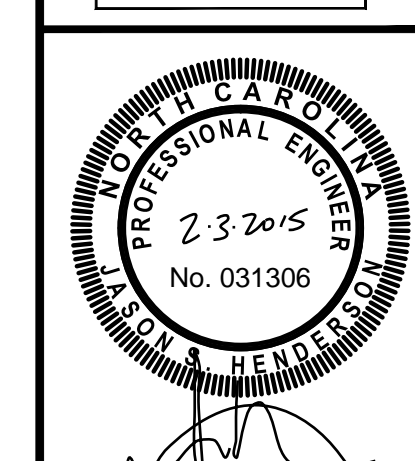

Bluewater Civil Design, PLLC
 NC-P-0668

PLAN REVISION	DATE	ISSUE COMMENT
A	2-3-2015	ISSUED FOR PERMITS

NOTES & DETAILS
 Date: _____ Permit # _____
 Signed: _____

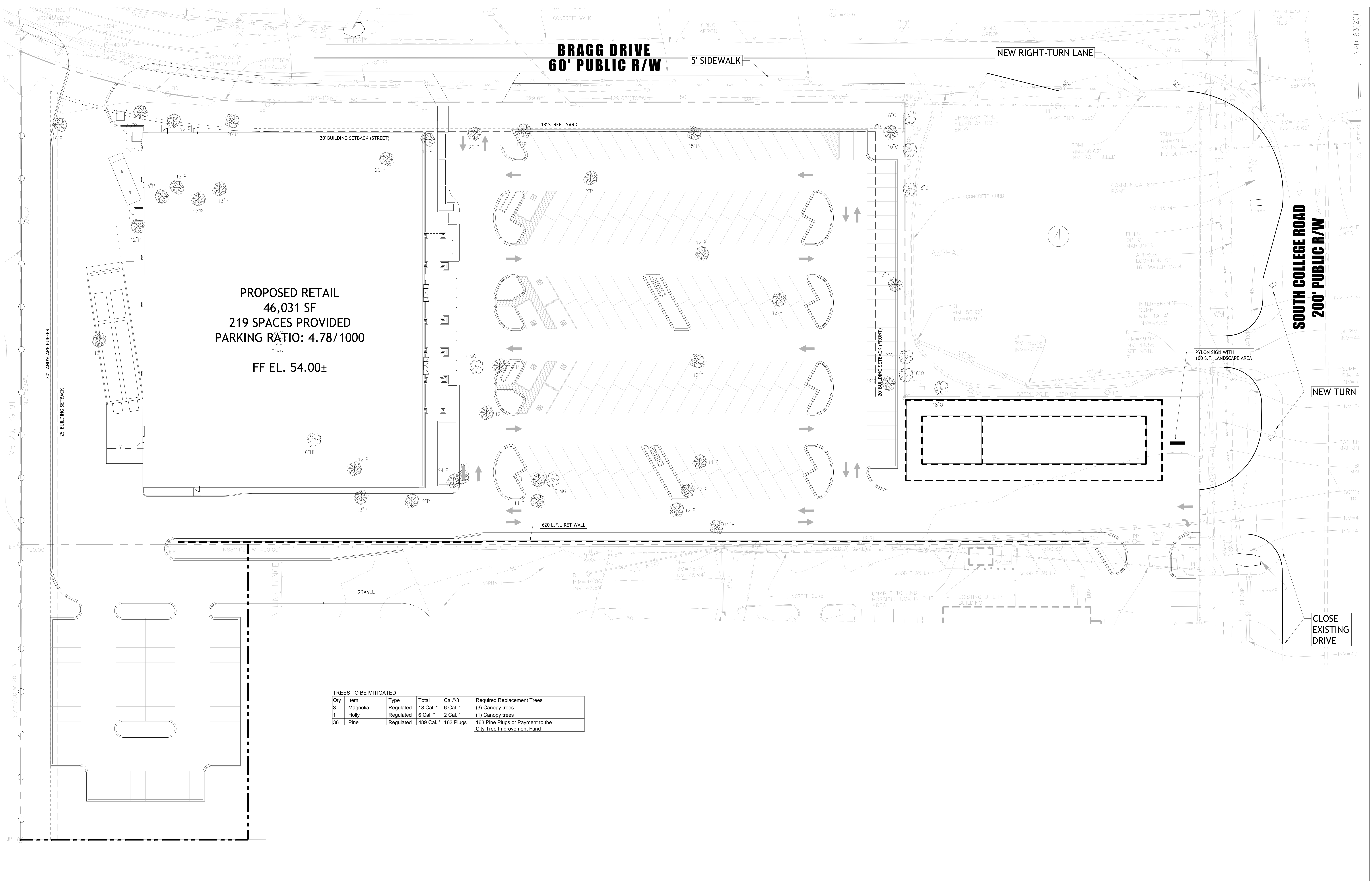

PROPOSED RETAIL
 46,031 SF
 219 SPACES PROVIDED
 PARKING RATIO: 4.78/1000
 FF EL. 54.00±

TREES TO BE MITIGATED

Qty	Item	Type	Total	Cal./3	Required Replacement Trees
3	Magnolia	Regulated	18 Cal.	6 Cal. *	(3) Canopy trees
1	Holly	Regulated	6 Cal.	2 Cal. *	(1) Canopy trees
36	Pine	Regulated	489 Cal.	163 Plugs	163 Pine Plugs or Payment to the City Tree Improvement Fund

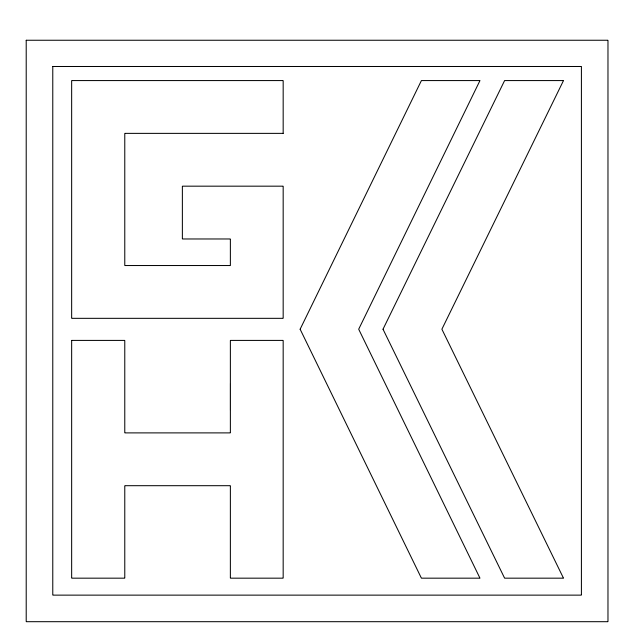

SCALE 1"=20'-0"
 0 10' 20' 40'

G.H.K. DEVELOPMENT
 3929 MAGAZINE STREET
 NEW ORLEANS, LA 70115

BRAGG ROAD DEVELOPMENT

COMPANY, LLC.

PROPOSED GROCERY STORE

WILMINGTON, NORTH CAROLINA

ISSUED DATE: 2-3-15
 REVISION DATE:
 TREE MITIGATION PLAN

LS-0

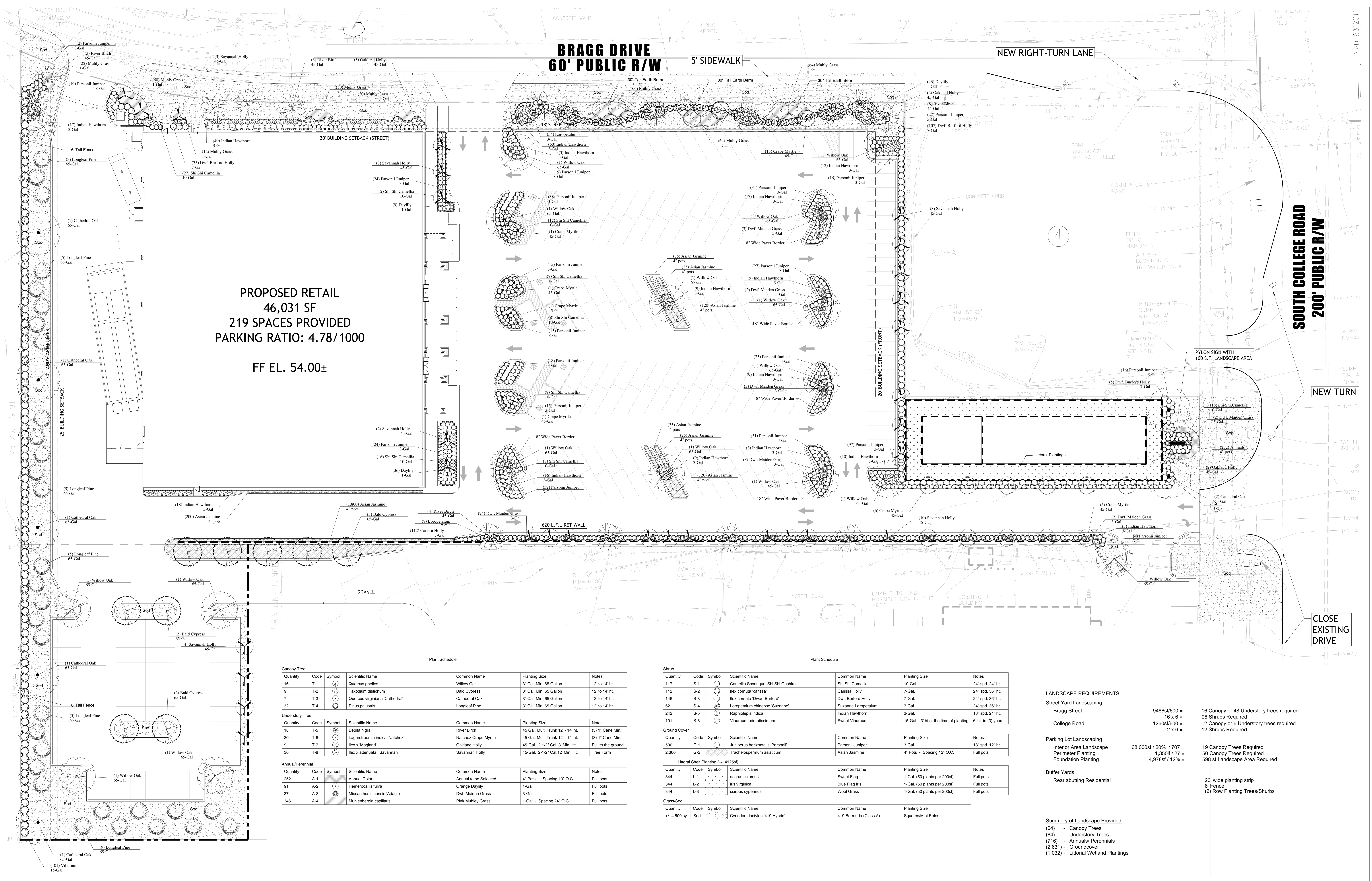

PROPOSED RETAIL
46,031 SF
219 SPACES PROVIDED
PARKING RATIO: 4.78/1000

FF EL. 54.00±

Plant Schedule

Quantity	Code	Symbol	Scientific Name	Common Name	Planting Size	Notes
16	T-1		Quercus phellos	Willow Oak	3" Cal. Min. 65 Gallon	12' to 14' ht.
9	T-2		Taxodium distichum	Bald Cypress	3" Cal. Min. 65 Gallon	12' to 14' ht.
7	T-3		Quercus virginiana 'Cathedral'	Cathedral Oak	3" Cal. Min. 65 Gallon	12' to 14' ht.
32	T-4		Pinus palustris	Longleaf Pine	3" Cal. Min. 65 Gallon	12' to 14' ht.
Understory Tree						
18	T-5		Betula nigra	River Birch	45 Gal. Multi Trunk 12' - 14' ht.	(3) 1" Canoe Min.
30	T-6		Ligustrum indica 'Natchez'	Natchez Crape Myrtle	45 Gal. Multi Trunk 12' - 14' ht.	(3) 1" Canoe Min.
9	T-7		Ilex x 'Majesty'	Oakland Holly	45 Gal. 2-1/2" Cal. 9" Min. Ht.	Full to the ground
30	T-8		Ilex x attenuata 'Savannah'	Savannah Holly	45-Gal. 2-1/2" Cal. 12" Min. Ht.	Tree Form
Annual/Perennial						
252	A-1		Annual Color	Annual to be Selected	4" Pots - Spacing 10" O.C.	Full pots
91	A-2		Hemerocallis fulva	Orange Daylily	1-Gal	Full pots
37	A-3		Miscanthus sinensis 'Adagio'	Dwf. Maiden Grass	3-Gal	Full pots
346	A-4		Muhlenbergia capillans	Pink Muhley Grass	1-Gal - Spacing 24" O.C.	Full pots

Plant Schedule

Quantity	Code	Symbol	Scientific Name	Common Name	Planting Size	Notes
117	S-1		Camellia sasangua 'Shi Shi Gashira'	Shi Shi Camellia	10-Gal.	24" spd. 24" ht.
112	S-2		Ilex cornuta 'carissa'	Carissa Holly	7-Gal.	24" spd. 36" ht.
146	S-3		Ilex cornuta 'Dwarf Burford'	Dwf. Burford Holly	7-Gal.	24" spd. 36" ht.
62	S-4		Liriodendron chinense 'Suzanne'	Suzanne Loropetalum	7-Gal.	24" spd. 36" ht.
242	S-5		Rapirolepis indica	Indian Hawthorn	3-Gal.	18" spd. 24" ht.
101	S-6		Viburnum odoratissimum	Sweet Viburnum	15-Gal. 3' ht at the time of planting	6' ht. in (3) years
Ground Cover						
500	G-1		Juniperus horizontalis 'Parsonii'	Parsonii Juniper	3-Gal	18" spd. 12" ht.
2,360	G-2		Trachelospermum asiaticum	Asian Jasmine	4" Pots - Spacing 12" O.C.	Full pots
Littoral Shelf Planting (+/- 4125sf)						
344	L-1		Asarum canadense	Sweet Flag	1-Gal. (50 plants per 200sf)	Full pots
344	L-2		Iris virginica	Blue Flag Iris	1-Gal. (50 plants per 200sf)	Full pots
344	L-3		Scirpus cyperinus	Wool Grass	1-Gal. (50 plants per 200sf)	Full pots
Grass/Sod						
Quantity	Code	Symbol	Scientific Name	Common Name	Planting Size	Notes
+/- 4,500 sq	Sod		Cynodon dactylon '419 Hybrid'	419 Bermuda (Class A)	Squares/Mini Roles	

LANDSCAPE REQUIREMENTS

Area	Requirements	Notes
Street Yard Landscaping	9486sf/600 = 16 x 6 = 1260sf/600 = 2 x 6 =	16 Canopy or 48 Understory trees required 96 Shrubs Required 2 Canopy or 6 Understory trees required 12 Shrubs Required
Parking Lot Landscaping	68,000sf / 20% / 707 = 1,350sf / 27 = 4,978sf / 12% =	19 Canopy Trees Required 50 Canopy Trees Required 598 of Landscape Area Required
Buffer Yards		20' wide planting strip 6' Fence (2) Row Planting Trees/Shrubs

Summary of Landscape Provided
 (64) - Canopy Trees
 (84) - Understory Trees
 (715) - Annuals/Perennials
 (2,631) - Groundcover
 (1,032) - Littoral Wetland Plantings

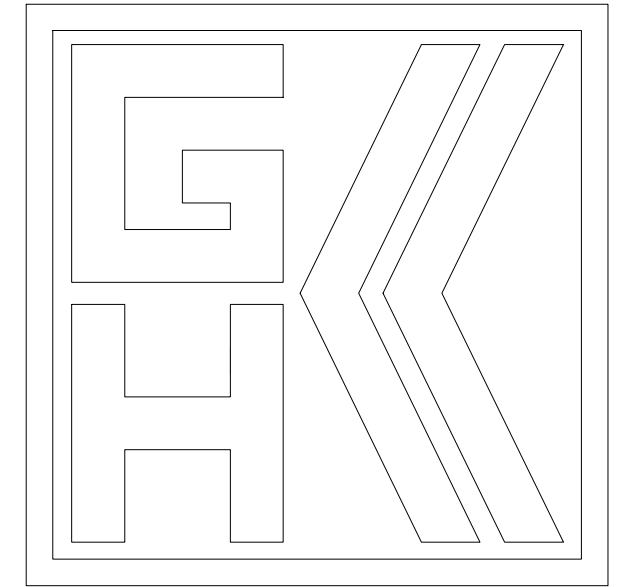

0 10' 20' 40'
 SCALE 1"=20'-0"

G.H.K. DEVELOPMENT
 3929 MAGAZINE STREET
 NEW ORLEANS, LA 70115

BRAGG ROAD DEVELOPMENT

COMPANY, LLC.

PROPOSED GROCERY STORE

WILMINGTON, NORTH CAROLINA

ISSUED DATE: 2-3-15
 REVISION DATE:
LANDSCAPE PLAN

LS-1

SECTION 02900 – LANDSCAPING

1.1 GENERAL

- A. Submittals: In addition to product certificates, submit the following:
 1. Certification of grass seed from seed vendor for each seed mixture.
 2. Planting schedule indicating anticipated dates and locations for each type of planting.
- B. Quality Assurance: Provide trees, shrubs, ground covers, and plants of quality, size, genus, species, and variety indicated, complying with applicable requirements of ANSI Z60.1 "American Standard for Nursery Stock."
- C. Special Warranty: Warrant trees, shrubs and ground covers for a period of one year after date of Substantial Completion, against defects including death and unsatisfactory growth, except for defects resulting from lack of adequate maintenance, neglect, or abuse by Owner, abnormal weather conditions unusual for warranty period, or incidents which are beyond Contractor's control.
 1. Remove and replace unhealthy and dead trees and shrubs within the warranty period.
- D. Maintain and establish lawns by watering, fertilizing, weeding, mowing, trimming, replanting, and other operations to produce a uniformly smooth lawn for not less than the following:
 1. Seeded Lawns: 60 days after date of Substantial Completion.
 2. Sodded Lawns: 30 days after date of Substantial Completion.

1.2 PRODUCTS

- A. Trees and Shrubs: Well-shaped, fully branched, healthy, vigorous nursery-grown stock of sizes and grades indicated, free of disease, insects, eggs, larvae, and defects, conforming to ANSI Z60.1.
 1. Provide balled and burlapped trees and shrubs.
 2. Provide container grown trees and shrubs.
- B. Ground Covers and Plants: Established and well rooted in removable containers or integral peat pots and with not less than the minimum number and length of runners required by ANSI Z60.1 for the pot size indicated.
- C. Grass Seed: Fresh, clean, dry, new-crop seed complying with the Association of Official Seed Analysts' "Rules for Testing Seeds" for purity and germination tolerances.
 1. Seed Mixture: Provide seed of grass species and varieties, proportions by weight, and minimum percentages of purity, germination, and maximum percentage of weed seed as indicated.
- D. Sod: Certified turfgrass sod complying with ASPA specifications for machine-cut thickness, size, strength, moisture content, and mowed height, and free of weeds and undesirable native grasses. Provide viable sod of uniform density, color, and texture, strongly rooted, and capable of vigorous growth and development when planted.
 1. Species: Provide sod of grass species and varieties, proportions by weight, and minimum percentages of purity, germination, and maximum percentage of weed seed as indicated.
- E. Topsoil: ASTM D 5268, pH range of 5.5 to 7, 4 percent organic material minimum, free of stones 1 inch (25 mm) or larger in any dimension, and other extraneous materials harmful to plant growth.
 1. Topsoil Source: Amend existing surface soil to produce topsoil. Supplement with imported topsoil when required.
 2. Imported topsoil: Equal parts of sharp sand, peat moss and composted bark.
- F. Lime: ASTM C 602, Class T, agricultural limestone.
- G. Peat Humus: Finely divided or granular texture, with a pH range of 6 to 7.5, composed of partially decomposed moss peat (other than sphagnum), peat humus, or reed-sedge peat.
- H. Sawdust or Ground-Bark Humus: Decomposed, nitrogen-treated, of uniform texture, free of chips, stones, sticks, soil, or toxic materials.
- I. Bonemeal: Commercial, raw, finely ground; minimum of 4 percent nitrogen and 20 percent phosphoric acid.
- J. Superphosphate: Commercial, phosphate mixture, soluble; minimum of 20 percent available phosphoric acid.
- K. Commercial Fertilizer: Commercial-grade complete fertilizer of neutral character, consisting of fast- and slow-release nitrogen, 50 percent derived from natural organic sources of urea-form, phosphorous, and potassium in the following composition:
 1. Composition: 1 lb per 1000 sq. ft. (0.5 kg per 100 sq. m) of actual nitrogen, 4 percent phosphorous, and 2 percent potassium, by weight.
- L. Slow-Release Fertilizer: Granular fertilizer consisting of 50 percent water-insoluble nitrogen, phosphorus, and potassium in the following composition:
 1. Composition: 5 percent nitrogen, 10 percent phosphorous, and 5 percent potassium, by weight.
- M. Organic Mulch: Organic mulch, free from deleterious materials and suitable as a top dressing, consisting of ground or shredded bark, wood or bark chips, salt hay or threshed straw, or shredded hardwood.
- N. Peat Mulch: Provide peat moss in natural, shredded, or granulated form, of fine texture, with a pH range of 4 to 6.
- O. Mineral Mulch: Hard, durable riverbed gravel or crushed stone, washed free of loam, sand, clay, and other foreign substances.
 1. Size Range: 1-1/2 inches (38 mm) maximum, 3/4 inch (19 mm) minimum.
- P. Steel Edging: ASTM A 569 (ASTM A 569M), rolled edge, standard painted steel edging and accessories, fabricated in sections with loops stamped from or welded to face of sections approximately 30 inches (760 mm) apart to receive stakes.
 1. Edging Size: 3/16 inch (4.8 mm) wide by 4 inches (102 mm) deep.

1.3 EXECUTION

- A. Planting Soil Preparation: Before mixing, clean topsoil of roots, plants, sods, stones, clay lumps, and other extraneous materials harmful to plant growth. Mix soil amendments and fertilizers with topsoil at rates indicated.
- B. Lawn Planting Preparation: Loosen subgrade to a minimum depth of 4 inches (100 mm). Remove stones larger than 1-1/2 inches (38 mm) in any dimension and sticks, roots, rubbish, and other extraneous materials.
 1. Spread planting soil mixture to depth required to meet thickness, grades, and elevations shown, after light rolling and natural settlement. Do not spread if planting soil or subgrade is frozen.
 2. Place approximately 1/2 the thickness of planting soil mixture required. Work into top of loosened subgrade to create a transition layer and then place remainder of planting soil mixture.
- C. Lawn Planting Preparation: Where lawns are to be planted in areas unaltered or undisturbed by excavating, grading, or surface soil stripping operations, remove and dispose of existing grass, vegetation, and turf.
 1. Till surface soil to a depth of at least 6 inches (150 mm). Apply soil amendments and initial fertilizers and mix thoroughly into top 4 inches (100 mm) of soil. Trim high areas and fill in depressions. Till soil to a homogenous mixture of fine texture.
- D. Grade lawn areas to a smooth, even surface with loose, uniformly fine texture. Remove trash, debris, stones larger than 1-1/2 inches (38 mm) in any dimension, and other objects that may interfere with planting or maintenance operations.
- E. Moisten prepared lawn areas before planting when soil is dry and allow surface to dry before planting.
- F. Ground Cover and Plant Bed Preparation: Loosen subgrade of planting bed areas to a minimum depth of 6 inches (150 mm). Remove stones larger than 1-1/2 inches (38 mm) in any dimension and sticks, roots, rubbish, and other extraneous materials.
 1. Spread planting soil mixture to depth required to meet thickness, grades, and elevations shown, after light rolling and natural settlement. Place approximately 1/2 the thickness of planting soil mixture required. Work into top of loosened subgrade to create a transition layer and then place remainder of planting soil mixture.
- G. Ground Cover and Plant Bed Preparation: Till soil in beds to a minimum depth of 8 inches (200 mm) and mix with specified soil amendments and fertilizers.
- H. Excavation for Trees and Shrubs: Excavate pits with vertical sides and with bottom of excavation slightly raised at center to assist drainage. Excavate approximately 1-1/2 times as wide as ball diameter and deep enough to allow placing of root ball on a setting layer of planting soil. Loosen hard subsoil in bottom of excavation.
- I. Planting Trees and Shrubs: Set stock plumb and in center of pit or trench with top of ball raised above adjacent finish grades.
 1. Place a setting layer of compacted planting soil.
 2. Remove burlap and wire baskets from tops of balls and partially from sides, but do not remove from under balls. Do not use planting stock if ball is cracked or broken before or during planting operation.
 3. Place backfill around ball in layers, tamping to settle backfill and eliminate voids and air pockets.
 4. Dish and tamp top of backfill to form a 3-inch- (75-mm-) high mound around the rim of the pit. Do not cover top of root ball with backfill.
- J. Tree and Shrub Pruning: Prune, thin, and shape trees and shrubs according to standard horticultural practice. Prune trees to retain required height and spread. Do not cut tree leaders; remove only injured or dead branches from flowering trees. Prune shrubs to retain natural character. Shrub sizes indicated are size after pruning.
- K. Planting Ground Cover and Plants: Space 24 inches (600 mm) apart, unless otherwise indicated. Dig holes large enough to allow spreading of roots, and backfill with planting soil. Work soil around roots to eliminate air pockets and leave a slight saucer indentation around plants to hold water. Water thoroughly after planting, taking care not to cover plant crowns with wet soil.
- L. Mulching: Completely cover area to be mulched. Apply mulch and finish level with adjacent finish grades. Do not place mulch against trunks or stems.
 1. Mulch Type and Thickness: Cut pine straw, 3 inches (75 mm) thick as indicated on drawings.
- M. Seeding Lawns: Sow seed with a spreader or a seeding machine. Do not broadcast or drop seed when wind velocity exceeds 5 mph (8 km/h). Evenly distribute seed by sowing equal quantities in 2 directions at right angles to each other. Rake seed lightly into top 1/8 inch (3 mm) of topsoil, roll lightly, and water with fine spray.
 1. Seeding Rate: 3 to 4 lb per 1000 sq. ft. (1.5 to 2 kg per 100 sq. m).
 2. Protect seeded areas with slopes less than 1:6 against erosion by spreading straw mulch after completion of seeding operations and anchor by crimping into topsoil. Spread uniformly at a minimum rate of 2 tons per acre (45 kg per 100 sq. m).
- N. Sodding Lawns: Lay sod to form a solid mass with tightly fitted joints within 24 hours of stripping. Butt ends and sides of sod; do not stretch or overlap. Stagger sod strips or pads to offset joints in adjacent courses. Avoid damage to subgrade or sod during installation. Tamp and roll lightly to ensure contact with subgrade, eliminate air pockets, and form a smooth surface. Work sifted soil or fine sand into minor cracks between pieces of sod; remove excess to avoid smothering sod and adjacent grass.
 1. Anchor sod on slopes exceeding 1:6 with wood pegs spaced as recommended by sod manufacturer.
 2. Saturate sod with fine water spray within 2 hours of planting. During first week, water daily or more frequently as necessary to maintain moist soil to a minimum depth of 1-1/2 inches (38 mm) below the sod.
- O. Edgings: Install edgings where indicated and anchor with stakes driven below top elevation of edging according to manufacturer's recommendations.
- P. Disposal: Remove surplus soil and waste material, including excess subsoil, unsuitable soil, trash, and debris, and legally dispose of it off the Owner's property.

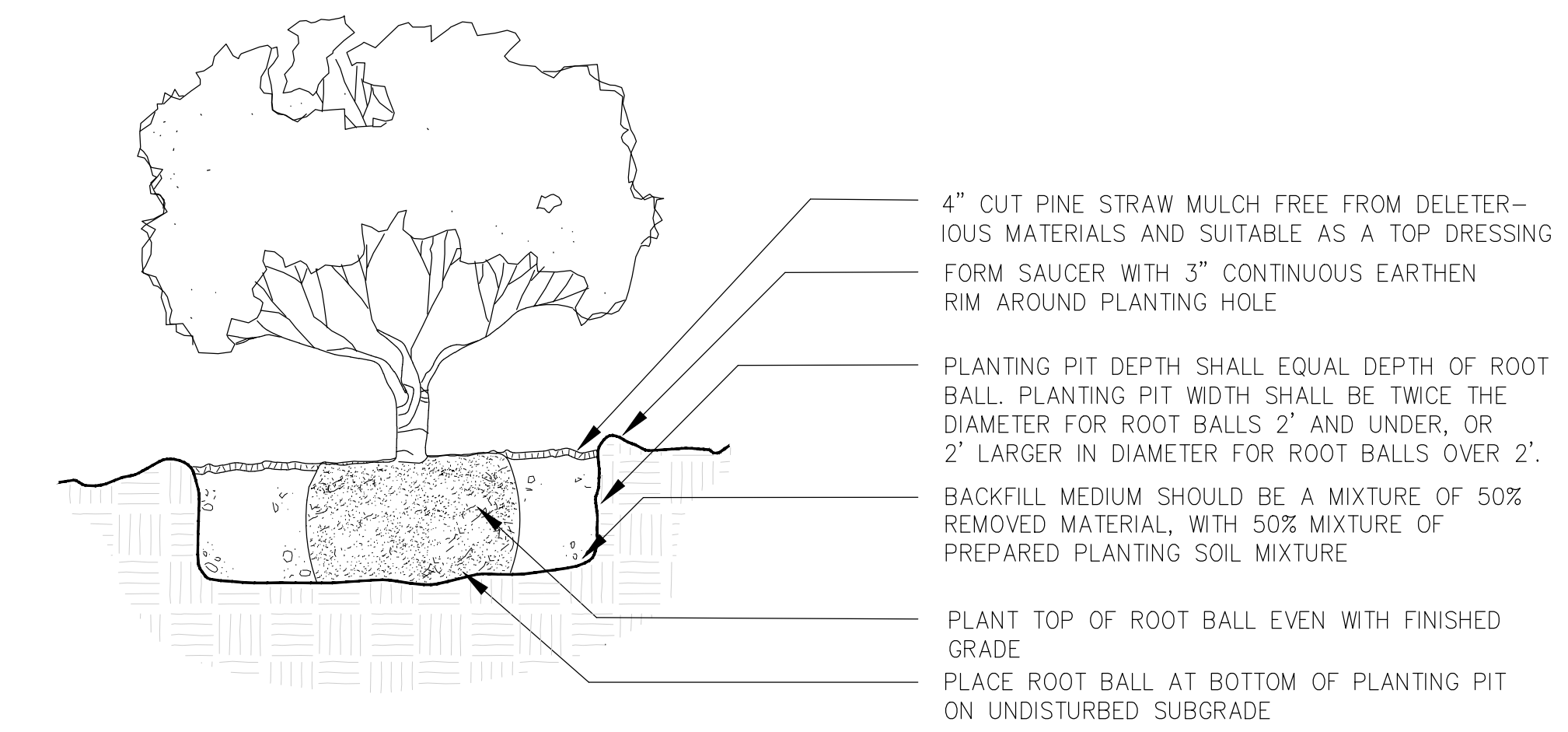

1 SHRUB DETAIL
LS-2 NTS

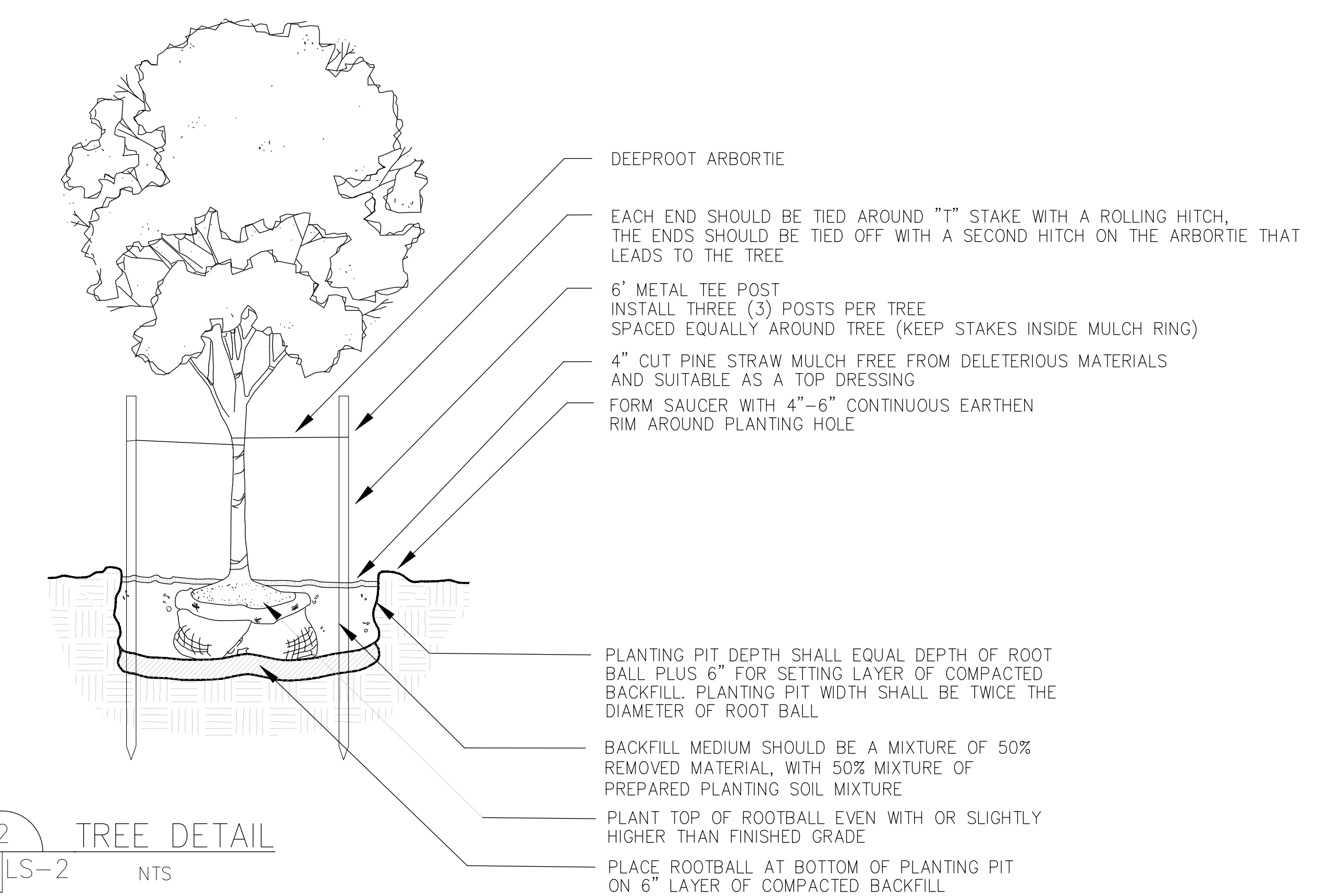

2 TREE DETAIL
LS-2 NTS

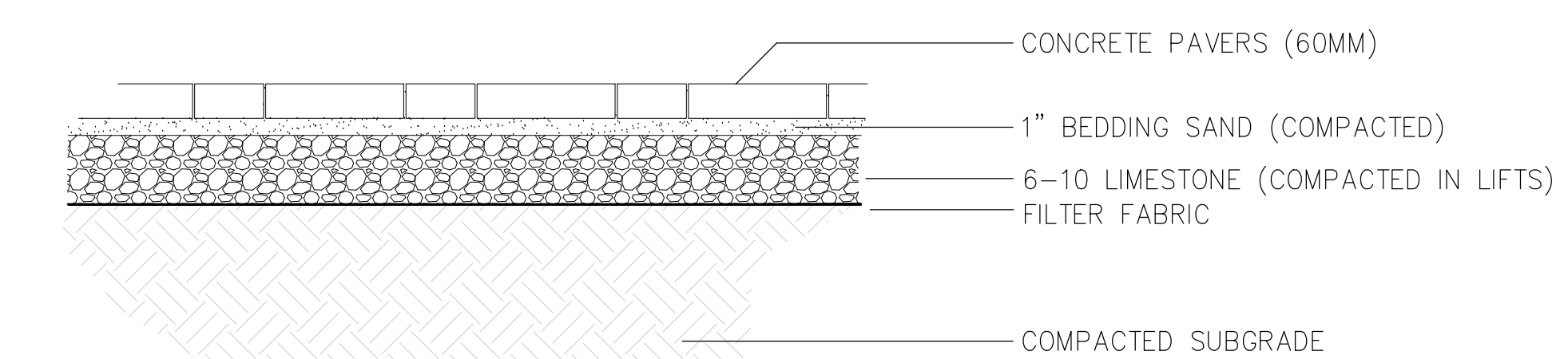

CONCRETE PAVERS (FIELD STONE):
MANUFACTURER: BELGARD
PRODUCT: DUBLIN COBBLE
PATTERN: 3 PIECE PATTERN
COLOR: DANVILLE BEIGE

JOINT SAND:
MANUFACTURER: TECHNISEAL
HP2 POLYMERIC JOINT SAND
COLOR: BUFF

3 CONCRETE PAVER DETAIL
LS-2 NTS

END OF SECTION 02900

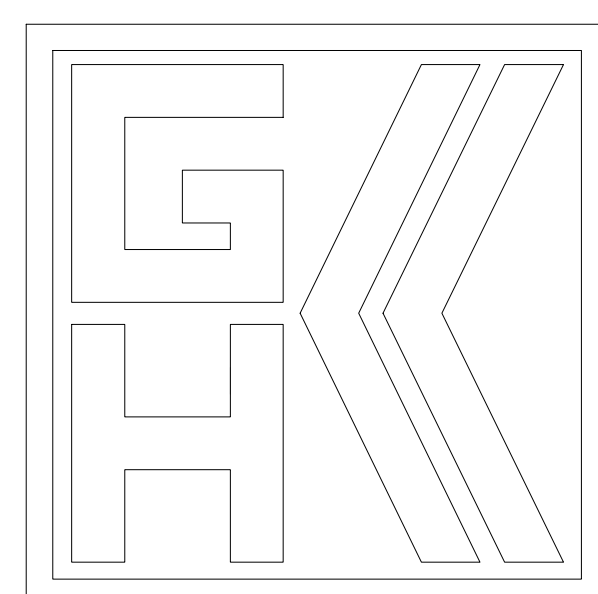

0 10' 20' 40'
SCALE 1"=20'-0"

G.H.K. DEVELOPMENT
3929 MAGAZINE STREET
NEW ORLEANS, LA 70115

BRAGG ROAD DEVELOPMENT COMPANY, LLC. PROPOSED GROCERY STORE WILMINGTON, NORTH CAROLINA

ISSUED DATE: 2-3-15
REVISION DATE: _____
LANDSCAPE DETAILS _____

LS-2